

AUSTREX
FOR YOUR BEST PERFORMANCE

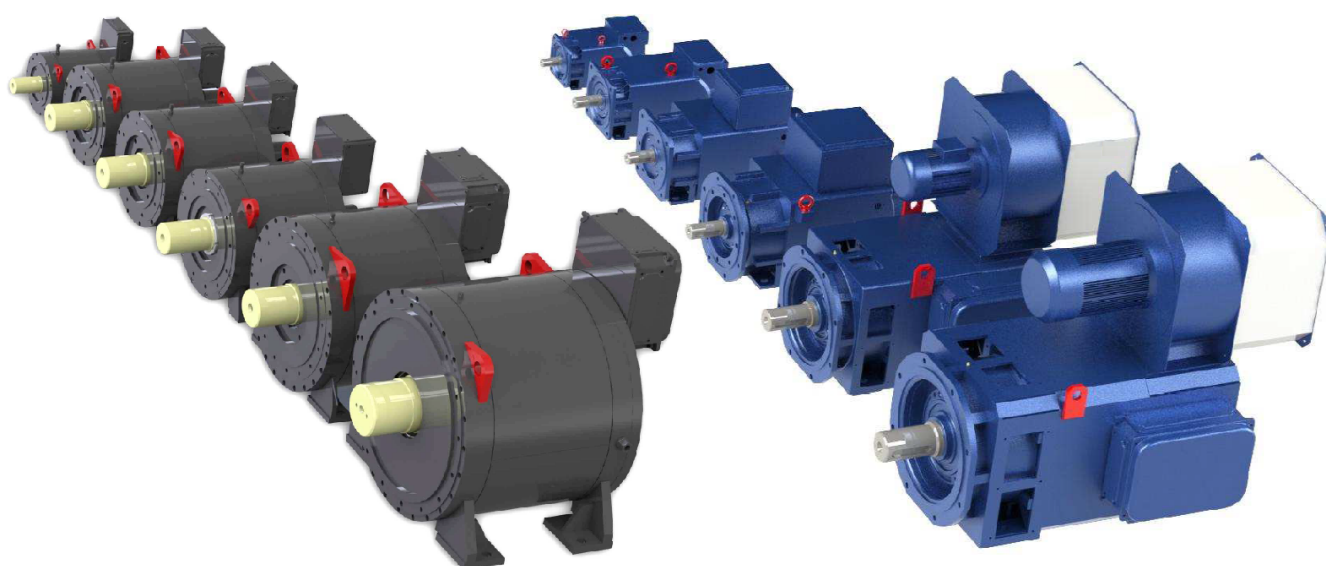

GENERAL CATALOGUE MOTORS

ASYNCHRON - SYNCHRON - TORQUE



COMER

Emotion in Motion

May 2017

MAIN INDEX

OUR HISTORY	4
TECHNICAL DEPARTMENT AND PRODUCTION	5
DOCUMENTATION	6

ASYNCHRONOUS MOTORS

POWERTECH DRIVE AX SERIES	7
DRIVE AX 63C	8
DRIVE AX 63CS	10
DRIVE AX 80C	12
DRIVE AX 80CS	15
DRIVE AX 100K	18
DRIVE AX 132K	25
DRIVE AX 160L	31
DRIVE AX 200L	37
DRIVE AX 250K/KC	43
DRIVE AX 250K/KC (AXIAL FAN VERSION)	49
DRIVE AX 315L	55
POWERTECH TETRAVEC SERIES	58
TETRAVEC 100K	59
TETRAVEC 132K	66
TETRAVEC 160L	72
TETRAVEC 200L	78
TETRAVEC 250K/KC	84
TETRAVEC 315L	90
POWERTECH FLUID AX SERIES	93
FLUID AX 100C	94
FLUID AX 132C	96
FLUID AX 160C	98
FLUID AX 200C	100
FLUID AX 250K/KC	102
FLUID AX 315C	104
POWERTECH HIGH SPEED SERIES	108
HIGH SPEED SERIES OVERVIEW	109
S4 TETRAVEC 200L, S2 TETRAVEC 200L	110
S4 TETRAVEC 250K, S2 TETRAVEC 250K	111
S4 TETRAVEC 315L, S2 TETRAVEC 315L	112
HS2 TETRAVEC 225, HS2 TETRAVEC 280, HS2 TETRAVEC 355	113

MAIN INDEX

PERMANENT MAGNETS SYNCHRONOUS MOTORS

POWERTECH ST SERIES	114
POWERTECH ST SERIES OVERVIEW	115
ST22 FLUID 13	116
ST22 FLUID 16	117
ST30 FLUID 20	118
ST30 FLUID 25	119
ST44 FLUID 31	120
ST44 FLUID 40	121
POWERTECH SY SERIES	122
SY12 DRIVE 160	123
SY16 DRIVE 200	125
SY16 DRIVE 250	127
SY16 DRIVE 315	129
SY12 TETRAVEC 160	131
SY16 TETRAVEC 200	133
SY16 TETRAVEC 250	135
SY16 TETRAVEC 315	137
SY12 FLUID 160	139
SY16 FLUID 200	141
SY16 FLUID 250	143
SY16 FLUID 315	145
SY12 FLUID 400 & SY24 FLUID 400	147
POWERTECH SY4 & SY6 SERIES (SUPER PREMIUM EFFICIENCY IE4)	150
SY4 DRIVE 132K	151
SY4 DRIVE 160L	153
SY6 DRIVE 200L	155
SY6 DRIVE 250K	157
SY6 DRIVE 315L	159
SY4 TETRAVEC 132K	161
SY4 TETRAVEC 160L	163
SY6 TETRAVEC 200L	165
SY6 TETRAVEC 250K	167
SY6 TETRAVEC 315L	169
SY4 FLUID 132	171
SY4 FLUID 160	173
SY6 FLUID 200	175
SY6 FLUID 250	177
SY6 FLUID 315	179
OTHER AC PRODUCTION	181

OUR HISTORY



COMER is an industrial project set in motion at the end of the 1950s thanks to the creativity and determination of its three founders. Initially we built standard asynchronous motors, while over the years production has been evolving into the more specialized sector of direct current motors, becoming the core business till the mid-1990s.

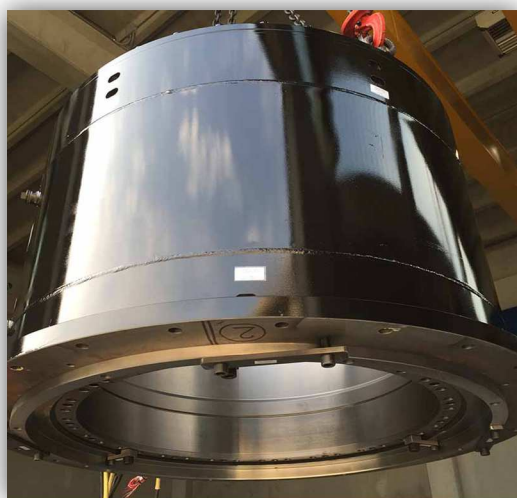

POWERTECH

With the advent of modern frequency converters, we've begun a new design season that culminated in the **POWERTECH** series of high performance asynchronous motors. Starting in 2005, our R&D division has investigated and designed the first series of Permanent Magnet Torque motors with a very high number of poles - and synchronous generators to be used in the wind power sector. Later in 2010 was born the High Speed motors series, specifically conceived for rig test application in the automotive sector.

HERITAGE & INNOVATION

Today, at 60 years since foundation, we are an established Italian leader in the design and production of special asynchronous motors and permanent magnet synchronous motors and generators.



ASYNCHRONOUS MOTORS

COMER's high performance asynchronous motors are built according to the highest quality Standards and can be adopted in a wide range of applications. Our motors are provided with squirrel cage rotors with aluminum slots (or copper in the biggest frames). Available in both air and liquid cooling versions.

SYNCHRONOUS MOTORS

COMER's high performance synchronous motors line is the result of a persistent research in the electromagnetic sector and employment of the most advanced materials. The rotor is provided with permanent rare-earth magnets with outcome of compact and light motors, having extremely high torque and power values. Available in both air and liquid cooling versions.



TECHNICAL DEPARTMENT AND PRODUCTION

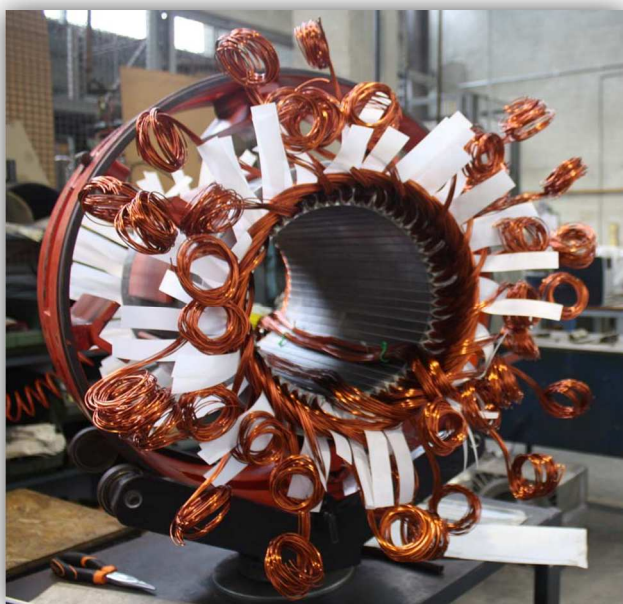

We boast a modern and efficient technical department equipped with the latest software for engineering and designing. The complete in-house design allows us to meet with customers' specific requirements, even tailor-made solutions.



ISO 9001:2008

The whole production process is controlled inside the factory and certified by ISO 9000 Quality System since 1995, now ISO 9001:2008. At the end of manufacturing process, the motors and generators are tested on computerized test benches, equipped with inverters and energy recovery AFE device: in this way we protect the environment from CO₂ emissions and re-use the excess energy into the Factory needs.

PHOTOVOLTAIC

To contribute to a better quality of life on our planet, we have installed a 140 kWp photovoltaic park on the roof of our Factory, able to supply about 50% of energy necessary to the Company.



TECHNICAL DOCUMENTATION

Each motor is supplied with name plate, instruction manual, test report, certificate of compliance, bearings operating range and lubrication instructions and all terminal board diagrams. Optionally, motors are further provided with additional test reports, such as vibration, noise, flange report and equivalent circuit.

The collage displays various technical documents from COMER, including:

- Motor Specifications:** A table for Motor type TETRAVEC 250K3, showing parameters like speed (175 Hz, 3500 rpm), power (400 V, 633 A, 345 kW), and dimensions (2140 mm, 1540 mm).
- RAPPORTO VIBRAZIONI (VIBRATION REPORT):** Documents detailing vibration levels and limits for different motor series.
- TEST REPORTS:** Reports such as 'BOLLETTINO DI COLLAUDO (TEST REPORT)' and 'STATINO DI COLLAUDO FLANGIA (FLANGE REPORT)' with associated data tables and graphs.
- MANUALS:** Documents like 'MANUALE DI ISTRUZIONE MOTORI POWERTECH & TETRAM' and 'LUBRIFICAZIONE CUSCINETTI' (Bearing Lubrication).
- Technical Diagrams:** Schematics for equivalent circuits and terminal boards.
- Graphs:** Performance curves showing efficiency and power factor over a range of speeds.
- Product Images:** Close-up views of motor bearings and terminal boards.

ASYNCHRONOUS MOTORS

RELIABILITY
HIGH EFFICIENCY
LOW NOISE LEVEL
GOOD TORQUE/WEIGHT RATIO
WIDE CONSTANT POWER RANGE
SUITABLE FOR VECTOR DRIVES
WIDE RANGE OF CUSTOMIZATION AND
OPTIONS

TYPICAL APPLICATIONS

MACHINE TOOLS
COMPRESSORS
TRACTION CONTROL
FOOD BOXES EXTRUDERS
WINDERS AND UNWINDERS
PAPER AND CARDBOARD PRODUCTION
MACHINERY
PROCESSING AND CUTTING METAL PLATES
METAL WIRE PROCESSING MACHINERY
PLASTIC AND RUBBER EXTRUDERS
LIFTING AND HANDLING SYSTEMS
PACKAGING MACHINERY
PRINTING MACHINERY
TEXTILE MACHINERY

IP PROTECTION **IP54**
COOLING METHOD **IC416**

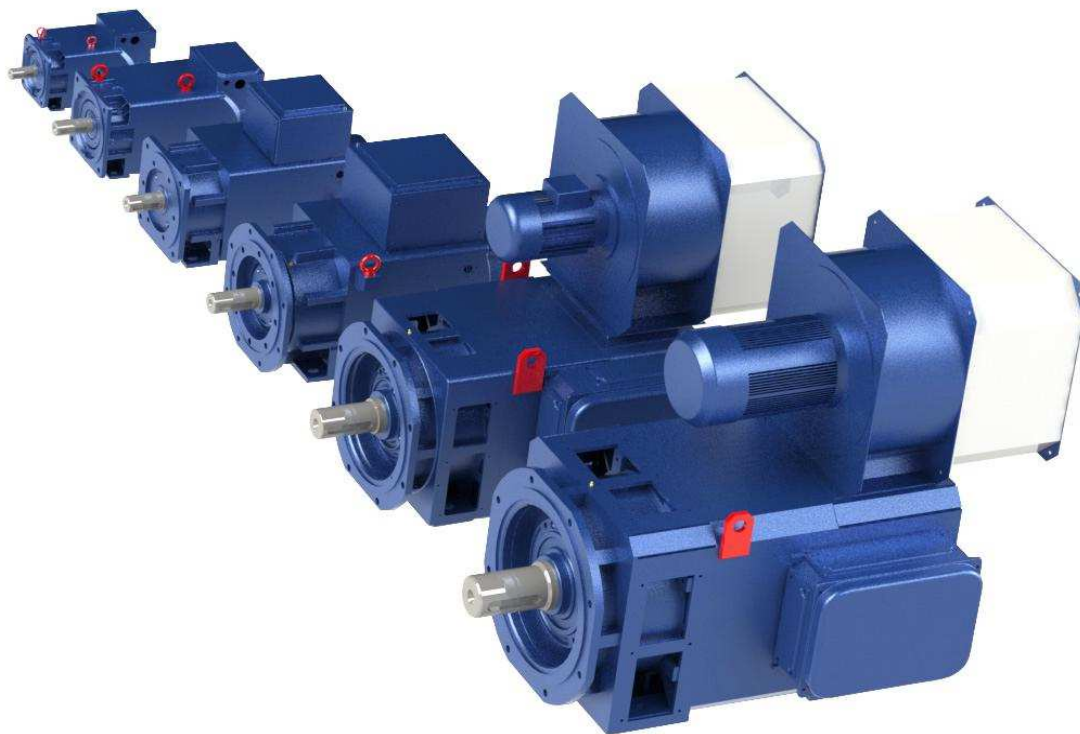

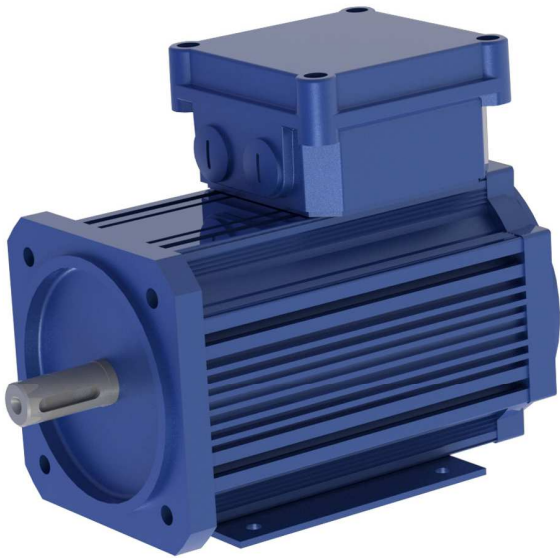

IP PROTECTION	IP54
THERMAL PROTECTION TYPE	KLIXON (PT100, PTC on request)
BALANCING, VIBRATION GRADE (EN 60034-14 / VDE 0530 part 14)	A (B on request)
INSULATION CLASS	F
COOLING METHOD	IC410 (IC416A on request)
STANDARD FAN (IC416A only)	1x230Vac 50/60Hz 0,12A
Amb. Cond.	0 + 40°C (32 + 104°F) 1000m ASL
TRANSDUCER	ENCODER OR RESOLVER (on request)
MOUNTING FORM	B5, B35, or other on request
BRAKE	up to 12 Nm (on request)
DE BEARING	BALL
NDE BEARING	BALL
MAX MECHANICAL SPEED	12000 r.p.m.
PAINTING SYSTEM	NITRO, POLYURETHANIC, C5M, on request

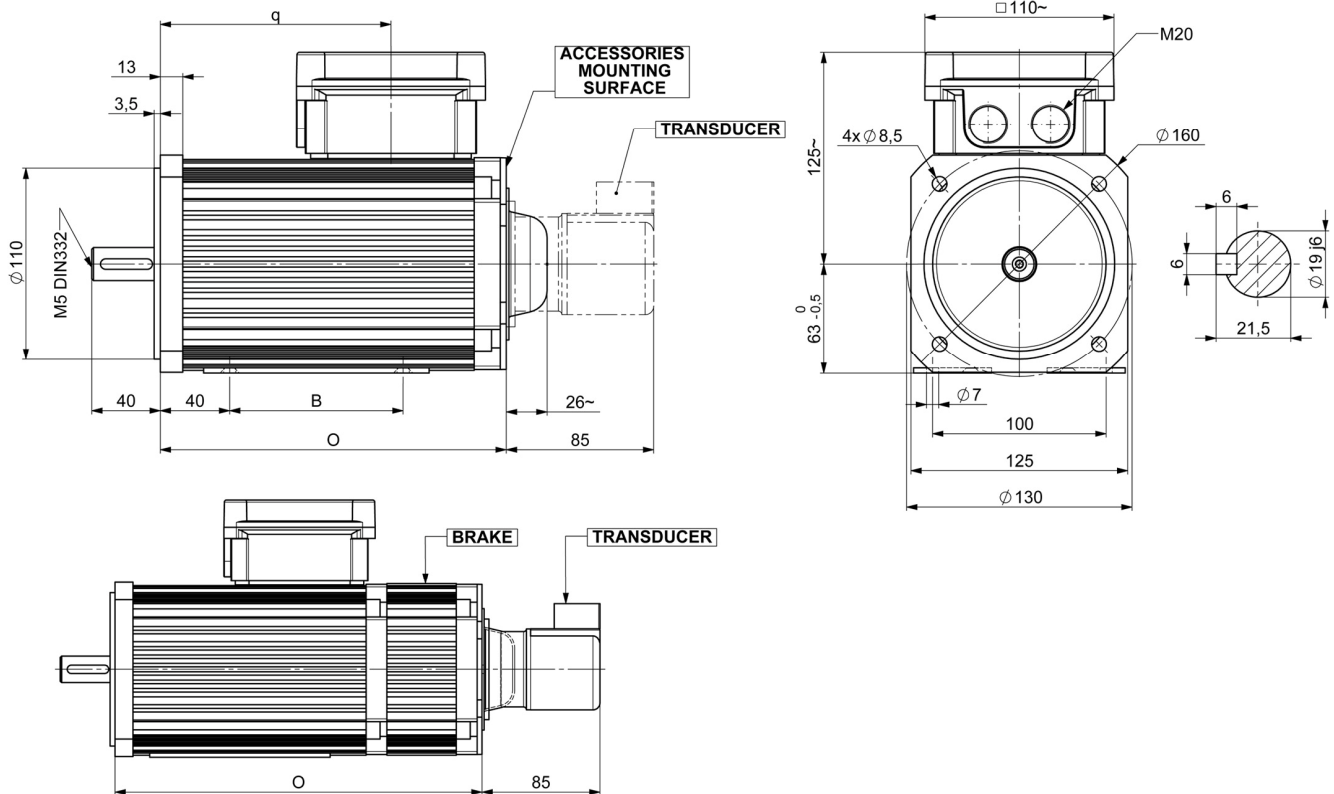

VARIABLES DIMENSIONS BY SIZE				
SIZE	q	B	O	O (with brake)
63.1C	133	100	200	265
63.2C	208	175	275	340

unit [mm]

DRIVE AX 63.1C

Tmax/Tn=3.3		J=0.0017Kgm ²		S1					S6/40%				
Poles: 4													
VOLT	HZ	RPM	slip	L _{arm}	KW	Nm	cosφ	const. power RPM	L _{arm}	KW	Nm	const. power RPM	Eff. S1
380	35	1000	50	0,8	0,27	2,6	0,70	2200	1,1	0,4	3,6	1550	0,73
330	35	1000	50	0,9	0,27	2,6	0,70	2200	1,3	0,4	3,6	1550	0,75
380	52	1500	60	1,2	0,40	2,5	0,70	3300	1,7	0,6	3,6	2350	0,72
330	52	1500	60	1,4	0,40	2,5	0,70	3300	2,0	0,6	3,6	2350	0,71
380	68,5	2000	55	1,7	0,50	2,4	0,70	4400	2,4	0,7	3,3	3100	0,64
331	68,5	2000	55	2,0	0,50	2,4	0,70	4400	2,8	0,7	3,3	3100	0,62
380	102	3000	60	2,5	0,75	2,4	0,70	6600	3,5	1,1	3,3	4650	0,65
330	102	3000	60	2,9	0,75	2,4	0,70	6600	4,1	1,1	3,3	4650	0,65
380	135	4000	50	3,2	0,90	2,1	0,70	8400	4,5	1,3	3,0	5900	0,61
328	135	4000	50	3,7	0,90	2,1	0,70	8400	5,2	1,3	3,0	5900	0,61

DRIVE AX 63.2C

Tmax/Tn=3.3		J=0.0020Kgm ²		S1					S6/40%				
Poles: 4													
VOLT	HZ	RPM	slip	L _{arm}	KW	Nm	cosφ	const. power RPM	L _{arm}	KW	Nm	const. power RPM	Eff. S1
380	35	1000	50	1,7	0,50	4,8	0,70	2300	2,4	0,7	6,7	1650	0,64
330	35	1000	50	1,9	0,50	4,8	0,70	2300	2,7	0,7	6,7	1650	0,66
380	52	1500	60	2,5	0,75	4,8	0,70	3450	3,5	1,1	6,7	2450	0,65
326	52	1500	60	2,9	0,75	4,8	0,70	3450	4,1	1,1	6,7	2450	0,66
380	68,5	2000	55	3,3	1,00	4,8	0,70	4600	4,6	1,4	6,7	3250	0,66
330	68,5	2000	55	3,8	1,00	4,8	0,70	4600	5,3	1,4	6,7	3250	0,66
380	102	3000	60	4,9	1,41	4,5	0,70	6900	6,9	2,0	6,3	4850	0,63
325	102	3000	60	5,7	1,41	4,5	0,70	6900	8,0	2,0	6,3	4850	0,63
380	134,7	4000	41	6,4	1,63	3,9	0,70	8800	9,0	2,3	5,4	6200	0,55
321	134,7	4000	41	7,6	1,63	3,9	0,70	8800	10,6	2,3	5,4	6200	0,55

Note: Speed values must be technically compatible with applied accessories

Other windings on request

POWERTECH DRIVE AX 63CS

ASYNCHRONOUS MOTORS

OVERVIEW

Rev. 1.2

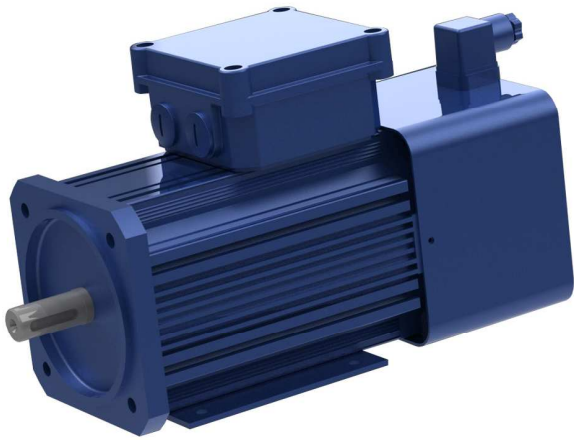

IP PROTECTION	IP54
THERMAL PROTECTION TYPE	KLIXON (PT100, PTC on request)
BALANCING, VIBRATION GRADE (EN 60034-14 / VDE 0530 part 14)	A (B on request)
INSULATION CLASS	F
COOLING METHOD	IC416A
STANDARD FAN DETAILS	1x230Vac 50/60Hz 0,12A
Amb. Cond.	0 + 40°C (32 + 104°F) 1000m ASL
TRANSDUCER	ENCODER OR RESOLVER (on request)
MOUNTING FORM	B5, B35, or other on request
BRAKE	up to 12 Nm (on request)
DE BEARING	BALL
NDE BEARING	BALL
MAX MECHANICAL SPEED	12000 r.p.m.
PAINTING SYSTEM	NITRO, POLYURETHANIC, C5M, on request

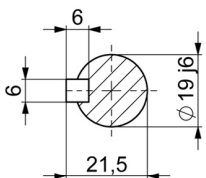
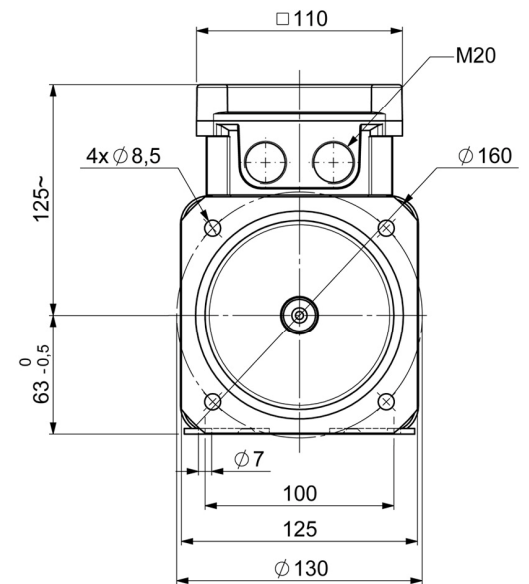
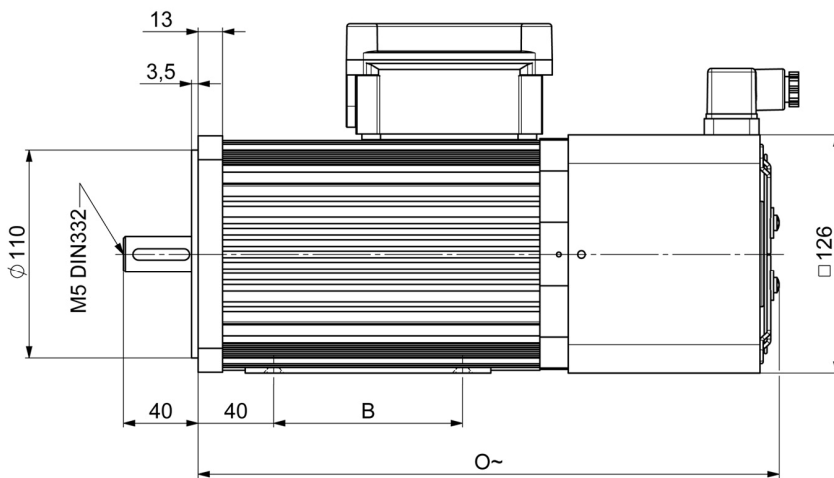

VARIABLES DIMENSIONS BY SIZE

SIZE	B	O
63.1CS	100	300
63.2CS	175	375

unit [mm]

DRIVE AX 63.1CS

Tmax/Tn=3.3		J=0.0017Kgm ²		S1					S6/40%						
Poles: 4															
VOLT	HZ	RPM	slip	L _{arm}	KW	Nm	cosφ	const. power RPM	L _{arm}	KW	Nm	const. power RPM	Eff. S1		
380	36	1000	80	1,50	0,45	4,3	0,70	1700	2,1	0,6	6,0	1200	0,65		
330	36	1000	80	1,73	0,45	4,3	0,70	1700	2,4	0,6	6,0	1200	0,65		
380	52,4	1500	72	2,20	0,65	4,1	0,70	2550	3,1	0,9	5,8	1800	0,64		
330	52,4	1500	72	2,50	0,65	4,1	0,70	2550	3,5	0,9	5,8	1800	0,65		
380	68,7	2000	61	2,80	0,85	4,1	0,70	3400	3,9	1,2	5,7	2400	0,66		
330	68,7	2000	61	3,20	0,85	4,1	0,70	3400	4,5	1,2	5,7	2400	0,66		
380	102	3000	60	4,10	1,25	4,0	0,70	5100	5,7	1,8	5,6	3600	0,66		
328	102	3000	60	4,70	1,25	4,0	0,70	5100	6,6	1,8	5,6	3600	0,67		
380	135	4000	50	4,85	1,50	3,6	0,70	6400	6,8	2,1	5,0	4500	0,67		
328	135	4000	50	5,60	1,50	3,6	0,70	6400	7,8	2,1	5,0	4500	0,67		

DRIVE AX 63.2CS

Tmax/Tn=3.3		J=0.0020Kgm ²		S1					S6/40%						
Poles: 4															
VOLT	HZ	RPM	slip	L _{arm}	KW	Nm	cosφ	const. power RPM	L _{arm}	KW	Nm	const. power RPM	Eff. S1		
380	36,2	1000	86	2,80	0,85	8,1	0,70	1800	3,9	1,2	11,4	1300	0,66		
332	36,2	1000	86	3,20	0,85	8,1	0,70	1800	4,5	1,2	11,4	1300	0,66		
380	52,5	1500	75	4,00	1,20	7,6	0,70	2700	5,6	1,7	10,7	1900	0,65		
326	52,5	1500	75	4,65	1,20	7,6	0,70	2700	6,5	1,7	10,7	1900	0,65		
380	68,8	2000	64	5,20	1,60	7,6	0,70	3600	7,3	2,2	10,7	2550	0,67		
329	68,8	2000	64	6,00	1,60	7,6	0,70	3600	8,4	2,2	10,7	2550	0,67		
380	102	3000	60	7,00	2,20	7,0	0,70	5400	9,8	3,1	9,8	3800	0,68		
331	102	3000	60	8,00	2,20	7,0	0,70	5400	11,2	3,1	9,8	3800	0,69		
380	135	4000	50	8,20	2,60	6,2	0,70	6400	11,5	3,6	8,7	4500	0,69		
332	135	4000	50	9,40	2,60	6,2	0,70	6400	13,2	3,6	8,7	4500	0,69		

Note: Speed values must be technically compatible with applied accessories

Other windings on request

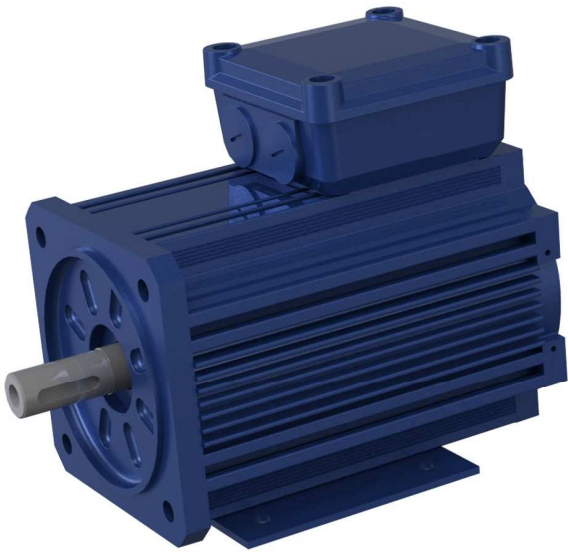

IP PROTECTION	IP54
THERMAL PROTECTION TYPE	KLIXON (PT100, PTC on request)
BALANCING, VIBRATION GRADE (EN 60034-14 / VDE 0530 part 14)	A (B on request)
INSULATION CLASS	F
COOLING METHOD	IC410 (IC416A on request)
STANDARD FAN (IC416A only)	1x230Vac 50/60Hz 0,30A
Amb. Cond.	0 + 40°C (32 + 104°F) 1000m ASL
TRANSDUCER	ENCODER OR RESOLVER (on request)
MOUNTING FORM	B5, B35, or other on request
BRAKE	up to 23 Nm (on request)
DE BEARING	BALL
NDE BEARING	BALL
MAX MECHANICAL SPEED	10000 r.p.m.
PAINTING SYSTEM	NITRO, POLYURETHANIC, C5M, on request

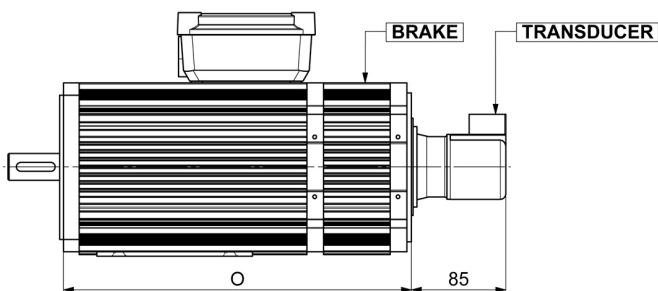
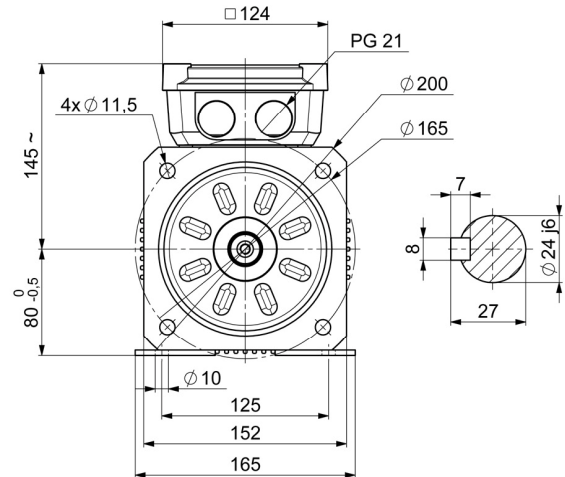
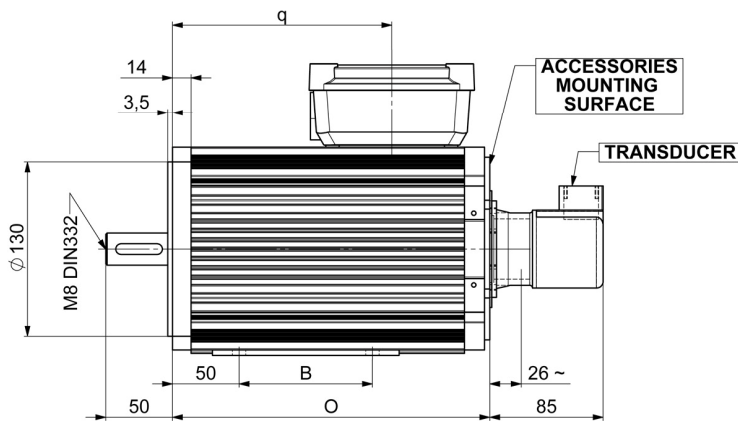

VARIABLES DIMENSIONS BY SIZE				
SIZE	q	B	O	O (with brake)
80.1C	165	100	235	315
80.2C	210	145	280	360
80.3C	280	215	350	430

unit [mm]

DRIVE AX 80.1C

Tmax/Tn=3.3		J=0.0029Kgm ²		S1					S6/40%				
Poles: 4													
VOLT	HZ	RPM	slip	L _{arm}	KW	Nm	cos φ	const. power max RPM	L _{arm}	KW	Nm	const. power max RPM	Eff. S1
380	35,3	1000	59	1,8	0,73	7,0	0,79	2200	2,5	1,0	9,8	1550	0,78
330	35,3	1000	59	2,1	0,73	7,0	0,79	2200	2,9	1,0	9,8	1550	0,77
380	52	1500	60	2,7	1,10	7,0	0,79	3300	3,8	1,5	9,8	2350	0,78
331	52	1500	60	3,1	1,10	7,0	0,79	3300	4,3	1,5	9,8	2350	0,78
380	68,5	2000	55	3,6	1,40	6,7	0,77	4400	5,0	2,0	9,4	3100	0,77
325	68,5	2000	55	4,2	1,40	6,7	0,77	4400	5,9	2,0	9,4	3100	0,77
380	101,3	3000	39	5,1	2,00	6,4	0,76	6300	7,1	2,8	8,9	4450	0,78
325	101,3	3000	39	6,0	2,00	6,4	0,76	6300	8,4	2,8	8,9	4450	0,78
380	134,7	4000	41	6,8	2,45	5,9	0,75	8400	9,5	3,4	8,2	5900	0,73
325	134,7	4000	41	8,0	2,45	5,9	0,75	8400	11,2	3,4	8,2	5900	0,73

DRIVE AX 80.2C

Tmax/Tn=3.3		J=0.0040Kgm ²		S1					S6/40%				
Poles: 4													
VOLT	HZ	RPM	slip	L _{arm}	KW	Nm	cos φ	const. power max RPM	L _{arm}	KW	Nm	const. power max RPM	Eff. S1
380	35	1000	50	2,5	1,00	9,6	0,78	2300	3,5	1,4	13,4	1650	0,78
327	35	1000	50	2,9	1,00	9,6	0,78	2300	4,1	1,4	13,4	1650	0,78
380	52	1500	60	3,7	1,50	9,6	0,77	3450	5,2	2,1	13,4	2450	0,80
330	52	1500	60	4,2	1,50	9,6	0,77	3450	5,9	2,1	13,4	2450	0,81
380	68,5	2000	55	5,0	2,00	9,6	0,77	4600	7,0	2,8	13,4	3250	0,79
327	68,5	2000	55	5,8	2,00	9,6	0,77	4600	8,1	2,8	13,4	3250	0,79
380	101,3	3000	39	7,2	2,70	8,6	0,76	6900	10,1	3,8	12,0	4850	0,75
324	101,3	3000	39	8,4	2,70	8,6	0,76	6900	11,8	3,8	12,0	4850	0,75
380	134,7	4000	41	9,2	3,40	8,1	0,76	8800	12,9	4,8	11,4	6200	0,74
330	134,7	4000	41	10,6	3,40	8,1	0,76	8800	14,8	4,8	11,4	6200	0,74

Note: Speed values must be technically compatible with applied accessories

DRIVE AX 80.3C

Tmax/Tn=3.3		J=0.0058Kgm ²		S1					S6/40%				
Poles: 4													
VOLT	HZ	RPM	slip	L _{arm}	KW	Nm	cos φ	const. power max RPM	L _{arm}	KW	Nm	const. power max RPM	Eff. S1
380	35	1000	50	3,2	1,40	13,4	0,79	2400	4,5	2,0	18,7	1700	0,84
330	35	1000	50	3,7	1,40	13,4	0,79	2400	5,2	2,0	18,7	1700	0,84
380	52	1500	60	4,9	2,10	13,4	0,79	3600	6,9	2,9	18,7	2550	0,83
322	52	1500	60	5,6	2,10	13,4	0,79	3600	7,8	2,9	18,7	2550	0,85
380	68,5	2000	55	6,6	2,80	13,4	0,77	4800	9,2	3,9	18,7	3400	0,84
341	68,5	2000	55	7,6	2,80	13,4	0,77	4800	10,6	3,9	18,7	3400	0,81
380	99,5	2950	35	9,3	3,80	12,3	0,76	6800	13,0	5,3	17,2	4800	0,82
325	99,5	2950	35	10,7	3,80	12,3	0,76	6800	15,0	5,3	17,2	4800	0,83
380	139	4140	30	12,8	5,00	11,5	0,75	9000	17,9	7,0	16,1	6300	0,79
340	139	4140	30	13,9	5,00	11,5	0,75	9000	19,5	7,0	16,1	6300	0,82

Note: Speed values must be technically compatible with applied accessories

Other windings on request

POWERTECH DRIVE AX 80CS

ASYNCHRONOUS MOTORS

OVERVIEW

Rev. 1.2



IP PROTECTION	IP54
THERMAL PROTECTION TYPE	KLIXON (PT100, PTC on request)
BALANCING, VIBRATION GRADE (EN 60034-14 / VDE 0530 part 14)	A (B on request)
INSULATION CLASS	F
COOLING METHOD	IC416A
STANDARD FAN DETAILS	1x230Vac 50/60Hz 0,30A
Amb. Cond.	0 + 40°C (32 + 104°F) 1000m ASL
TRANSDUCER	ENCODER OR RESOLVER (on request)
MOUNTING FORM	B5, B35, or other on request
BRAKE	up to 23 Nm (on request)
DE BEARING	BALL
NDE BEARING	BALL
MAX MECHANICAL SPEED	10000 r.p.m.
PAINTING SYSTEM	NITRO, POLYURETHANIC, C5M, on request

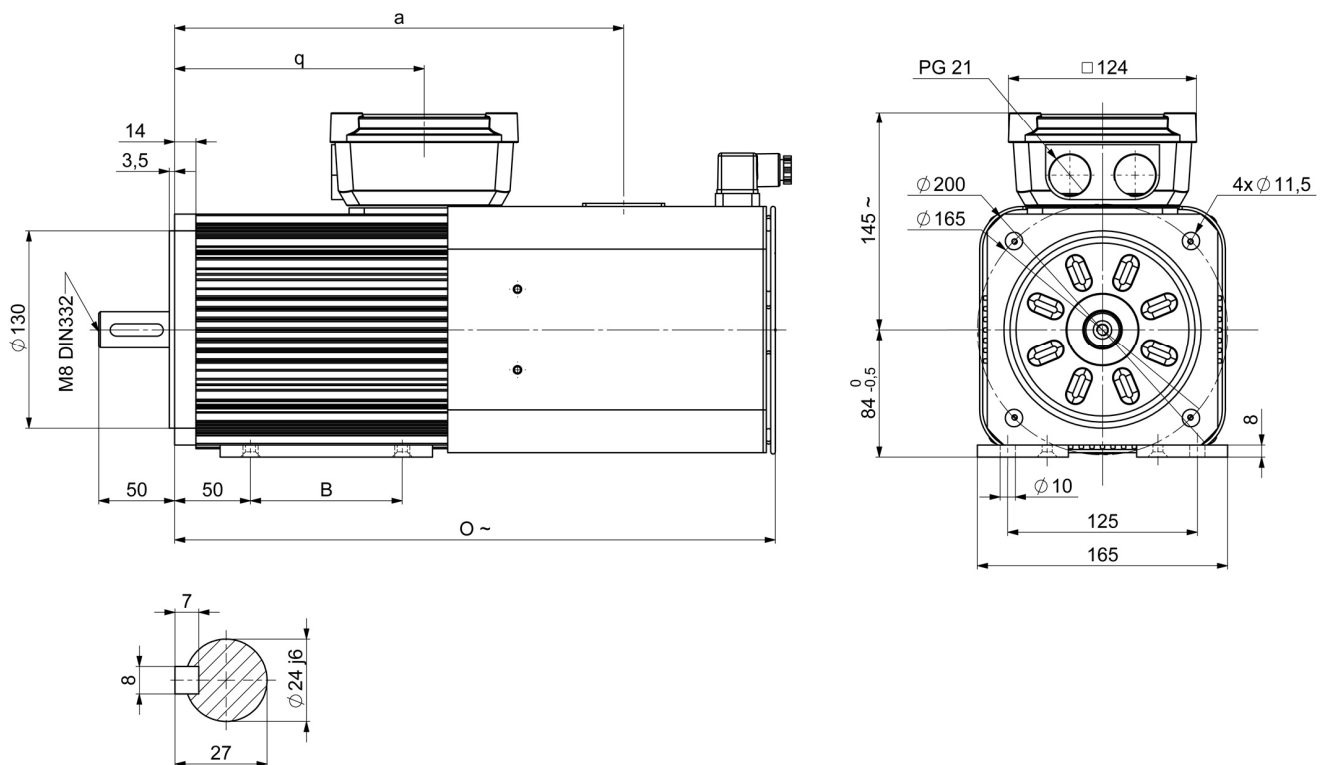

VARIABLES DIMENSIONS BY SIZE

SIZE	a ~	q	B	O
80.1CS	296	165	100	400
80.2CS	341	210	145	445
80.3CS	411	280	215	515

unit [mm]

DRIVE AX 80.1CS

Tmax/Tn=3.3		J=0.0029Kgm ²		S1					S6/40%				
Poles: 4													
VOLT	HZ	RPM	slip	L _{arm}	KW	Nm	cosφ	const. power RPM	L _{arm}	KW	Nm	const. power RPM	Eff. S1
380	36,7	1000	101	3,5	1,4	13,4	0,79	1600	4,9	2,0	18,7	1150	0,77
334	36,7	1000	101	4,0	1,4	13,4	0,79	1600	5,6	2,0	18,7	1150	0,77
380	55,2	1550	106	5,0	2,2	13,6	0,79	2500	7,0	3,1	19,0	1750	0,85
341	55,2	1550	106	5,6	2,2	13,6	0,79	2500	7,8	3,1	19,0	1750	0,84
380	71	2025	105	6,9	2,8	13,2	0,77	3450	9,7	3,9	18,5	2450	0,80
331	71	2025	105	8,0	2,8	13,2	0,77	3450	11,2	3,9	18,5	2450	0,79
380	104,5	3035	100	9,0	3,9	12,3	0,76	4900	12,6	5,5	17,2	3450	0,87
328	104,5	3035	100	10,5	3,9	12,3	0,76	4900	14,7	5,5	17,2	3450	0,86
380	136,8	4000	104	11,2	4,8	11,5	0,75	6400	15,7	6,7	16,0	4500	0,87
328	136,8	4000	104	13,0	4,8	11,5	0,75	6400	18,2	6,7	16,0	4500	0,87
380	158,5	4650	105	12,5	5,3	10,9	0,75	7450	17,5	7,4	15,2	5250	0,86

DRIVE AX 80.2CS

Tmax/Tn=3.3		J=0.0040Kgm ²		S1					S6/40%				
Poles: 4													
VOLT	HZ	RPM	slip	L _{arm}	KW	Nm	cosφ	const. power RPM	L _{arm}	KW	Nm	const. power RPM	Eff. S1
380	37,5	1020	105,5	5,0	2,0	18,7	0,78	1750	7,0	2,8	26,2	1250	0,78
335	37,5	1020	105,5	5,7	2,0	18,7	0,78	1750	8,0	2,8	26,2	1250	0,78
380	53,8	1510	104	7,0	3,0	19,0	0,79	2750	9,8	4,2	26,6	1950	0,83
326	53,8	1510	104	8,2	3,0	19,0	0,79	2750	11,5	4,2	26,6	1950	0,82
380	74,3	2130	99	9,5	4,0	17,9	0,77	3850	13,3	5,6	25,1	2700	0,83
326	74,3	2130	99	11,0	4,0	17,9	0,77	3850	15,4	5,6	25,1	2700	0,84
380	105,3	3080	79	12,4	5,3	16,4	0,76	5250	17,4	7,4	23,0	3700	0,86
330	105,3	3080	79	14,3	5,3	16,4	0,76	5250	20,0	7,4	23,0	3700	0,85
380	140,5	4140	75	16,1	6,8	15,7	0,75	7050	22,5	9,5	22,0	4950	0,86
318	140,5	4140	75	19,4	6,8	15,7	0,75	7050	27,2	9,5	22,0	4950	0,85

Note: Speed values must be technically compatible with applied accessories

DRIVE AX 80.3CS

Tmax/Tn=3.3		J=0.0058Kgm ²		S1					S6/40%				
Poles: 4													
VOLT	HZ	RPM	slip	L _{arm}	KW	Nm	cosφ	const. power RPM	L _{arm}	KW	Nm	const. power RPM	Eff. S1
380	37,7	1030	101	6,8	2,8	26,0	0,79	1900	9,5	3,9	36,3	1350	0,79
338	37,7	1030	101	7,6	2,8	26,0	0,79	1900	10,6	3,9	36,3	1350	0,80
380	54,1	1520	103	9,8	4,1	25,8	0,79	2750	13,7	5,7	36,1	1950	0,81
340	54,1	1520	103	11,0	4,1	25,8	0,79	2750	15,4	5,7	36,1	1950	0,80
380	75	2150	100	13,6	5,7	25,3	0,77	3900	19,0	8,0	35,5	2750	0,83
326	75	2150	100	15,7	5,7	25,3	0,77	3900	22,0	8,0	35,5	2750	0,84
380	109,5	3190	95	17,9	7,7	23,1	0,76	5750	25,1	10,8	32,3	4050	0,86
341	109,5	3190	95	20,0	7,7	23,1	0,76	5450	28,0	10,8	32,3	3850	0,86
380	142	4170	90	22,7	9,5	21,8	0,75	7100	31,8	13,3	30,5	5000	0,85
333	142	4170	90	26,0	9,5	21,8	0,75	7100	36,4	13,3	30,5	5000	0,85

Note: Speed values must be technically compatible with applied accessories

Other windings on request

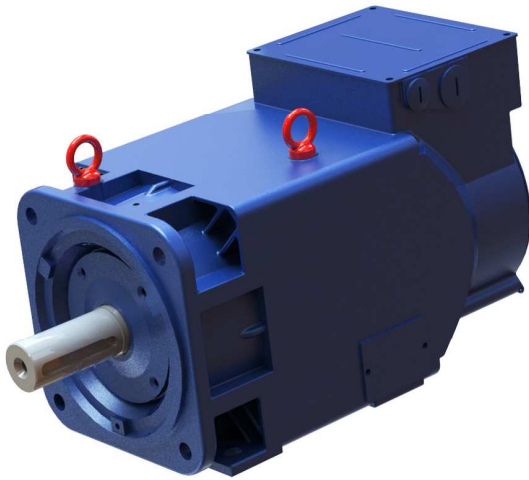

IP PROTECTION	IP54
THERMAL PROTECTION TYPE	KLIXON (PT100, PTC on request)
BALANCING, VIBRATION GRADE (EN 60034-14 / VDE 0530 part 14)	A (B on request)
INSULATION CLASS	F
COOLING METHOD	IC416A
STANDARD FAN DETAILS	3x400Vac 50/60Hz 0,13/0,09A
Amb. Cond.	0 + 40°C (32 + 104°F) 1000m ASL
TRANSDUCER	ENCODER OR RESOLVER (on request)
MOUNTING FORM	B3, B35, or other on request
BRAKE	up to 95 Nm (on request)
DE BEARING	BALL (ROLLER on request)
NDE BEARING	BALL
MAX MECHANICAL SPEED	9000 r.p.m. (4500 r.p.m. roller bearing) 12000 r.p.m. (S4 version)
PAINTING SYSTEM	NITRO, POLYURETHANIC, C5M, on request

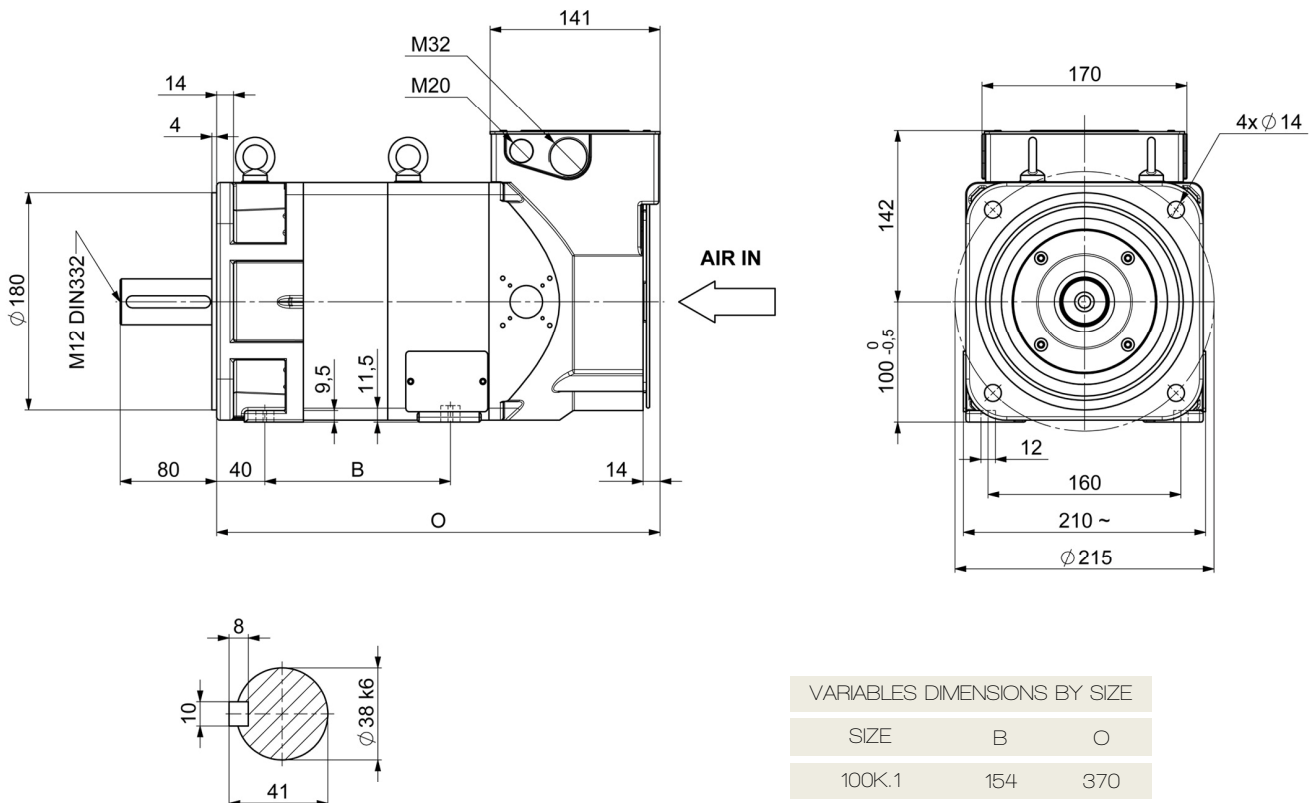

VARIABLES DIMENSIONS BY SIZE		
SIZE	B	O
100K.1	154	370
100K.2	179	395
100K.3	214	430
100K.4	264	480
100K.5	304	520
100K.6	349	565

unit [mm]

DRIVE AX 100K.1

S4 VERSION POWER DERATING: -5%

Tmax/Tn=3.3		J=0.0062Kgm ²		S1					S6/40%				
Poles: 4													
VOLT	HZ	RPM	slip	L _{arm}	KW	Nm	cosφ	const. power RPM	L _{arm}	KW	Nm	const. power RPM	Eff. S1
380	35,5	1010	55	5,0	2,0	18,9	0,75	1550	7,0	2,8	26,5	1100	0,81
330	35,5	1010	55	5,7	2,0	18,9	0,78	1550	8,0	2,8	26,5	1100	0,79
380	52,4	1520	52	7,0	3,0	18,9	0,77	2450	9,8	4,2	26,4	1750	0,85
336	52,4	1520	52	8,1	3,0	18,9	0,77	2450	11,3	4,2	26,4	1750	0,83
380	70,5	2070	45	9,5	4,1	18,9	0,77	3350	13,3	5,7	26,5	2350	0,85
332	70,5	2070	45	10,8	4,1	18,9	0,77	3350	15,1	5,7	26,5	2350	0,86
380	102,7	3040	41	11,7	5,0	15,7	0,76	5200	16,4	7,0	22,0	3650	0,86
330	102,7	3040	41	13,4	5,0	15,7	0,76	5200	18,8	7,0	22,0	3650	0,86
380	134,5	4000	35	14,2	6,0	14,3	0,75	6800	19,9	8,4	20,1	4800	0,86
338	134,5	4000	35	16,0	6,0	14,3	0,75	6800	22,4	8,4	20,1	4800	0,86

Tmax/Tn=3.3		J=0.0062Kgm ²		S1					S6/40%				
Poles: 4													
VOLT	HZ	RPM	slip	L _{arm}	KW	Nm	cosφ	const. power RPM	L _{arm}	KW	Nm	const. power RPM	Eff. S1
400	37,4	1070	51	5,0	2,1	18,9	0,75	1650	7,0	3,0	26,5	1150	0,81
400	55,2	1600	55	7,0	3,2	18,9	0,77	2600	9,8	4,4	26,4	1850	0,85
400	74,2	2180	46	9,5	4,3	18,9	0,77	3550	13,3	6,0	26,5	2450	0,85
400	108,1	3200	43	11,7	5,3	15,7	0,76	5450	16,4	7,4	22,0	3850	0,86
400	141,6	4210	37	14,2	6,3	14,3	0,75	7150	19,9	8,8	20,1	5050	0,86

Tmax/Tn=3.3		J=0.0062Kgm ²		S1					S6/40%				
Poles: 4													
VOLT	HZ	RPM	slip	L _{arm}	KW	Nm	cosφ	const. power RPM	L _{arm}	KW	Nm	const. power RPM	Eff. S1
460	35,4	1010	53	4,1	2,0	18,9	0,75	1550	5,7	2,8	26,5	1100	0,82
460	52,5	1520	55	5,8	3,0	18,9	0,77	2450	8,1	4,2	26,4	1750	0,84
460	70,2	2060	46	7,8	4,1	19,0	0,77	3300	10,9	5,7	26,6	2350	0,86
460	102,2	3025	41	9,7	5,0	15,8	0,76	5150	13,6	7,0	22,1	3650	0,85
460	133,1	3960	33	11,7	6,0	14,5	0,75	6750	16,4	8,4	20,3	4750	0,86

Note: Speed values must be technically compatible with bearings type and applied accessories

DRIVE AX 100K.2

S4 VERSION POWER DERATING: -5%

Tmax/Tn=3.3		J=0.0075Kgm ²		S1					S6/40%						
Poles: 4															
VOLT	HZ	RPM	slip	L _{arm}	KW	Nm	cosφ	const. power RPM	L _{arm}	KW	Nm	const. power RPM	Eff. S1		
380	35,65	1020	50	6,5	2,8	26,0	0,78	1650	9,1	3,9	36,5	1200	0,83		
330	35,65	1020	50	7,5	2,8	26,2	0,78	1650	10,5	3,9	36,7	1200	0,84		
380	52,1	1510	53	9,3	4,0	25,3	0,77	2450	13,0	5,6	35,4	1750	0,85		
320	52,1	1510	53	11,0	4,0	25,3	0,77	2450	15,4	5,6	35,4	1750	0,85		
380	72,8	2130	54	12,8	5,6	25,1	0,77	3650	17,9	7,8	35,2	2600	0,86		
330	72,8	2130	54	14,8	5,6	25,1	0,77	3650	20,7	7,8	35,2	2600	0,86		
380	104,0	3080	40	15,4	6,8	21,1	0,76	5400	21,6	9,5	29,5	3800	0,88		
335	104,0	3080	40	17,4	6,8	21,1	0,76	5400	24,4	9,5	29,5	3800	0,89		
380	139,0	4140	30	19,5	8,4	19,4	0,76	7250	27,3	11,8	27,1	5100	0,86		
322	139,0	4140	30	23,0	8,4	19,4	0,76	7250	32,2	11,8	27,1	5100	0,86		

Tmax/Tn=3.3		J=0.0075Kgm ²		S1					S6/40%						
Poles: 4															
VOLT	HZ	RPM	slip	L _{arm}	KW	Nm	cosφ	const. power RPM	L _{arm}	KW	Nm	const. power RPM	Eff. S1		
400	37,5	1080	46	6,5	2,9	26,0	0,78	1750	9,1	4,1	36,5	1250	0,83		
400	54,8	1590	55	9,3	4,2	25,3	0,77	2600	13,0	5,9	35,4	1850	0,85		
400	76,6	2250	49	12,8	5,9	25,1	0,77	3850	17,9	8,3	35,2	2750	0,86		
400	109,5	3240	44	15,4	7,2	21,1	0,76	5700	21,6	10,0	29,5	4000	0,88		
400	146,3	4360	29	19,5	8,8	19,4	0,76	7650	27,3	12,4	27,1	5350	0,86		

Tmax/Tn=3.3		J=0.0075Kgm ²		S1					S6/40%						
Poles: 4															
VOLT	HZ	RPM	slip	L _{arm}	KW	Nm	cosφ	const. power RPM	L _{arm}	KW	Nm	const. power RPM	Eff. S1		
460	34,1	970	53	5,2	2,7	26,0	0,78	1600	7,3	3,8	36,5	1150	0,84		
460	51,8	1500	54	7,7	4,0	25,3	0,77	2400	10,8	5,6	35,4	1700	0,85		
460	72,4	2120	52	10,6	5,6	25,1	0,77	3650	14,8	7,8	35,2	2600	0,86		
460	101,9	3020	37	12,5	6,7	21,1	0,76	5300	17,5	9,4	29,5	3750	0,89		
460	136,8	4070	34	15,9	8,3	19,4	0,76	7150	22,3	11,6	27,1	5050	0,86		

Note: Speed values must be technically compatible with bearings type and applied accessories

DRIVE AX 100K.3

S4 VERSION POWER DERATING: -5%

Tmax/Tn=3.5		J=0.0102Kgm ²		S1					S6/40%						
Poles: 4															
VOLT	HZ	RPM	slip	L _{arm}	KW	Nm	cosφ	const. power RPM	L _{arm}	KW	Nm	const. power RPM	Eff. S1		
380	35,7	1020	51	8,8	3,8	35,6	0,79	1750	12,3	5,3	49,8	1250	0,83		
334	35,7	1020	51	9,8	3,8	35,6	0,79	1750	13,7	5,3	49,8	1250	0,85		
380	53,3	1550	49	12,6	5,6	34,5	0,79	2750	17,6	7,8	48,3	1950	0,86		
330	53,3	1550	49	14,7	5,6	34,5	0,78	2750	20,6	7,8	48,3	1950	0,86		
380	72,4	2120	52	17,0	7,6	34,2	0,78	3750	23,8	10,6	47,9	2650	0,87		
335	72,4	2120	52	19,4	7,6	34,2	0,78	3750	27,2	10,6	47,9	2650	0,87		
380	107,3	3170	49	21,5	9,6	28,9	0,77	5750	30,1	13,4	40,5	4050	0,88		
348	107,3	3170	49	23,5	9,6	28,9	0,77	5750	32,9	13,4	40,5	4050	0,88		
380	147,3	4390	29	26,6	12,0	26,1	0,78	7950	37,2	16,8	36,6	5600	0,88		
338	147,3	4390	29	30,1	12,0	26,1	0,78	7950	42,1	16,8	36,6	5600	0,87		

Tmax/Tn=3.5		J=0.0102Kgm ²		S1					S6/40%						
Poles: 4															
VOLT	HZ	RPM	slip	L _{arm}	KW	Nm	cosφ	const. power RPM	L _{arm}	KW	Nm	const. power RPM	Eff. S1		
400	37,6	1080	47	8,8	4,0	35,6	0,79	1850	12,3	5,6	49,8	1300	0,83		
400	56,1	1630	53	12,6	5,9	34,5	0,79	2900	17,6	8,2	48,3	2050	0,86		
400	76,2	2230	56	17,0	8,0	34,2	0,78	3950	23,8	11,2	47,9	2800	0,87		
400	112,9	3340	48	21,5	10,1	28,9	0,77	6050	30,1	14,2	40,5	4250	0,88		
400	155,1	4620	32	26,6	12,6	26,1	0,78	8350	37,2	17,7	36,6	5900	0,88		

Tmax/Tn=3.5		J=0.0102Kgm ²		S1					S6/40%						
Poles: 4															
VOLT	HZ	RPM	slip	L _{arm}	KW	Nm	cosφ	const. power RPM	L _{arm}	KW	Nm	const. power RPM	Eff. S1		
460	35,7	1020	51	7,2	3,8	35,6	0,79	1750	10,1	5,3	49,8	1250	0,84		
460	52,9	1540	47	10,4	5,6	34,5	0,79	2700	14,6	7,8	48,3	1900	0,86		
460	70,9	2080	47	13,7	7,4	34,2	0,78	3650	19,2	10,4	47,9	2600	0,87		
460	103,9	3070	47	17,2	9,3	28,9	0,77	5550	24,1	13,0	40,5	3900	0,88		
460	145,7	4330	41	21,6	11,8	26,1	0,78	7800	30,2	16,5	36,6	5500	0,88		

Note: Speed values must be technically compatible with bearings type and applied accessories

DRIVE AX 100K.4

S4 VERSION POWER DERATING: -5%

Tmax/Tn=3.5		J=0.0142Kgm ²		S1					S6/40%				
Poles: 4													
VOLT	HZ	RPM	slip	L _{arm}	KW	Nm	cosφ	const. power RPM	L _{arm}	KW	Nm	const. power RPM	Eff. S1
380	38,9	1110	57	12,5	5,5	47,3	0,80	1950	17,5	7,7	66,3	1400	0,84
328	38,9	1110	57	14,7	5,5	47,3	0,80	1950	20,6	7,7	66,3	1400	0,82
380	52,3	1510	59	17,0	7,5	47,4	0,79	2800	23,8	10,5	66,4	2000	0,85
335	52,3	1510	59	19,2	7,5	47,4	0,79	2800	26,9	10,5	66,4	2000	0,85
380	74,5	2180	55	23,0	10,5	46,0	0,79	4050	32,2	14,7	64,4	2850	0,88
348	74,5	2180	55	25,3	10,5	46,0	0,79	4050	35,4	14,7	64,4	2850	0,87
380	104,5	3090	45	28,4	12,8	39,6	0,78	5750	39,8	17,9	55,4	4050	0,88
338	104,5	3090	45	32,0	12,8	39,6	0,78	5750	44,8	17,9	55,4	4050	0,88
380	138,0	4100	40	35,0	15,5	36,1	0,77	7600	49,0	21,7	50,6	5350	0,87
350	138,0	4100	40	38,0	15,5	36,1	0,77	7600	53,2	21,7	50,6	5350	0,87

Tmax/Tn=3.5		J=0.0142Kgm ²		S1					S6/40%				
Poles: 4													
VOLT	HZ	RPM	slip	L _{arm}	KW	Nm	cosφ	const. power RPM	L _{arm}	KW	Nm	const. power RPM	Eff. S1
400	40,9	1170	58	12,5	5,8	47,3	0,80	2050	17,5	8,1	66,3	1450	0,84
400	55,1	1590	62	17,0	7,9	47,4	0,79	2950	23,8	11,1	66,4	2100	0,85
400	78,4	2300	53	23,0	11,1	46,0	0,79	4250	32,2	15,5	64,4	3000	0,88
400	110,0	3260	40	28,4	13,5	39,6	0,78	6050	39,8	18,9	55,4	4250	0,88
400	145,3	4320	38	35,0	16,3	36,1	0,77	8000	49,0	22,9	50,6	5650	0,88

Tmax/Tn=3.5		J=0.0142Kgm ²		S1					S6/40%				
Poles: 4													
VOLT	HZ	RPM	slip	L _{arm}	KW	Nm	cosφ	const. power RPM	L _{arm}	KW	Nm	const. power RPM	Eff. S1
460	38,4	1100	52	10,3	5,5	47,3	0,80	1950	14,5	7,7	66,3	1400	0,84
460	53,8	1560	54	14,2	7,7	47,4	0,80	2900	19,9	10,8	66,4	2050	0,85
460	77,3	2270	49	19,5	10,9	46,0	0,80	4200	27,3	15,3	64,4	2950	0,88
460	103,5	3060	45	23,3	12,7	39,6	0,78	5700	32,6	17,8	55,4	4000	0,88
460	145,7	4330	41	29,8	16,0	36,1	0,77	8050	41,8	22,4	50,6	5650	0,88

Note: Speed values must be technically compatible with bearings type and applied accessories

DRIVE AX 100K.5

S4 VERSION POWER DERATING: -5%

Tmax/Tn=3.5		J=0.0168Kgm ²		S1					S6/40%				
Poles: 4													
VOLT	HZ	RPM	slip	L _{arm}	KW	Nm	cosφ	const. power RPM	L _{arm}	KW	Nm	const. power RPM	Eff. S1
380	38,9	1110	57	15,0	6,7	57,7	0,81	2450	21,0	9,4	80,7	1750	0,84
338	38,9	1110	57	17,0	6,7	57,7	0,81	2450	23,8	9,4	80,7	1750	0,83
380	51,9	1510	47	20,2	9,0	56,9	0,80	3500	28,3	12,6	79,7	2450	0,85
325	51,9	1510	47	23,6	9,0	56,9	0,80	3500	33,0	12,6	79,7	2450	0,85
380	73,0	2140	50	27,9	12,8	57,1	0,80	4950	39,1	17,9	80,0	3500	0,87
341	73,0	2140	50	31,1	12,8	57,1	0,80	4950	43,5	17,9	80,0	3500	0,87
380	102,5	3030	45	32,5	15,0	47,3	0,79	6700	45,5	21,0	66,2	4700	0,89
322	102,5	3030	45	38,3	15,0	47,3	0,79	6700	53,6	21,0	66,2	4700	0,89
380	135,5	4020	45	39,5	18,0	42,8	0,78	8450	55,3	25,2	59,9	5950	0,89
342	135,5	4020	45	44,0	18,0	42,8	0,78	8450	61,6	25,2	59,9	5950	0,89

Tmax/Tn=3.5		J=0.0168Kgm ²		S1					S6/40%				
Poles: 4													
VOLT	HZ	RPM	slip	L _{arm}	KW	Nm	cosφ	const. power RPM	L _{arm}	KW	Nm	const. power RPM	Eff. S1
400	40,9	1170	58	15,0	7,1	57,7	0,81	2600	21,0	9,9	80,7	1850	0,84
400	54,6	1590	49	20,2	9,5	56,9	0,80	3700	28,3	13,3	79,7	2600	0,85
400	76,8	2250	55	27,9	13,5	57,1	0,80	5200	39,1	18,9	80,0	3700	0,87
400	107,9	3190	47	32,5	15,8	47,3	0,79	7050	45,5	22,1	66,2	4950	0,89
400	142,6	4230	49	39,5	18,9	42,8	0,78	8900	55,3	26,5	59,9	6250	0,89

Tmax/Tn=3.5		J=0.0168Kgm ²		S1					S6/40%				
Poles: 4													
VOLT	HZ	RPM	slip	L _{arm}	KW	Nm	cosφ	const. power RPM	L _{arm}	KW	Nm	const. power RPM	Eff. S1
460	38,5	1100	55	12,4	6,7	57,7	0,81	2450	17,3	9,4	80,7	1750	0,84
460	51,9	1510	47	16,7	9,0	56,9	0,80	3500	23,4	12,6	79,7	2450	0,85
460	73,7	2160	51	23,2	12,9	57,1	0,80	5000	32,5	18,1	80,0	3500	0,87
460	103,5	3060	45	27,0	15,1	47,3	0,79	6750	37,8	21,1	66,2	4750	0,89
460	136,8	4060	44	33,0	18,2	42,8	0,78	8550	46,2	25,5	59,9	6000	0,89

Note: Speed values must be technically compatible with bearings type and applied accessories

DRIVE AX 100K.6

S4 VERSION POWER DERATING: -5%

Tmax/Tn=3.5		J=0.0198Kgm ²		S1					S6/40%				
Poles: 4													
VOLT	HZ	RPM	slip	L _{arm}	KW	Nm	cosφ	const. power RPM	L _{arm}	KW	Nm	const. power RPM	Eff. S1
380	38,8	1110	54	18,6	8,3	71,4	0,81	2500	26,0	11,6	100,0	1750	0,84
305	38,8	1110	54	23,2	8,3	71,4	0,81	2500	32,5	11,6	100,0	1750	0,84
380	54,9	1590	57	25,0	11,5	69,1	0,80	3700	35,0	16,1	96,7	2600	0,87
345	54,9	1590	57	27,6	11,5	69,1	0,80	3700	38,6	16,1	96,7	2600	0,87
380	67,5	1975	50	30,5	14,0	67,7	0,80	4750	42,7	19,6	94,8	3350	0,87
338	67,5	1975	50	34,3	14,0	67,7	0,80	4750	48,0	19,6	94,8	3350	0,87
380	100,5	2985	30	39,0	18,0	57,6	0,79	6900	54,6	25,2	80,6	4850	0,89
345	100,5	2985	30	43,0	18,0	57,6	0,79	6900	60,2	25,2	80,6	4850	0,89
380	125,0	3720	30	44,0	20,0	51,3	0,78	8200	61,6	28,0	71,9	5750	0,89
338	125,0	3720	30	49,5	20,0	51,3	0,78	8200	69,3	28,0	71,9	5750	0,89

Tmax/Tn=3.5		J=0.0198Kgm ²		S1					S6/40%				
Poles: 4													
VOLT	HZ	RPM	slip	L _{arm}	KW	Nm	cosφ	const. power RPM	L _{arm}	KW	Nm	const. power RPM	Eff. S1
400	40,8	1170	55	18,6	8,8	71,4	0,81	2650	26,0	12,3	100,0	1850	0,84
400	57,8	1680	54	25,0	12,1	69,1	0,80	3900	35,0	17,0	96,7	2750	0,88
400	71,1	2080	52	30,5	14,7	67,7	0,80	5000	42,7	20,6	94,8	3550	0,87
400	105,8	3140	34	39,0	18,9	57,6	0,79	7250	54,6	26,5	80,6	5100	0,89
400	131,6	3920	27	44,0	21,1	51,3	0,78	8650	61,6	29,5	71,9	6050	0,89

Tmax/Tn=3.5		J=0.0198Kgm ²		S1					S6/40%				
Poles: 4													
VOLT	HZ	RPM	slip	L _{arm}	KW	Nm	cosφ	const. power RPM	L _{arm}	KW	Nm	const. power RPM	Eff. S1
460	39,1	1120	53	15,4	8,3	71,4	0,81	2550	21,5	11,6	100,0	1800	0,84
460	56,2	1630	56	21,2	11,8	69,1	0,80	3750	29,7	16,5	96,7	2650	0,88
460	66,8	1950	54	24,8	13,8	67,7	0,80	4700	34,8	19,3	94,8	3300	0,87
460	96,7	2860	41	30,8	17,2	57,6	0,79	6600	43,1	24,1	80,6	4650	0,89
460	123,8	3680	34	36,0	19,8	51,3	0,78	8100	50,4	27,7	71,9	5700	0,89

Note: Speed values must be technically compatible with bearings type and applied accessories

Other windings on request

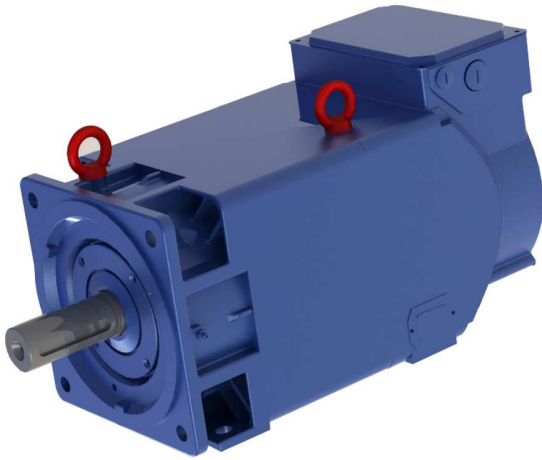

IP PROTECTION	IP54
THERMAL PROTECTION TYPE	KLIXON (PT100, PTC on request)
BALANCING, VIBRATION GRADE (EN 60034-14 / VDE 0530 part 14)	A (B on request)
INSULATION CLASS	F
COOLING METHOD	IC416A
STANDARD FAN DETAILS	3x400Vac 50/60Hz 0,18/0,22A
Amb. Cond.	0 + 40°C (32 + 104°F) 1000m ASL
TRANSDUCER	ENCODER OR RESOLVER (on request)
MOUNTING FORM	B3, B35, or other on request
BRAKE	up to 300 Nm (on request)
DE BEARING	BALL (ROLLER on request)
NDE BEARING	BALL
MAX MECHANICAL SPEED	6500 r.p.m. (4000 r.p.m. roller bearing) 10000 r.p.m. (S4 version)
PAINTING SYSTEM	NITRO, POLYURETHANIC, C5M, on request

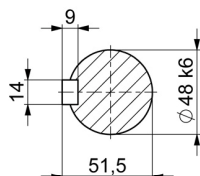
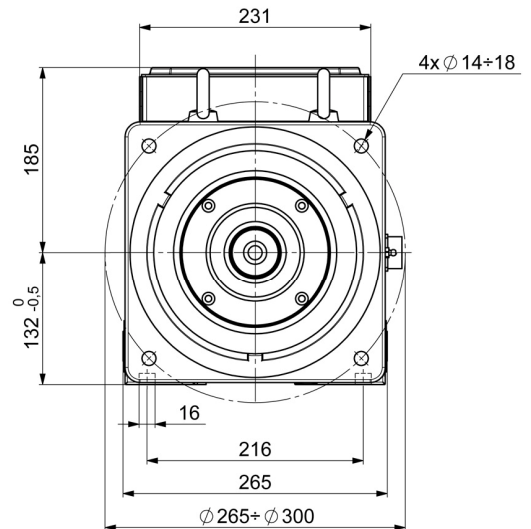
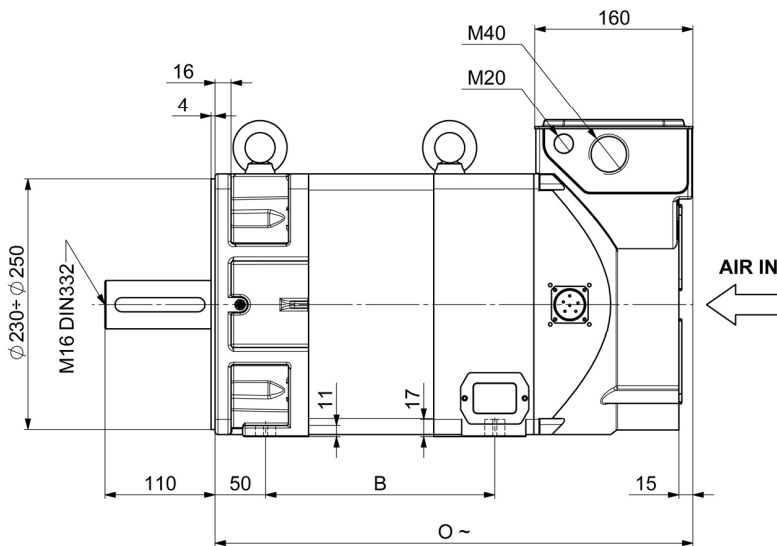

Ø42 OPTION

VARIABLES DIMENSIONS BY SIZE

SIZE	B	O
132K.1	227	480
132K.2	272	525
132K.3	307	560
132K.4	377	630
132K.5	447	700

unit [mm]

DRIVE AX 132K.1

S4 VERSION POWER DERATING: -5%

Tmax/Tn=3.3		J=0.042Kgm ²		S1					S6/40%				
Poles: 4													
VOLT	HZ	RPM	slip	L _{arm}	KW	Nm	cosφ	const. power RPM	L _{arm}	KW	Nm	const. power RPM	Eff. S1
380	35,4	1030	32	17,0	8,0	74,2	0,81	1800	23,8	11,2	103,9	1300	0,88
320	35,4	1030	32	20,1	8,0	74,2	0,81	1800	28,1	11,2	103,9	1300	0,88
380	53,4	1570	32	23,7	11,5	70,0	0,83	2850	33,2	16,1	97,9	2000	0,89
322	53,4	1570	32	27,8	11,5	70,0	0,83	2850	38,9	16,1	97,9	2000	0,89
380	71,0	2100	30	30,6	15,0	68,2	0,83	3800	42,8	21,0	95,5	2700	0,90
342	71,0	2100	30	34,0	15,0	68,2	0,83	3800	47,6	21,0	95,5	2700	0,90
380	88,5	2630	25	35,5	17,0	61,7	0,82	4500	49,7	23,8	86,4	3150	0,89
325	88,5	2630	25	41,5	17,0	61,7	0,82	4500	58,1	23,8	86,4	3150	0,89
380	109,0	3250	20	39,0	19,0	55,8	0,83	5550	54,6	26,6	78,2	3900	0,89
317	109,0	3250	20	47,0	19,0	55,8	0,83	5550	65,8	26,6	78,2	3900	0,89
380	138,0	4110	30	45,0	22,0	51,1	0,83	7000	63,0	30,8	71,6	4900	0,90
342	138,0	4110	30	50,0	22,0	51,1	0,83	7000	70,0	30,8	71,6	4900	0,90

Tmax/Tn=3.3		J=0.042Kgm ²		S1					S6/40%				
Poles: 4													
VOLT	HZ	RPM	slip	L _{arm}	KW	Nm	cosφ	const. power RPM	L _{arm}	KW	Nm	const. power RPM	Eff. S1
400	37,3	1090	28	17,0	8,0	74,2	0,81	1900	23,8	12,0	103,9	1368	0,88
400	56,2	1650	36	23,7	12,0	70,0	0,83	3000	33,2	17,0	97,9	2105	0,89
400	74,7	2210	32	30,6	16,0	68,2	0,83	4000	42,8	22,0	95,5	2842	0,90
400	114,7	3420	22	39,0	20,0	55,8	0,83	5850	54,6	28,0	78,2	4105	0,89
400	145,3	4330	28	45,0	23,0	51,1	0,83	7350	63,0	32,0	71,6	5158	0,90

Tmax/Tn=3.3		J=0.042Kgm ²		S1					S6/40%				
Poles: 4													
VOLT	HZ	RPM	slip	L _{arm}	KW	Nm	cosφ	const. power RPM	L _{arm}	KW	Nm	const. power RPM	Eff. S1
460	35,4	1030	32	14,1	8,0	74,2	0,81	1800	19,7	11,2	103,9	1300	0,88
460	52,5	1540	35	19,2	11,3	70,1	0,83	2800	26,9	15,8	98,1	2000	0,89
460	71,5	2110	35	25,2	15,0	67,9	0,83	3800	35,3	21,0	95,1	2700	0,90
460	88,8	2630	34	28,9	17,0	61,7	0,82	4500	40,5	23,8	86,4	3150	0,90
460	115,0	3420	30	33,6	20,0	55,9	0,83	5850	47,1	28,0	78,2	4100	0,90
460	139,1	4150	23	37,3	22,2	51,1	0,83	7100	52,3	31,1	71,5	5000	0,90

Note: Speed values must be technically compatible with bearings type and applied accessories

DRIVE AX 132K.2

S4 VERSION POWER DERATING: -5%

Tmax/Tn=3.3		J=0.056Kgm ²		S1					S6/40%				
Poles: 4													
VOLT	HZ	RPM	slip	L _{arm}	KW	Nm	cosφ	const. power RPM	L _{arm}	KW	Nm	const. power RPM	Eff. S1
380	35,3	1030	29	22,0	11,0	102,0	0,85	2000	30,8	15,4	142,8	1400	0,89
325	35,3	1030	29	26,0	11,0	102,0	0,85	2000	36,4	15,4	142,8	1400	0,89
380	51,0	1500	30	31,0	15,0	95,5	0,84	2850	43,4	21,0	133,7	2000	0,88
342	51,0	1500	30	34,5	15,0	95,5	0,84	2850	48,3	21,0	133,7	2000	0,87
380	69,0	2040	30	41,0	20,0	93,6	0,83	4100	57,4	28,0	131,1	2900	0,89
322	69,0	2040	30	48,3	20,0	93,6	0,83	4100	67,6	28,0	131,1	2900	0,90
380	83,0	2460	30	46,0	22,5	87,4	0,81	4950	64,4	31,5	122,3	3500	0,92
311	83,0	2460	30	56,2	22,5	87,4	0,81	4950	78,7	31,5	122,3	3500	0,92
380	101,0	3000	30	51,0	25,0	79,6	0,83	6000	71,4	35,0	111,4	4200	0,90
346	101,0	3000	30	56,0	25,0	79,6	0,83	6000	78,4	35,0	111,4	4200	0,90
380	135,2	4030	26	61,0	30,0	71,1	0,83	7500	85,4	42,0	99,5	5250	0,90
330	135,2	4030	26	70,0	30,0	71,1	0,83	7500	98,0	42,0	99,5	5250	0,90

Tmax/Tn=3.3		J=0.056Kgm ²		S1					S6/40%				
Poles: 4													
VOLT	HZ	RPM	slip	L _{arm}	KW	Nm	cosφ	const. power RPM	L _{arm}	KW	Nm	const. power RPM	Eff. S1
400	37,2	1090	25	22,0	12,0	102,0	0,85	2100	30,8	16,0	142,8	1450	0,90
400	53,7	1580	31	31,0	16,0	95,5	0,84	3000	43,4	22,0	133,7	2100	0,88
400	72,6	2150	29	41,0	21,0	93,6	0,83	4300	57,4	30,0	131,1	3050	0,89
400	106,3	3160	29	51,0	26,0	79,6	0,83	6300	71,4	37,0	111,4	4400	0,90
400	142,3	4240	29	61,0	32,0	71,1	0,83	7900	85,4	44,0	99,5	5550	0,90

Tmax/Tn=3.3		J=0.056Kgm ²		S1					S6/40%				
Poles: 4													
VOLT	HZ	RPM	slip	L _{arm}	KW	Nm	cosφ	const. power RPM	L _{arm}	KW	Nm	const. power RPM	Eff. S1
460	35,2	1020	36	18,2	11,0	103,0	0,85	1950	25,4	15,4	144,2	1400	0,89
460	51,5	1510	35	25,2	15,0	94,9	0,84	2900	35,3	21,0	132,8	2050	0,89
460	69,8	2060	34	34,0	20,2	93,7	0,83	4150	47,6	28,3	131,1	2950	0,90
460	85,0	2520	30	39,2	23,0	87,2	0,81	5050	54,9	32,2	122,0	3550	0,91
460	105,7	3140	31	43,2	26,1	79,4	0,83	6300	60,5	36,5	111,1	4450	0,92
460	136,3	4060	29	50,0	30,2	71,0	0,83	7550	70,0	42,3	99,5	5300	0,92

Note: Speed values must be technically compatible with bearings type and applied accessories

DRIVE AX 132K.3

S4 VERSION POWER DERATING: -5%

Tmax/Tn=3.5		J=0.067Kgm ²		S1					S6/40%				
Poles: 4													
VOLT	HZ	RPM	slip	L _{arm}	KW	Nm	cosφ	const. power RPM	L _{arm}	KW	Nm	const. power RPM	Eff. S1
380	34,2	990	36	25,2	12,5	120,6	0,86	2000	35,3	17,5	168,8	1400	0,88
348	34,2	990	36	27,5	12,5	120,6	0,86	2000	38,5	17,5	168,8	1400	0,88
380	53,0	1560	30	37,4	18,5	113,3	0,85	3600	52,4	25,9	158,6	2550	0,89
333	53,0	1560	30	42,7	18,5	113,3	0,85	3600	59,8	25,9	158,6	2550	0,89
380	72,0	2130	30	50,0	25,0	112,1	0,84	4900	70,0	35,0	156,9	3450	0,91
350	72,0	2130	30	54,3	25,0	112,1	0,84	4900	76,0	35,0	156,9	3450	0,91
380	87,5	2600	25	57,5	28,0	102,9	0,82	5750	80,5	39,2	144,0	4050	0,91
342	87,5	2600	25	63,9	28,0	102,9	0,82	5750	89,5	39,2	144,0	4050	0,91
380	102,9	3060	27	60,5	30,0	93,6	0,83	6750	84,7	42,0	131,1	4750	0,91
338	102,9	3060	27	68,0	30,0	93,6	0,83	6750	95,2	42,0	131,1	4750	0,91
380	128,5	3830	25	69,0	34,0	84,8	0,83	7500	96,6	47,6	118,7	5250	0,90
322	128,5	3830	25	81,5	34,0	84,8	0,83	7500	114,1	47,6	118,7	5250	0,90

Tmax/Tn=3.5		J=0.067Kgm ²		S1					S6/40%				
Poles: 4													
VOLT	HZ	RPM	slip	L _{arm}	KW	Nm	cosφ	const. power RPM	L _{arm}	KW	Nm	const. power RPM	Eff. S1
400	36,0	1040	40	25,2	13,0	120,6	0,86	2100	35,3	18,0	168,8	1450	0,88
400	55,8	1640	34	37,4	19,0	113,3	0,85	3800	52,4	27,0	158,6	2700	0,89
400	75,8	2240	34	50,0	26,0	112,1	0,84	5150	70,0	37,0	156,9	3650	0,91
400	108,3	3220	29	60,5	32,0	93,6	0,83	7100	84,7	44,0	131,1	5000	0,91
400	135,3	4030	28	69,0	36,0	84,8	0,83	7900	96,6	50,0	118,7	5550	0,90

Tmax/Tn=3.5		J=0.067Kgm ²		S1					S6/40%				
Poles: 4													
VOLT	HZ	RPM	slip	L _{arm}	KW	Nm	cosφ	const. power RPM	L _{arm}	KW	Nm	const. power RPM	Eff. S1
460	35,5	1030	34	21,7	13,0	120,6	0,86	2100	30,3	18,2	168,8	1500	0,88
460	51,5	1510	35	30,1	18,0	113,9	0,85	3500	42,1	25,2	159,4	2450	0,89
460	74,8	2210	34	43,0	26,0	112,4	0,84	5100	60,1	36,4	157,3	3600	0,91
460	88,2	2610	36	47,5	28,0	102,5	0,82	5750	66,5	39,2	143,4	4050	0,91
460	102,0	3030	30	50,0	30,0	94,6	0,83	6700	70,0	42,0	132,4	4700	0,91
460	129,9	3870	27	57,0	34,0	83,9	0,83	7550	79,8	47,6	117,5	5300	0,90

Note: Speed values must be technically compatible with bearings type and applied accessories

DRIVE AX 132K.4

S4 VERSION POWER DERATING: -5%

Tmax/Tn=3.5		J=0.104Kgm ²		S1					S6/40%				
Poles: 4													
VOLT	HZ	RPM	slip	L _{arm}	KW	Nm	cosφ	const. power RPM	L _{arm}	KW	Nm	const. power RPM	Eff. S1
380	34,0	990	30	32,0	16,0	154,4	0,86	2400	44,8	22,4	216,1	1700	0,88
340	34,0	990	30	35,8	16,0	154,4	0,86	2400	50,1	22,4	216,1	1700	0,88
380	52,3	1540	29	48,0	24,0	148,8	0,86	3700	67,2	33,6	208,4	2600	0,89
348	52,3	1540	29	52,3	24,0	148,8	0,86	3700	73,2	33,6	208,4	2600	0,89
380	70,8	2100	24	64,0	32,0	145,5	0,85	4850	89,6	44,8	203,8	3400	0,89
338	70,8	2100	24	72,0	32,0	145,5	0,85	4850	100,8	44,8	203,8	3400	0,89
380	82,5	2450	25	70,0	35,0	136,4	0,83	5400	98,0	49,0	191,0	3800	0,92
330	82,5	2450	25	80,5	35,0	136,4	0,83	5400	112,7	49,0	191,0	3800	0,92
380	99,5	2960	25	76,0	38,0	122,6	0,84	6250	106,4	53,2	171,7	4400	0,91
348	99,5	2960	25	83,0	38,0	122,6	0,84	6250	116,2	53,2	171,7	4400	0,91
380	123,0	3670	20	90,0	45,0	117,1	0,84	7000	126,0	63,0	164,0	4900	0,91
342	123,0	3670	20	100,0	45,0	117,1	0,84	7000	140,0	63,0	164,0	4900	0,91

Tmax/Tn=3.5		J=0.104Kgm ²		S1					S6/40%				
Poles: 4													
VOLT	HZ	RPM	slip	L _{arm}	KW	Nm	cosφ	const. power RPM	L _{arm}	KW	Nm	const. power RPM	Eff. S1
400	35,8	1040	34	32,0	17,0	154,4	0,86	2550	44,8	24,0	216,1	1800	0,88
400	55,1	1620	32	48,0	25,0	148,8	0,86	3900	67,2	35,0	208,4	2750	0,89
400	74,5	2210	26	64,0	34,0	145,5	0,85	5100	89,6	47,0	203,8	3600	0,90
400	104,7	3120	22	76,0	40,0	122,6	0,84	6600	106,4	56,0	171,7	4650	0,91
400	129,5	3860	24	90,0	47,0	117,1	0,84	7350	126,0	66,0	164,0	5150	0,91

Tmax/Tn=3.5		J=0.104Kgm ²		S1					S6/40%				
Poles: 4													
VOLT	HZ	RPM	slip	L _{arm}	KW	Nm	cosφ	const. power RPM	L _{arm}	KW	Nm	const. power RPM	Eff. S1
460	33,6	970	38	25,7	15,6	153,6	0,86	2350	35,9	21,8	215,0	1650	0,89
460	54,3	1590	39	41,0	24,8	149,0	0,86	3850	57,3	34,7	208,6	2700	0,89
460	70,2	2070	36	51,7	31,5	145,3	0,85	4800	72,4	44,1	203,5	3400	0,90
460	88,7	2630	31	62,4	37,5	136,2	0,83	5800	87,3	52,5	190,7	4100	0,91
460	104,4	3100	32	59,9	36,2	111,5	0,84	6550	83,8	50,7	156,1	4600	0,91
460	124,1	3690	33	74,0	45,0	116,5	0,84	7050	103,6	63,0	163,1	4950	0,91

Note: Speed values must be technically compatible with bearings type and applied accessories

DRIVE AX 132K.5

S4 VERSION POWER DERATING: -5%

Tmax/Tn=3.5		J=0.130Kgm ²		S1					S6/40%				
Poles: 4													
VOLT	HZ	RPM	slip	L _{arm}	KW	Nm	cosφ	const. power RPM	L _{arm}	KW	Nm	const. power RPM	Eff. S1
380	34,8	1010	34	42,0	21,0	198,6	0,86	2450	58,8	29,4	278,0	1750	0,88
326	34,8	1010	34	49,0	21,0	198,6	0,86	2450	68,6	29,4	278,0	1750	0,88
380	55,6	1640	28	65,0	32,5	189,3	0,86	3800	91,0	45,5	265,0	2700	0,89
338	55,6	1640	28	73,0	32,5	189,3	0,86	3800	102,2	45,5	265,0	2700	0,89
380	67,6	2000	28	80,0	40,0	191,0	0,85	4400	112,0	56,0	267,4	3100	0,89
321	67,6	2000	28	95,0	40,0	191,0	0,85	4400	133,0	56,0	267,4	3100	0,89
380	89,4	2660	22	96,0	47,0	168,8	0,82	5750	134,4	65,8	236,3	4050	0,91
342	89,4	2660	22	106,7	47,0	168,8	0,82	5750	149,4	65,8	236,3	4050	0,91
380	105,8	3150	24	100,0	50,0	151,6	0,84	6500	140,0	70,0	212,2	4550	0,91
338	105,8	3150	24	112,4	50,0	151,6	0,84	6500	157,4	70,0	212,2	4550	0,91
380	122,0	3640	20	106,0	53,0	139,1	0,84	7000	148,4	74,2	194,7	4900	0,91
332	122,0	3640	20	121,5	53,0	139,1	0,84	7000	170,1	74,2	194,7	4900	0,90

Tmax/Tn=3.5		J=0.130Kgm ²		S1					S6/40%				
Poles: 4													
VOLT	HZ	RPM	slip	L _{arm}	KW	Nm	cosφ	const. power RPM	L _{arm}	KW	Nm	const. power RPM	Eff. S1
400	36,6	1065	34	42,0	22,0	198,6	0,86	2600	58,8	31,0	278,0	1850	0,88
400	58,5	1730	26	65,0	34,0	189,3	0,86	4000	91,0	48,0	265,0	2850	0,89
400	71,2	2110	25	80,0	42,0	191,0	0,85	4650	112,0	59,0	267,4	3250	0,90
400	111,4	3320	21	100,0	53,0	151,6	0,84	6850	140,0	74,0	212,2	4800	0,91
400	128,4	3830	23	106,0	56,0	139,1	0,84	7350	148,4	78,0	194,7	5150	0,91

Tmax/Tn=3.5		J=0.130Kgm ²		S1					S6/40%				
Poles: 4													
VOLT	HZ	RPM	slip	L _{arm}	KW	Nm	cosφ	const. power RPM	L _{arm}	KW	Nm	const. power RPM	Eff. S1
460	34,6	1000	38	34,5	21,0	200,6	0,86	2400	48,3	29,4	280,8	1700	0,89
460	55,1	1620	33	53,7	32,5	191,6	0,86	3750	75,1	45,5	268,3	2650	0,89
460	68,4	2020	32	65,7	40,0	189,1	0,85	4450	92,0	56,0	264,8	3150	0,90
460	90,4	2680	32	80,0	47,0	167,5	0,82	5800	112,0	65,8	234,5	4100	0,90
460	104,8	3110	34	82,2	50,0	153,6	0,84	6400	115,1	70,0	215,0	4500	0,91
460	118,0	3510	30	87,1	53,0	144,2	0,84	6750	122,0	74,2	201,9	4750	0,91

Note: Speed values must be technically compatible with bearings type and applied accessories
Other windings on request



IP PROTECTION	IP54
THERMAL PROTECTION TYPE	KLIXON (PT100, PTC on request)
BALANCING, VIBRATION GRADE (EN 60034-14 / VDE 0530 part 14)	A (B on request)
INSULATION CLASS	F
COOLING METHOD	IC416A
STANDARD FAN DETAILS	3x400Vac 50/60Hz 0,26/0,33A
Amb. Cond.	0 + 40°C (32 + 104°F) 1000m ASL
TRANSDUCER	ENCODER OR RESOLVER (on request)
MOUNTING FORM	B3, B35, or other on request
BRAKE	up to 400 Nm (on request)
DE BEARING	BALL, ROLLER or INSULATED on request
NDE BEARING	BALL (insulated on request)
MAX MECHANICAL SPEED	5500 r.p.m. (3500 r.p.m. roller bearing) 8000 r.p.m. (S4 version)
PAINTING SYSTEM	NITRO, POLYURETHANIC, C5M, on request

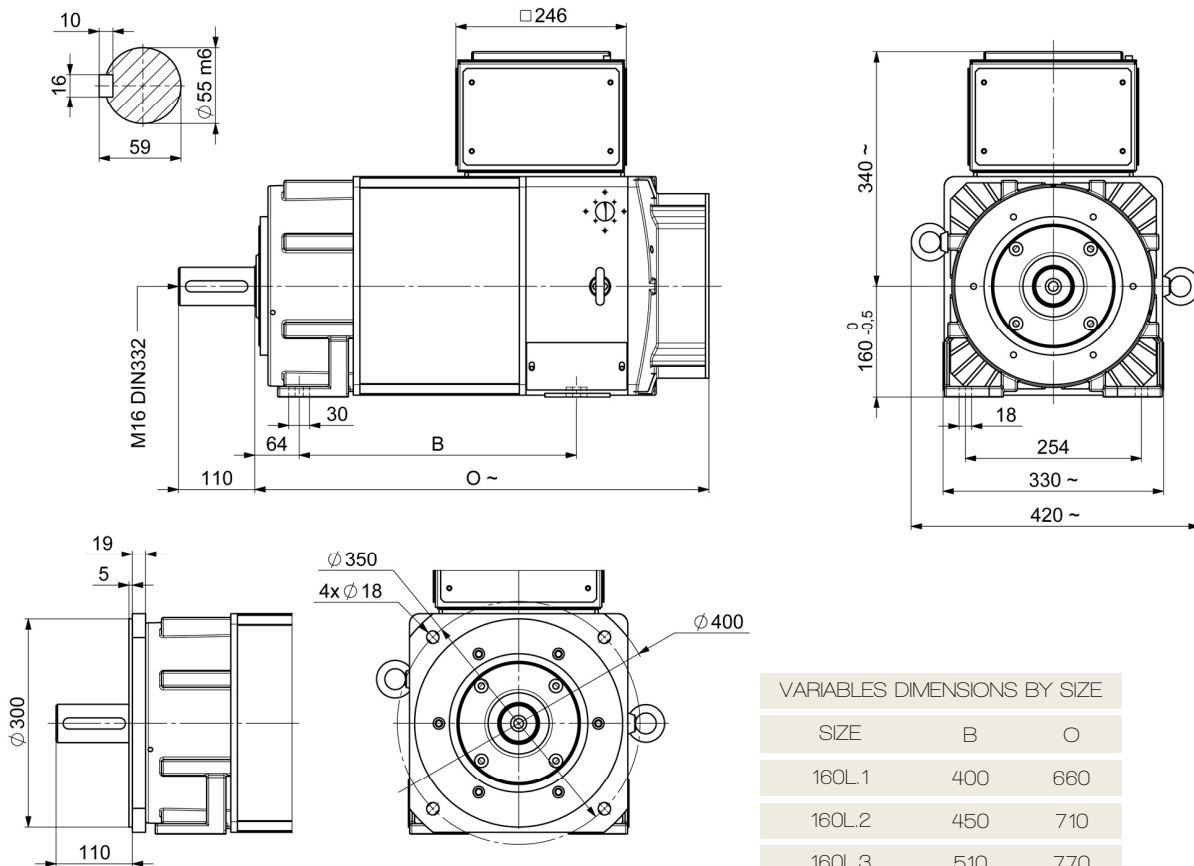

VARIABLES DIMENSIONS BY SIZE		
SIZE	B	O
160L.1	400	660
160L.2	450	710
160L.3	510	770
160L.4	570	830
160L.5	620	880

unit [mm]

DRIVE AX 160L.1

S4 VERSION POWER DERATING: -5% (Tmax/Tn=2.9)

Tmax/Tn=3.5		J=0.21Kgm ²		S1					S6/40%				
Poles: 4													
VOLT	HZ	RPM	slip	L _{arm}	KW	Nm	cosφ	const. power max RPM	L _{arm}	KW	Nm	const. power max RPM	Eff. S1
380	29,5	850	35	38,5	18,5	207,9	0,83	1700	53,9	25,9	291,0	1200	0,88
345	29,5	850	35	42,0	18,5	207,9	0,83	1700	58,8	25,9	291,0	1200	0,88
380	41,0	1200	30	50,5	25,0	199,0	0,83	2550	70,7	35,0	278,6	1800	0,91
332	41,0	1200	30	58,0	25,0	199,0	0,83	2550	81,2	35,0	278,6	1800	0,91
380	51,0	1500	30	60,5	30,0	191,0	0,82	3150	84,7	42,0	267,4	2250	0,92
320	51,0	1500	30	72,0	30,0	191,0	0,82	3150	100,8	42,0	267,4	2250	0,91
380	84,5	2500	35	85,4	40,0	152,8	0,77	5000	119,6	56,0	213,9	3500	0,93
332	84,5	2500	35	98,0	40,0	152,8	0,77	5000	137,2	56,0	213,9	3500	0,93
380	101,0	3000	30	96,7	46,0	146,5	0,78	6000	135,4	64,4	205,0	4200	0,93
345	101,0	3000	30	106,5	46,0	146,5	0,78	6000	149,1	64,4	205,0	4200	0,93

Tmax/Tn=3.5		J=0.21Kgm ²		S1					S6/40%				
Poles: 4													
VOLT	HZ	RPM	slip	L _{arm}	KW	Nm	cosφ	const. power max RPM	L _{arm}	KW	Nm	const. power max RPM	Eff. S1
400	31,1	900	32	38,5	20	207,9	0,83	1800	53,9	27	291,0	1250	0,88
400	43,2	1260	35	50,5	26	199,0	0,83	2700	70,7	37	278,6	1900	0,91
400	53,7	1580	31	60,5	32	191,0	0,82	3300	84,7	44	267,4	2350	0,92
400	88,9	2630	38	85,4	42	152,8	0,77	5250	119,6	59	213,9	3700	0,93
400	106,3	3160	29	96,7	48	146,5	0,78	6300	135,4	68	205,0	4400	0,93

Tmax/Tn=3.5		J=0.21Kgm ²		S1					S6/40%				
Poles: 4													
VOLT	HZ	RPM	slip	L _{arm}	KW	Nm	cosφ	const. power max RPM	L _{arm}	KW	Nm	const. power max RPM	Eff. S1
460	30,3	875	34	32,7	19,0	207,4	0,83	1750	45,7	26,6	290,4	1250	0,88
460	39,8	1160	34	40,4	24,2	199,3	0,83	2450	56,5	33,9	279,0	1750	0,91
460	50,3	1480	29	50,0	30,0	193,6	0,82	3150	70,0	42,0	271,0	2250	0,92
460	81,8	2420	34	68,3	38,7	152,7	0,77	4850	95,6	54,2	213,8	3400	0,93
460	107,0	3180	30	84,2	48,5	145,7	0,78	6400	117,9	67,9	203,9	4500	0,93

Note: Speed values must be technically compatible with bearings type and applied accessories

DRIVE AX 160L.2

S4 VERSION POWER DERATING: -5% (Tmax/Tn=2.7)

Tmax/Tn=3.5		J=0.25Kgm ²		S1					S6/40%				
Poles: 4													
VOLT	HZ	RPM	slip	L _{arm}	KW	Nm	cosφ	const. power max RPM	L _{arm}	KW	Nm	const. power max RPM	Eff. S1
380	27,0	780	30	42,5	21,0	257,1	0,85	1650	59,5	29,4	360,0	1200	0,88
340	27,0	780	30	47,5	21,0	257,1	0,85	1650	66,5	29,4	360,0	1200	0,88
380	39,0	1150	20	59,5	30,0	249,2	0,85	2450	83,3	42,0	348,8	1750	0,91
325	39,0	1150	20	69,5	30,0	249,2	0,85	2450	97,3	42,0	348,8	1750	0,91
380	51,0	1500	30	73,0	37,0	235,6	0,84	3300	102,2	51,8	329,8	2400	0,92
345	51,0	1500	30	80,5	37,0	235,6	0,84	3300	112,7	51,8	329,8	2400	0,92
380	81,0	2400	30	103,0	50,0	199,0	0,80	5050	144,2	70,0	278,6	3600	0,92
315	81,0	2400	30	124,0	50,0	199,0	0,80	5050	173,6	70,0	278,6	3600	0,92
380	101,0	3000	30	117,0	56,0	178,3	0,79	6000	163,8	78,4	249,6	4200	0,93
342	101,0	3000	30	130,0	56,0	178,3	0,79	6000	182,0	78,4	249,6	4200	0,93

Tmax/Tn=3.5		J=0.25Kgm ²		S1					S6/40%				
Poles: 4													
VOLT	HZ	RPM	slip	L _{arm}	KW	Nm	cosφ	const. power max RPM	L _{arm}	KW	Nm	const. power max RPM	Eff. S1
400	28,4	820	33	42,5	22	257,1	0,85	1750	59,5	31	360,0	1250	0,88
400	41,1	1210	22	59,5	32	249,2	0,85	2600	83,3	44	348,8	1850	0,91
400	53,7	1580	31	73,0	39	235,6	0,84	3450	102,2	55	329,8	2550	0,92
400	85,3	2530	28	103,0	53	199,0	0,80	5300	144,2	74	278,6	3800	0,92
400	106,3	3160	29	117,0	59	178,3	0,79	6300	163,8	83	249,6	4400	0,93

Tmax/Tn=3.5		J=0.25Kgm ²		S1					S6/40%				
Poles: 4													
VOLT	HZ	RPM	slip	L _{arm}	KW	Nm	cosφ	const. power max RPM	L _{arm}	KW	Nm	const. power max RPM	Eff. S1
460	27,3	790	29	35,1	21,0	253,9	0,85	1700	49,2	29,4	355,4	1200	0,88
460	41,3	1210	29	51,6	31,5	248,6	0,85	2550	72,3	44,1	348,1	1850	0,91
460	52,0	1530	30	61,1	37,5	234,1	0,84	3400	85,6	52,5	327,7	2450	0,92
460	85,5	2535	30	89,3	52,5	197,8	0,80	5350	125,1	73,5	276,9	3850	0,92
460	102,0	3030	30	97,5	56,5	178,1	0,79	6100	136,5	79,1	249,3	4250	0,93

Note: Speed values must be technically compatible with bearings type and applied accessories

DRIVE AX 160L.3

S4 VERSION POWER DERATING: -5% (Tmax/Tn=2.4)

Tmax/Tn=3.5		J=0.31Kgm ²		S1					S6/40%				
Poles: 4													
VOLT	HZ	RPM	slip	L _{arm}	KW	Nm	cosφ	const. power max RPM	L _{arm}	KW	Nm	const. power max RPM	Eff. S1
380	27,5	800	25	53,0	26,0	310,4	0,84	1800	74,2	36,4	434,6	1300	0,89
332	27,5	800	25	61,0	26,0	310,4	0,84	1800	85,4	36,4	434,6	1300	0,88
380	41,0	1200	30	73,5	37,0	294,5	0,84	2650	102,9	51,8	412,3	1950	0,92
345	41,0	1200	30	81,0	37,0	294,5	0,84	2650	113,4	51,8	412,3	1950	0,92
380	51,0	1500	30	89,0	45,0	286,5	0,84	3600	124,6	63,0	401,1	2700	0,92
340	51,0	1500	30	99,3	45,0	286,5	0,84	3600	139,0	63,0	401,1	2700	0,92
380	80,7	2400	21	125,0	60,0	238,8	0,79	5550	175,0	84,0	334,3	3850	0,92
340	80,7	2400	21	139,0	60,0	238,8	0,79	5550	194,6	84,0	334,3	3850	0,93
380	104,0	3100	20	147,0	70,0	215,7	0,78	6400	205,8	98,0	301,9	4650	0,93
332	104,0	3100	20	168,0	70,0	215,7	0,78	6400	235,2	98,0	301,9	4650	0,93

Tmax/Tn=3.5		J=0.31Kgm ²		S1					S6/40%				
Poles: 4													
VOLT	HZ	RPM	slip	L _{arm}	KW	Nm	cosφ	const. power max RPM	L _{arm}	KW	Nm	const. power max RPM	Eff. S1
400	28,9	840	28	53,0	27	310,4	0,84	1900	74,2	38	434,6	1350	0,89
400	43,2	1260	35	73,5	39	294,5	0,84	2800	102,9	54	412,3	2050	0,92
400	53,7	1580	31	89,0	47	286,5	0,84	3800	124,6	66	401,1	2850	0,92
400	84,9	2530	18	125,0	63	238,8	0,79	5850	175,0	89	334,3	4050	0,92
400	109,5	3260	24	147,0	74	215,7	0,78	6750	205,8	103	301,9	4900	0,93

Tmax/Tn=3.5		J=0.31Kgm ²		S1					S6/40%				
Poles: 4													
VOLT	HZ	RPM	slip	L _{arm}	KW	Nm	cosφ	const. power max RPM	L _{arm}	KW	Nm	const. power max RPM	Eff. S1
460	26,6	770	28	42,1	25,0	310,1	0,84	1700	58,9	35,0	434,1	1250	0,89
460	41,9	1230	27	62,4	38,0	295,1	0,84	2750	87,3	53,2	413,1	2000	0,92
460	50,6	1490	28	73,5	45,0	288,5	0,84	3600	102,9	63,0	403,8	2700	0,92
460	81,2	2410	26	102,0	60,0	237,8	0,80	5550	142,8	84,0	332,9	3900	0,92
460	100,8	3000	24	114,7	67,8	215,9	0,80	6150	160,5	94,9	302,2	4500	0,93

Note: Speed values must be technically compatible with bearings type and applied accessories

DRIVE AX 160L.4

S4 VERSION POWER DERATING: -5% (Tmax/Tn=2.2)

Tmax/Tn=3.5		J=0.36Kgm ²		S1					S6/40%				
Poles: 4													
VOLT	HZ	RPM	slip	L _{arm}	KW	Nm	cosφ	const. power max RPM	L _{arm}	KW	Nm	const. power max RPM	Eff. S1
380	27,0	780	30	61,0	30,0	367,3	0,84	1800	85,4	42,0	514,3	1350	0,89
327	27,0	780	30	71,2	30,0	367,3	0,84	1800	99,7	42,0	514,3	1350	0,89
380	39,0	1150	20	84,0	42,0	348,8	0,84	2650	117,6	58,8	488,4	2000	0,91
342	39,0	1150	20	94,0	42,0	348,8	0,84	2650	131,6	58,8	488,4	2000	0,90
380	56,0	1650	30	115,0	57,0	329,9	0,82	4000	161,0	79,8	461,9	3000	0,92
345	56,0	1650	30	126,0	57,0	329,9	0,82	4000	176,4	79,8	461,9	3000	0,92
380	85,0	2520	30	152,0	73,0	276,7	0,79	6050	212,8	102,2	387,4	4550	0,92
330	85,0	2520	30	175,0	73,0	276,7	0,79	6050	245,0	102,2	387,4	4550	0,92
380	101,0	3000	30	168,0	80,0	254,7	0,78	6500	235,2	112,0	356,6	4950	0,93
325	101,0	3000	30	197,0	80,0	254,7	0,78	6500	275,8	112,0	356,6	4950	0,93

Tmax/Tn=3.5		J=0.36Kgm ²		S1					S6/40%				
Poles: 4													
VOLT	HZ	RPM	slip	L _{arm}	KW	Nm	cosφ	const. power max RPM	L _{arm}	KW	Nm	const. power max RPM	Eff. S1
400	28,4	820	33	61,0	32	367,3	0,84	1900	85,4	44	514,3	1400	0,89
400	41,1	1210	22	84,0	44	348,8	0,84	2800	117,6	62	488,4	2100	0,91
400	58,9	1740	28	115,0	60	329,9	0,82	4200	161,0	84	461,9	3150	0,92
400	89,5	2650	34	152,0	77	276,7	0,79	6350	212,8	107	387,4	4800	0,92
400	106,3	3160	29	168,0	84	254,7	0,78	6850	235,2	118	356,6	5200	0,93

Tmax/Tn=3.5		J=0.36Kgm ²		S1					S6/40%				
Poles: 4													
VOLT	HZ	RPM	slip	L _{arm}	KW	Nm	cosφ	const. power max RPM	L _{arm}	KW	Nm	const. power max RPM	Eff. S1
460	28,6	830	28	53,8	32,0	368,2	0,84	1950	75,3	44,8	515,5	1450	0,89
460	39,4	1150	32	69,4	42,0	348,8	0,84	2650	97,1	58,8	488,4	2000	0,91
460	59,2	1750	26	100,0	60,0	327,5	0,82	4200	140,0	84,0	458,5	3150	0,92
460	81,8	2430	24	119,7	70,5	277,1	0,80	5850	167,6	98,7	387,9	4400	0,92
460	107,0	3190	20	142,1	84,0	251,5	0,80	6500	198,9	117,6	352,1	5150	0,93

Note: Speed values must be technically compatible with bearings type and applied accessories

DRIVE AX 160L.5

NOT AVAILABLE IN S4 VERSION

Tmax/Tn=3.5		J=0.40Kgm ²		S1					S6/40%				
Poles: 4													
VOLT	HZ	RPM	slip	L _{arm}	KW	Nm	cosφ	const. power max RPM	L _{arm}	KW	Nm	const. power max RPM	Eff. S1
380	28,0	810	30	71,0	35,0	412,7	0,84	1900	99,4	49,0	577,8	1400	0,89
317	28,0	810	30	85,0	35,0	412,7	0,84	1900	119,0	49,0	577,8	1400	0,89
380	34,7	1010	31	84,0	41,5	392,4	0,84	2350	117,6	58,1	549,4	1750	0,89
342	34,7	1010	31	94,0	41,5	392,4	0,84	2350	131,6	58,1	549,4	1750	0,89
380	46,3	1360	29	115,0	55,0	386,3	0,84	3300	161,0	77,0	540,8	2550	0,87
351	46,3	1360	29	126,0	55,0	386,3	0,84	3300	176,4	77,0	540,8	2550	0,86
380	54,7	1610	31	125,0	62,0	367,8	0,83	3950	175,0	86,8	514,9	3000	0,91
346	54,7	1610	31	137,0	62,0	367,8	0,83	3950	191,8	86,8	514,9	3000	0,92
380	76,0	2250	30	154,5	74,0	314,1	0,79	5550	216,3	103,6	439,8	4200	0,92
336	76,0	2250	30	175,0	74,0	314,1	0,79	5550	245,0	103,6	439,8	4200	0,92
380	86,9	2580	27	171,0	82,0	303,6	0,79	6350	239,4	114,8	425,0	4800	0,92
326	86,9	2580	27	199,0	82,0	303,6	0,79	6350	278,6	114,8	425,0	4800	0,92

Tmax/Tn=3.5		J=0.40Kgm ²		S1					S6/40%				
Poles: 4													
VOLT	HZ	RPM	slip	L _{arm}	KW	Nm	cosφ	const. power max RPM	L _{arm}	KW	Nm	const. power max RPM	Eff. S1
400	29,4	850	32	71,0	37	413	0,84	2000	99,4	51	577,8	1450	0,89
400	36,5	1060	35	84,0	44	396	0,84	2450	117,6	60	540,0	1850	0,89
400	57,6	1700	28	125,0	65	368	0,83	4200	175,0	92	514,9	3150	0,92
400	80,0	2370	30	154,5	78	314	0,79	5850	216,3	109	439,8	4400	0,92
400	91,5	2720	25	171,0	86	304	0,79	6700	239,4	121	425,0	5050	0,92

Tmax/Tn=3.5		J=0.40Kgm ²		S1					S6/40%				
Poles: 4													
VOLT	HZ	RPM	slip	L _{arm}	KW	Nm	cosφ	const. power max RPM	L _{arm}	KW	Nm	const. power max RPM	Eff. S1
460	29,1	840	33	61,0	36,3	412,7	0,84	1950	85,4	50,8	577,8	1450	0,89
460	38,2	1110	36	75,0	45,6	392,4	0,84	2600	104,9	63,8	549,3	1900	0,91
460	60,0	1770	30	113,1	68,0	366,9	0,82	4250	158,4	95,2	513,7	3200	0,92
460	80,9	2400	27	131,3	77,5	308,4	0,80	5800	183,8	108,5	431,8	4350	0,93
460	95,2	2830	26	148,8	87,0	293,6	0,79	5750	208,3	121,8	411,1	4550	0,93

Note: Speed values must be technically compatible with bearings type and applied accessories

Other windings on request

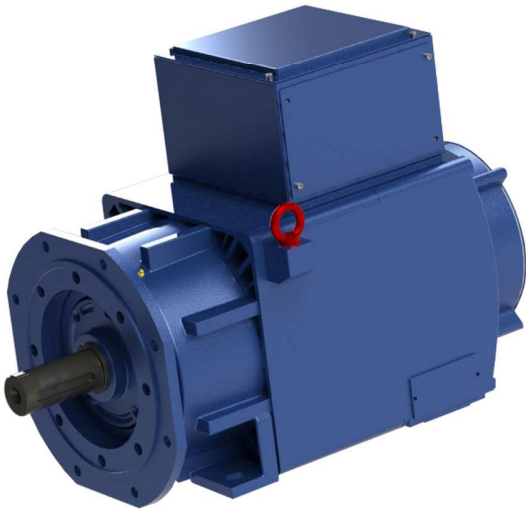

IP PROTECTION	IP54
THERMAL PROTECTION TYPE	KLIXON (PT100, PTC on request)
BALANCING, VIBRATION GRADE (EN 60034-14 / VDE 0530 part 14)	A (B on request)
INSULATION CLASS	F
COOLING METHOD	IC416A
STANDARD FAN DETAILS	3x400Vac 50/60Hz 0,43/0,58A
Amb. Cond.	0 + 40°C (32 + 104°F) 1000m ASL
TRANSDUCER	ENCODER OR RESOLVER (on request)
MOUNTING FORM	B3, B35, or other on request
BRAKE	up to 600 Nm (on request)
DE BEARING	BALL, ROLLER or INSULATED on request
NDE BEARING	BALL (insulated on request)
MAX MECHANICAL SPEED	4500 r.p.m. (3200 r.p.m. roller bearing) 6500 r.p.m. (S6 version)
PAINTING SYSTEM	NITRO, POLYURETHANIC, C5M, on request

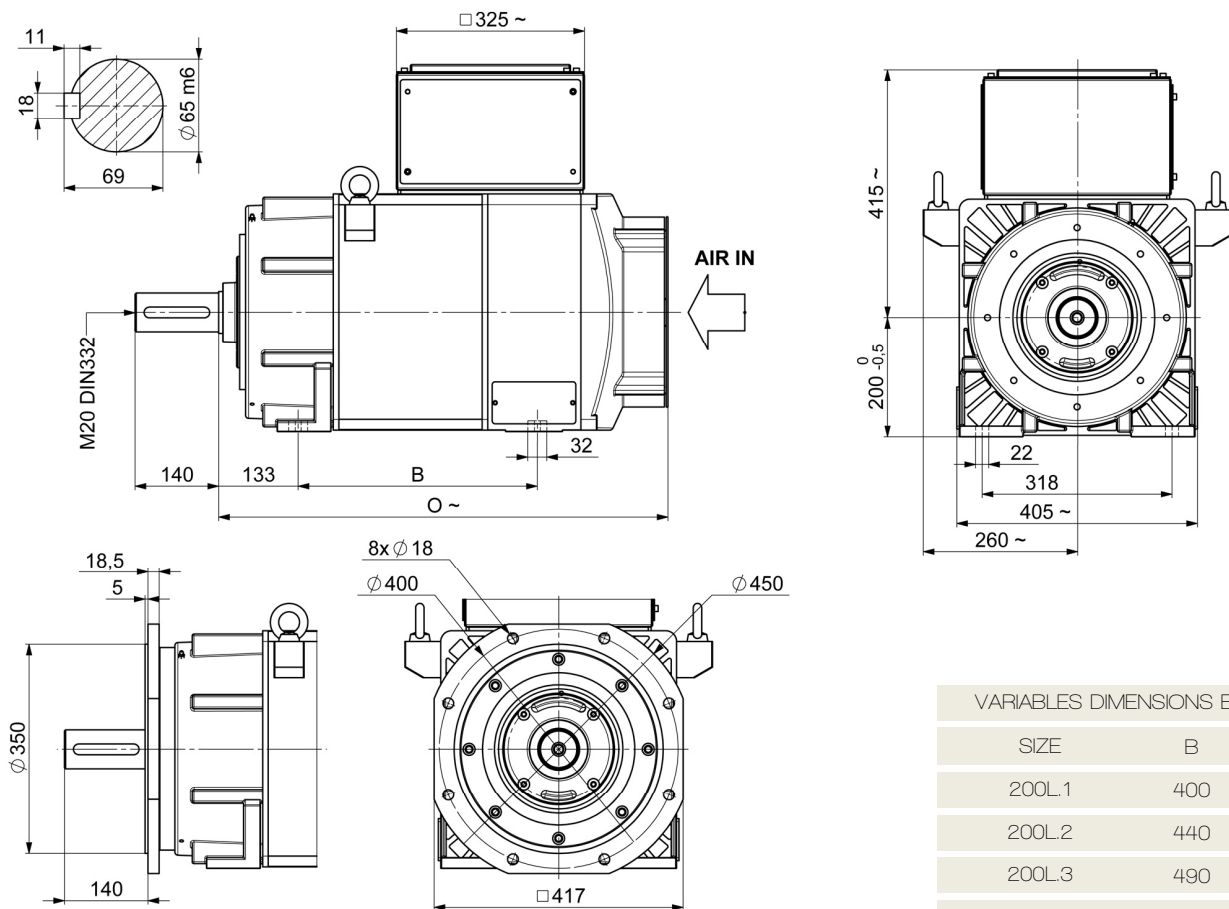

VARIABLES DIMENSIONS BY SIZE		
SIZE	B	O
200L.1	400	760
200L.2	440	800
200L.3	490	850
200L.4	560	920
200L.5	660	1020

unit [mm]

DRIVE AX 200L.1

S6 VERSION POWER DERATING: -5% (Tmax/Tn=3.3)

Tmax/Tn=3.3		J=0.55Kgm ²		S1					S6/40%				
Poles: 6													
VOLT	HZ	RPM	slip	L _{arm}	KW	Nm	cosφ	const. power max RPM	L _{arm}	KW	Nm	const. power max RPM	Eff. S1
380	39,7	770	24	63,0	30	372,1	0,82	1550	88,2	42,0	521,0	1100	0,88
331	39,7	770	24	72,5	30	372,1	0,82	1550	101,5	42,0	521,0	1100	0,88
380	65,5	1290	20	96,0	47	348,0	0,82	2750	134,4	65,8	487,2	1950	0,91
333	65,5	1290	20	110,0	47	348,0	0,82	2750	154,0	65,8	487,2	1950	0,90
380	84,0	1660	20	118,0	58	333,7	0,81	3500	165,2	81,2	467,2	2500	0,92
311	84,0	1660	20	144,0	58	333,7	0,81	3500	201,6	81,2	467,2	2500	0,92
380	122,0	2420	20	150,0	73	288,1	0,80	5000	210,0	102,2	403,4	3650	0,93
330	122,0	2420	20	172,0	73	288,1	0,80	5000	240,8	102,2	403,4	3650	0,93
380	164,5	3270	20	174,0	85	248,3	0,80	5600	243,6	119,0	347,6	4600	0,93
345	164,5	3270	20	192,0	85	248,3	0,80	5600	268,8	119,0	347,6	4600	0,93

Tmax/Tn=3.3		J=0.55Kgm ²		S1					S6/40%				
Poles: 6													
VOLT	HZ	RPM	slip	L _{arm}	KW	Nm	cosφ	const. power max RPM	L _{arm}	KW	Nm	const. power max RPM	Eff. S1
400	41,8	810	26	63,0	32	372,1	0,82	1650	88,2	44	521,0	1150	0,88
400	68,9	1360	19	96,0	50	348,0	0,82	2900	134,4	69	487,2	2050	0,91
400	88,4	1750	18	118,0	61	333,7	0,81	3700	165,2	86	467,2	2650	0,92
400	128,4	2550	18	150,0	77	288,1	0,80	5250	210,0	108	403,4	3850	0,93
400	173,2	3440	23	174,0	89	248,3	0,80	5250	243,6	125	347,6	4850	0,93

Tmax/Tn=3.3		J=0.55Kgm ²		S1					S6/40%				
Poles: 6													
VOLT	HZ	RPM	slip	L _{arm}	KW	Nm	cosφ	const. power max RPM	L _{arm}	KW	Nm	const. power max RPM	Eff. S1
460	40,1	780	22	52,0	30	367,3	0,82	1600	72,9	42,0	514,3	1100	0,88
460	63,5	1250	20	76,8	45,5	347,7	0,82	2650	107,5	63,7	486,7	1900	0,91
460	86,0	1700	20	99,2	59	331,5	0,81	3600	138,8	82,6	464,1	2550	0,92
460	118,2	2345	19	120,5	71	289,2	0,80	4850	168,7	99,4	404,9	3550	0,93
460	168,9	3360	18	146,2	87	247,3	0,80	5150	204,7	121,8	346,2	4750	0,93

Note: Speed values must be technically compatible with bearings type and applied accessories

DRIVE AX 200L.2

S6 VERSION POWER DERATING: -5% ($T_{max}/T_n=3.1$)

T _{max} /T _n =3.4		J=0.63Kgm ²		S1					S6/40%				
Poles: 6													
VOLT	HZ	RPM	slip	L _{arm}	KW	Nm	cosφ	const. power max RPM	L _{arm}	KW	Nm	const. power max RPM	Eff. S1
380	40,3	770	36	72,0	37	458,9	0,84	1650	100,8	51,8	642,5	1200	0,93
320	40,3	770	36	85,5	37	458,9	0,84	1650	119,7	51,8	642,5	1200	0,93
380	65,0	1280	20	107,0	54	402,9	0,83	2850	149,8	75,6	564,1	1950	0,92
317	65,0	1280	20	128,5	54	402,9	0,83	2850	179,9	75,6	564,1	1950	0,92
380	79,0	1560	20	129,0	66	404,1	0,83	3450	180,6	92,4	565,7	2350	0,94
342	79,0	1560	20	143,0	66	404,1	0,83	3450	200,2	92,4	565,7	2350	0,94
380	105,0	2080	20	156,0	77	353,6	0,81	4600	218,4	107,8	495,0	3150	0,93
331	105,0	2080	20	180,0	77	353,6	0,81	4600	252,0	107,8	495,0	3150	0,92
380	148,0	2940	20	191,0	93	302,1	0,80	5600	267,4	130,2	423,0	4150	0,93
342	148,0	2940	20	212,0	93	302,1	0,80	5600	296,8	130,2	423,0	4150	0,93

T _{max} /T _n =3.4		J=0.63Kgm ²		S1					S6/40%				
Poles: 6													
VOLT	HZ	RPM	slip	L _{arm}	KW	Nm	cosφ	const. power max RPM	L _{arm}	KW	Nm	const. power max RPM	Eff. S1
400	42,4	810	38	72,0	39	458,9	0,84	1750	100,8	55	642,5	1250	0,93
400	68,4	1350	18	107,0	57	402,9	0,83	3000	149,8	80	564,1	2050	0,92
400	83,2	1640	23	129,0	69	404,1	0,83	3650	180,6	97	565,7	2450	0,94
400	110,5	2190	20	156,0	81	353,6	0,81	4850	218,4	114	495,0	3300	0,93
400	155,8	3090	26	191,0	98	303,2	0,80	5250	267,4	137	424,4	4350	0,93

T _{max} /T _n =3.4		J=0.63Kgm ²		S1					S6/40%				
Poles: 6													
VOLT	HZ	RPM	slip	L _{arm}	KW	Nm	cosφ	const. power max RPM	L _{arm}	KW	Nm	const. power max RPM	Eff. S1
460	40,3	785	21	62,3	37,5	456,3	0,84	1650	87,3	52,5	638,8	1200	0,90
460	67,4	1330	18	92,2	56	402,2	0,83	2950	129,0	78,4	563,0	2000	0,92
460	79,9	1580	18	108,0	66	399,0	0,83	3500	151,2	92,4	558,6	2400	0,93
460	101,0	2000	20	123,4	74	353,4	0,81	4400	172,8	103,6	494,7	3000	0,93
460	149,5	2970	20	158,8	94	302,3	0,80	5050	222,3	131,6	423,2	4200	0,93

Note: Speed values must be technically compatible with bearings type and applied accessories

DRIVE AX 200L.3

S6 VERSION POWER DERATING: -5% (Tmax/Tn=2.8)

Tmax/Tn=3.5		J=0.75Kgm ²		S1					S6/40%				
Poles: 6													
VOLT	HZ	RPM	slip	L _{arm}	KW	Nm	cosφ	const. power max RPM	L _{arm}	KW	Nm	const. power max RPM	Eff. S1
380	40,2	780	24	86,0	42	514,3	0,81	1750	120,4	58,8	720,0	1250	0,91
354	40,2	780	24	92,3	42	514,3	0,81	1750	129,2	58,8	720,0	1250	0,91
380	49,7	970	24	104,0	51	502,2	0,81	2250	145,6	71,4	703,0	1600	0,92
329	49,7	970	24	120,0	51	502,2	0,81	2250	168,0	71,4	703,0	1600	0,92
380	77,5	1530	20	151,0	74	461,9	0,80	3850	211,4	103,6	646,7	2800	0,93
353	77,5	1530	20	162,5	74	461,9	0,80	3850	227,5	103,6	646,7	2800	0,93
380	102,5	2030	20	183,0	90	423,4	0,81	4900	256,2	126,0	592,8	3500	0,92
349	102,5	2030	20	200,0	90	423,4	0,81	4900	280,0	126,0	592,8	3500	0,92
380	138,0	2740	20	226,0	110	383,4	0,81	5600	316,4	154,0	536,8	4400	0,92
338	138,0	2740	20	254,0	110	383,4	0,81	5600	355,6	154,0	536,8	4400	0,92

Tmax/Tn=3.5		J=0.75Kgm ²		S1					S6/40%				
Poles: 6													
VOLT	HZ	RPM	slip	L _{arm}	KW	Nm	cosφ	const. power max RPM	L _{arm}	KW	Nm	const. power max RPM	Eff. S1
400	42,3	820	26	86,0	44	514,3	0,81	1850	120,4	62	720,0	1300	0,91
400	52,3	1020	26	104,0	54	502,2	0,81	2350	145,6	75	703,0	1700	0,92
400	81,6	1610	22	151,0	78	461,9	0,80	4050	211,4	109	646,7	2950	0,93
400	107,9	2140	18	183,0	95	423,4	0,81	5150	256,2	133	592,8	3700	0,92
400	145,3	2880	25	226,0	116	383,4	0,81	5250	316,4	162	536,8	4650	0,92

Tmax/Tn=3.5		J=0.75Kgm ²		S1					S6/40%				
Poles: 6													
VOLT	HZ	RPM	slip	L _{arm}	KW	Nm	cosφ	const. power max RPM	L _{arm}	KW	Nm	const. power max RPM	Eff. S1
460	41,0	800	20	72,6	43	513,4	0,81	1800	101,7	60,2	718,7	1250	0,92
460	52,2	1020	24	89,3	53	496,3	0,81	2350	125,0	74,2	694,8	1650	0,92
460	80,9	1600	18	130,6	77	459,6	0,80	4000	182,8	107,8	643,5	2900	0,93
460	107,4	2130	18	156,8	94	421,5	0,81	5150	219,5	131,6	590,1	3650	0,93
460	136,8	2720	16	182,7	109	382,7	0,81	5000	255,8	152,6	535,8	4400	0,93

Note: Speed values must be technically compatible with bearings type and applied accessories

DRIVE AX 200L.4

S6 VERSION POWER DERATING: -5% ($T_{max}/T_n=2.7$)

T _{max} /T _n =3.6		J=0.90Kgm ²		S1					S6/40%				
Poles: 6													
VOLT	HZ	RPM	slip	L _{arm}	KW	Nm	cosφ	const. power max RPM	L _{arm}	KW	Nm	const. power max RPM	Eff. S1
380	40,8	790	26	101,0	50	604,5	0,82	1900	141,4	70,0	846,3	1350	0,92
350	40,8	790	26	110,0	50	604,5	0,82	1900	154,0	70,0	846,3	1350	0,92
380	53,4	1050	18	129,0	63	573,1	0,80	2550	180,6	88,2	802,3	1800	0,93
342	53,4	1050	18	143,0	63	573,1	0,80	2550	200,2	88,2	802,3	1800	0,93
380	80,8	1600	16	183,0	90	537,2	0,81	4000	256,2	126,0	752,1	2900	0,93
317	80,8	1600	16	220,0	90	537,2	0,81	4000	308,0	126,0	752,1	2900	0,93
380	103,2	2050	14	208,0	105	489,2	0,82	4950	291,2	147,0	684,9	3500	0,94
380	103,2	2050	14	208,0	105	489,2	0,82	4950	291,2	147,0	684,9	3500	0,94
380	133,0	2650	10	245,0	122	439,7	0,81	5600	343,0	170,8	615,6	4250	0,94
334	133,0	2650	10	278,0	122	439,7	0,81	5600	389,2	170,8	615,6	4250	0,94

T _{max} /T _n =3.6		J=0.90Kgm ²		S1					S6/40%				
Poles: 6													
VOLT	HZ	RPM	slip	L _{arm}	KW	Nm	cosφ	const. power max RPM	L _{arm}	KW	Nm	const. power max RPM	Eff. S1
400	42,9	830	29	101,0	53	604,5	0,82	2000	141,4	74	846,3	1400	0,92
400	56,2	1110	14	129,0	67	573,1	0,80	2700	180,6	93	802,3	1900	0,93
400	85,1	1685	16	183,0	95	537,2	0,81	4200	256,2	133	752,1	3050	0,93
400	108,6	2160	13	208,0	111	489,2	0,82	5200	291,2	155	684,9	3700	0,94
400	140,0	2790	10	245,0	128	439,7	0,81	5250	343,0	180	615,6	4450	0,94

T _{max} /T _n =3.6		J=0.90Kgm ²		S1					S6/40%				
Poles: 6													
VOLT	HZ	RPM	slip	L _{arm}	KW	Nm	cosφ	const. power max RPM	L _{arm}	KW	Nm	const. power max RPM	Eff. S1
460	40,2	785	19	84,5	50	608,4	0,82	1900	118,3	70,0	851,7	1350	0,91
460	53,8	1060	16	107,6	63	567,7	0,80	2550	150,6	88,2	794,7	1850	0,92
460	84,8	1680	16	157,6	94	534,4	0,81	4200	220,6	131,6	748,2	3050	0,93
460	103,7	2060	14	173,2	105	486,8	0,82	4950	242,5	147,0	681,6	3550	0,93
460	128,6	2560	12	197,1	118	440,2	0,81	5000	275,9	165,2	616,3	4100	0,93

Note: Speed values must be technically compatible with bearings type and applied accessories

DRIVE AX 200L.5

NOT AVAILABLE IN S6 VERSION

Tmax/Tn=3.6		J=1.14Kgm ²		S1					S6/40%				
Poles: 6													
VOLT	HZ	RPM	slip	L _{arm}	KW	Nm	cosφ	const. power max RPM	L _{arm}	KW	Nm	const. power max RPM	Eff. S1
380	38,6	750	22	116,0	57	725,9	0,82	1900	162,4	79,8	1016	1350	0,91
345	38,6	750	22	128,0	57	725,9	0,82	1900	179,2	79,8	1016	1350	0,91
380	53,4	1050	18	151,0	73	664,0	0,80	2750	211,4	102,2	930	1950	0,92
332	53,4	1050	18	173,0	73	664,0	0,80	2750	242,2	102,2	930	1950	0,92
380	78,0	1540	20	194,0	97	601,6	0,81	4050	271,6	135,8	842	2850	0,94
342	78,0	1540	20	216,0	97	601,6	0,81	4050	302,4	135,8	842	2850	0,94
380	92,0	1820	20	210,0	107	561,5	0,82	4750	294,0	149,8	786	3300	0,95
337	92,0	1820	20	237,0	107	561,5	0,82	4750	331,8	149,8	786	3300	0,94
380	103,2	2045	19	230,0	117	546,4	0,82	5350	322,0	163,8	765	3700	0,94
327	103,2	2045	19	267,0	117	546,4	0,82	5350	373,8	163,8	765	3700	0,94

Tmax/Tn=3.6		J=1.14Kgm ²		S1					S6/40%				
Poles: 6													
VOLT	HZ	RPM	slip	L _{arm}	KW	Nm	cosφ	const. power max RPM	L _{arm}	KW	Nm	const. power max RPM	Eff. S1
400	40,6	790	23	116,0	60	725,9	0,82	2000	162,4	84	1016	1400	0,91
400	56,2	1110	14	151,0	77	664,0	0,80	2900	211,4	108	930	2050	0,92
400	82,1	1620	22	194,0	102	601,6	0,81	4250	271,6	143	842	3000	0,94
400	96,8	1920	17	210,0	113	561,5	0,82	4800	294,0	158	786	3450	0,95
400	108,6	2150	23	230,0	123	546,4	0,82	5250	322,0	172	765	3900	0,94

Tmax/Tn=3.6		J=1.14Kgm ²		S1					S6/40%				
Poles: 6													
VOLT	HZ	RPM	slip	L _{arm}	KW	Nm	cosφ	const. power max RPM	L _{arm}	KW	Nm	const. power max RPM	Eff. S1
460	39,6	770	22	97,5	58	719,4	0,82	1950	136,5	81,2	1007	1350	0,91
460	57,5	1130	20	133,3	78	659,3	0,80	2950	186,6	109,2	923	2100	0,92
460	78,6	1550	22	160,3	97	597,7	0,81	4050	224,4	135,8	837	2900	0,94
460	91,2	1800	24	171,9	106	562,5	0,82	4500	240,6	148,4	787	3250	0,95
460	101,6	2010	22	186,8	115	546,5	0,82	4900	261,5	161,0	765	3650	0,94

Note: Speed values must be technically compatible with bearings type and applied accessories

Other windings on request

POWERTECH DRIVE AX 250K/KC

ASYNCHRONOUS MOTORS

OVERVIEW

Rev. 1.3

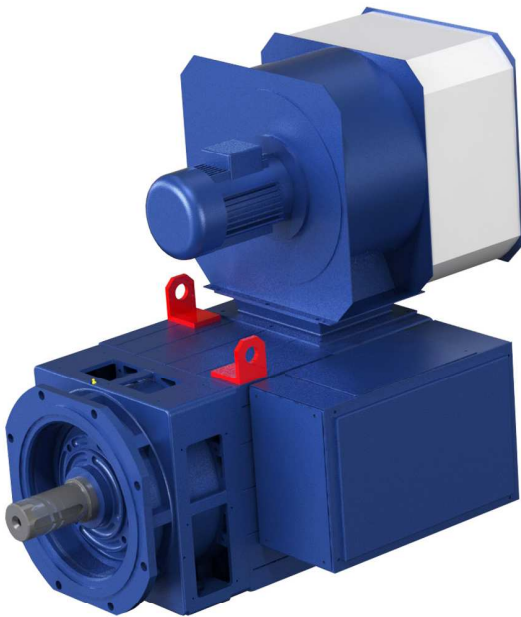

IP PROTECTION	IP54
THERMAL PROTECTION TYPE	KLIXON (PT100, PTC on request)
BALANCING, VIBRATION GRADE (EN 60034-14 / VDE 0530 part 14)	A (B on request)
INSULATION CLASS	F
COOLING METHOD	IC416R (with filter on request)
STANDARD FAN DETAILS	3x230/400Vac 50Hz 11,5/6,6A
Amb. Cond.	0 + 40°C (32 + 104°F) 1000m ASL
TRANSDUCER	ENCODER OR RESOLVER (on request)
MOUNTING FORM	B3, B35, or other on request
BRAKE	up to 2400 Nm (on request)
DE BEARING	BALL (ROLLER on request)
NDE BEARING	BALL (insulated on request)
MAX MECHANICAL SPEED	3500 r.p.m. (3000 r.p.m. roller bearing) 6000 r.p.m. (S6 version)
PAINTING SYSTEM	NITRO, POLYURETHANIC, C5M, on request

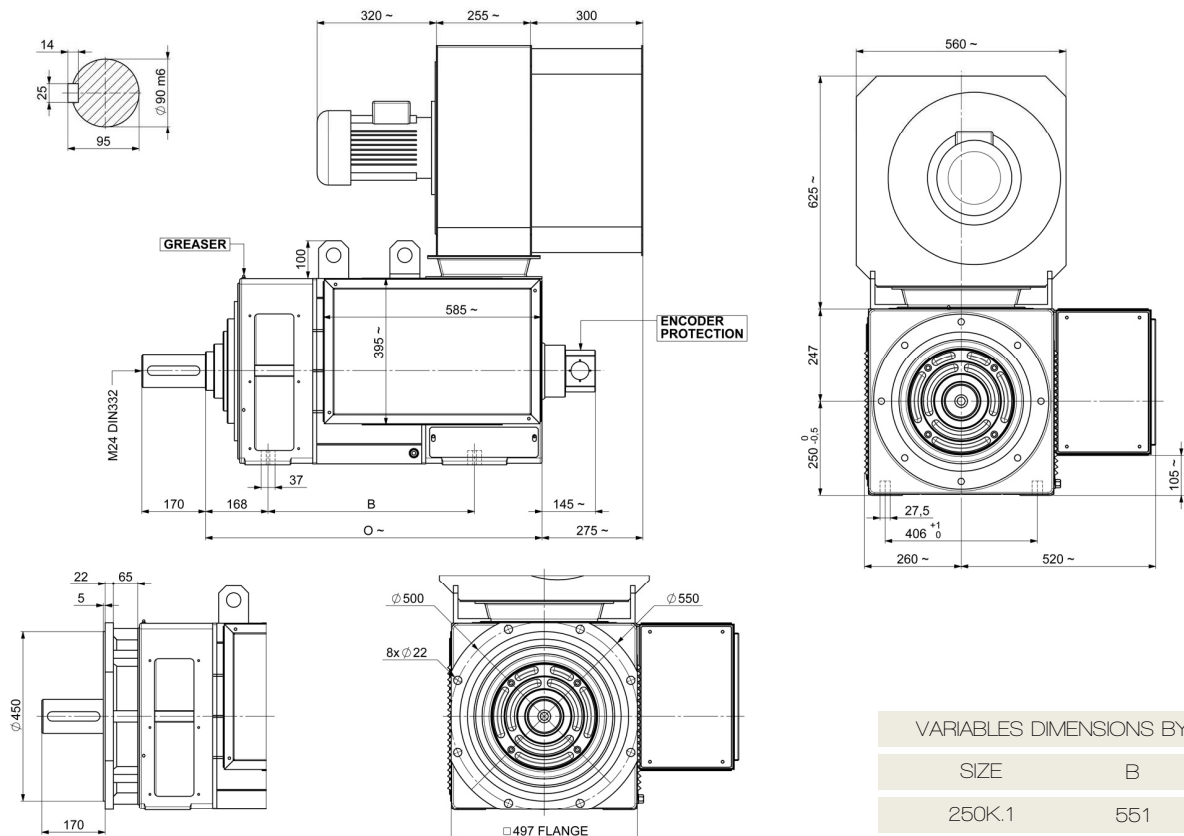

VARIABLES DIMENSIONS BY SIZE		
SIZE	B	O
250K.1	551	900
250K.2	621	970
250K.3	711	1060
250K.4	831	1180
250K.5	971	1320

unit [mm]

DRIVE AX 250K.1

S6 VERSION POWER DERATING: -5%

Poles: 6 Al version												
Tmax/Tn=3.3		J=2.0Kgm ²		S1				S6/40%				
VOLT	HZ	RPM	L _{arm}	KW	Nm	cosφ	const. power max RPM	L _{arm}	KW	Nm	const. power max RPM	Eff. S1
400	51,0	1.010	165	81	770	0,80	2.850	235	115	1.090	1.650	0,90
400	66,5	1.320	205	104	760	0,80	3.700	290	150	1.090	2.150	0,92
400	78,0	1.550	240	121	750	0,80	4.350	340	170	1.050	2.500	0,92
400	99,0	1.970	280	146	710	0,82	4.500	395	205	1.000	3.200	0,93
400	127,0	2.530	335	175	665	0,81	4.500	470	250	945	4.050	0,93
460	58,5	1.160	165	93	770	0,80	3.250	235	135	1.115	1.900	0,90
460	76,5	1.520	205	120	760	0,80	4.300	290	170	1.070	2.450	0,92
460	89,5	1.780	240	139	750	0,80	4.500	340	195	1.050	2.850	0,92
460	114,0	2.270	280	168	710	0,82	4.500	395	240	1.010	3.650	0,93
460	146,0	2.910	335	202	665	0,81	4.500	470	285	940	4.500	0,93

DRIVE AX 250KC.1

NOT AVAILABLE IN S6 VERSION

Poles: 6 Cu version												
Tmax/Tn=3.2		J=2.6Kgm ²		S1				S6/40%				
VOLT	HZ	RPM	L _{arm}	KW	Nm	cosφ	const. power max RPM	L _{arm}	KW	Nm	const. power max RPM	Eff. S1
400	50,9	1.010	175	87	830	0,81	2.850	245	125	1.190	1.650	0,91
400	66,4	1.320	220	112	815	0,81	3.500	310	160	1.160	2.150	0,93
400	77,9	1.550	255	130	805	0,80	3.500	360	185	1.140	2.500	0,93
400	98,9	1.970	295	157	765	0,82	3.500	415	220	1.070	3.200	0,94
400	126,9	2.530	355	190	720	0,82	3.500	500	270	1.020	3.500	0,95
460	58,4	1.160	175	101	830	0,81	3.250	245	145	1.200	1.900	0,91
460	76,4	1.520	220	129	815	0,81	3.500	310	185	1.170	2.450	0,93
460	89,4	1.780	255	150	810	0,80	3.500	360	215	1.155	2.850	0,93
460	113,9	2.270	295	181	760	0,82	3.500	415	255	1.080	3.500	0,94
460	145,9	2.910	355	219	720	0,82	3.500	500	310	1.020	3.500	0,95

Note: Speed values must be technically compatible with bearings type and applied accessories

DRIVE AX 250K.2

S6 VERSION POWER DERATING: -5%

Poles: 6 Al version												
Tmax/Tn=3.4		J=2.5Kgm ²		S1				S6/40%				
VOLT	HZ	RPM	L _{arm}	KW	Nm	cosφ	const. power max RPM	L _{arm}	KW	Nm	const. power max RPM	Eff. S1
400	53,0	1.050	205	103	940	0,80	2.950	290	145	1.320	1.700	0,91
400	68,5	1.360	260	131	920	0,80	3.850	365	185	1.300	2.200	0,92
400	82,0	1.630	305	156	920	0,80	4.500	430	220	1.290	2.650	0,93
400	100,5	2.000	340	177	850	0,81	4.500	480	250	1.200	3.200	0,93
400	130,5	2.600	410	214	790	0,81	4.500	575	300	1.110	4.200	0,94
460	61,0	1.210	205	118	940	0,80	3.400	290	170	1.345	1.950	0,91
460	79,0	1.570	260	151	920	0,80	4.400	365	215	1.310	2.550	0,92
460	94,5	1.880	305	180	915	0,80	4.500	430	255	1.300	3.050	0,93
460	115,5	2.300	340	204	850	0,81	4.500	480	285	1.190	3.700	0,93
460	150,0	2.990	410	246	790	0,81	4.500	575	345	1.110	4.500	0,94

DRIVE AX 250KC.2

NOT AVAILABLE IN S6 VERSION

Poles: 6 Cu version												
Tmax/Tn=3.3		J=3.2Kgm ²		S1				S6/40%				
VOLT	HZ	RPM	L _{arm}	KW	Nm	cosφ	const. power max RPM	L _{arm}	KW	Nm	const. power max RPM	Eff. S1
400	52,9	1.050	215	110	1.005	0,81	2.300	305	155	1.410	1.700	0,92
400	68,4	1.360	270	140	990	0,81	2.950	380	200	1.410	2.200	0,93
400	81,9	1.630	320	166	980	0,81	3.500	450	235	1.380	2.650	0,94
400	100,4	2.000	355	187	900	0,81	3.500	500	265	1.270	3.200	0,94
400	130,4	2.600	430	226	835	0,81	3.500	605	320	1.180	3.500	0,94
460	60,9	1.210	215	127	1.000	0,81	2.650	305	180	1.425	1.950	0,92
460	78,9	1.570	270	162	985	0,81	3.400	380	230	1.400	2.550	0,93
460	94,4	1.880	320	191	975	0,81	3.500	450	270	1.375	3.050	0,94
460	115,4	2.300	355	216	900	0,81	3.500	500	305	1.270	3.500	0,94
460	149,9	2.990	430	260	835	0,81	3.500	605	365	1.170	3.500	0,94

Note: Speed values must be technically compatible with bearings type and applied accessories

DRIVE AX 250K.3

S6 VERSION POWER DERATING: -5% (Tmax/Tn=3.0)

Poles: 6 Al version												
Tmax/Tn=3.6		J=3.1Kgm ²		S1				S6/40%				
VOLT	HZ	RPM	L _{arm}	KW	Nm	cosφ	const. power max RPM	L _{arm}	KW	Nm	const. power max RPM	Eff. S1
400	37,0	730	180	89	1.170	0,80	1.600	255	130	1.710	1.200	0,91
400	50,5	1.000	225	114	1.090	0,80	2.150	315	160	1.530	1.600	0,92
400	77,0	1.530	330	168	1.050	0,80	3.300	465	240	1.500	2.450	0,92
400	92,5	1.840	380	196	1.020	0,80	4.050	535	275	1.430	2.950	0,93
400	113,5	2.260	445	230	975	0,80	4.500	625	325	1.380	3.650	0,94
460	42,5	840	180	103	1.170	0,80	1.850	255	145	1.650	1.350	0,91
460	58,0	1.150	225	131	1.090	0,80	2.500	315	185	1.540	1.850	0,92
460	88,5	1.760	330	193	1.050	0,80	3.800	465	275	1.495	2.850	0,92
460	106,5	2.120	380	225	1.020	0,80	4.500	535	320	1.445	3.400	0,93
460	130,5	2.600	445	265	975	0,80	4.500	625	375	1.380	4.200	0,94

DRIVE AX 250KC.3

NOT AVAILABLE IN S6 VERSION

Poles: 6 Cu version												
Tmax/Tn=3.5		J=3.9Kgm ²		S1				S6/40%				
VOLT	HZ	RPM	L _{arm}	KW	Nm	cosφ	const. power max RPM	L _{arm}	KW	Nm	const. power max RPM	Eff. S1
400	36,9	730	190	95	1.250	0,81	1.600	270	135	1.770	1.200	0,91
400	50,4	1.000	235	121	1.165	0,81	2.150	330	175	1.675	1.600	0,92
400	76,9	1.530	345	180	1.130	0,81	3.300	485	255	1.595	2.450	0,94
400	92,4	1.840	400	209	1.090	0,81	3.500	560	295	1.535	2.950	0,94
400	113,4	2.260	465	245	1.040	0,81	3.500	655	345	1.460	3.500	0,95
460	42,4	840	190	110	1.250	0,81	1.850	270	155	1.765	1.350	0,91
460	57,9	1.150	235	140	1.165	0,81	2.500	330	200	1.665	1.850	0,92
460	88,4	1.760	345	208	1.130	0,81	3.500	485	295	1.605	2.850	0,94
460	106,4	2.120	400	241	1.090	0,81	3.500	560	340	1.535	3.400	0,94
460	130,4	2.600	465	282	1.040	0,81	3.500	655	400	1.470	3.500	0,95

Note: Speed values must be technically compatible with bearings type and applied accessories

DRIVE AX 250K.4

S6 VERSION POWER DERATING: -5% ($T_{max}/T_n=2.4$)

Poles: 6 Al version												
T _{max} /T _n =3.8		J=3.9Kgm ²		S1				S6/40%				
VOLT	HZ	RPM	L _{arm}	KW	Nm	cosφ	const. power max RPM	L _{arm}	KW	Nm	const. power max RPM	Eff. S1
400	39,0	770	230	116	1.440	0,81	2.200	325	165	2.050	1.250	0,91
400	51,5	1.020	290	150	1.410	0,82	2.950	410	215	2.020	1.650	0,92
400	83,0	1.650	450	234	1.360	0,81	4.500	630	330	1.920	2.650	0,93
400	98,0	1.950	480	255	1.250	0,82	4.500	675	360	1.765	3.150	0,94
400	113,0	2.250	535	285	1.210	0,82	4.500	750	400	1.700	3.600	0,94
460	45,0	890	230	133	1.435	0,81	2.550	325	190	2.040	1.450	0,91
460	59,5	1.180	290	173	1.405	0,82	3.400	410	245	1.990	1.900	0,92
460	95,5	1.900	450	270	1.360	0,81	4.500	630	380	1.920	3.050	0,93
460	112,5	2.240	480	293	1.255	0,82	4.500	675	415	1.770	3.600	0,94
460	130,0	2.590	535	328	1.210	0,82	4.500	750	460	1.700	4.150	0,94

DRIVE AX 250KC.4

NOT AVAILABLE IN S6 VERSION

Poles: 6 Cu version												
T _{max} /T _n =3.7		J=4.9Kgm ²		S1				S6/40%				
VOLT	HZ	RPM	L _{arm}	KW	Nm	cosφ	const. power max RPM	L _{arm}	KW	Nm	const. power max RPM	Eff. S1
400	38,9	770	240	124	1.545	0,83	1.700	340	175	2.175	1.250	0,92
400	51,4	1.020	305	161	1.515	0,83	2.200	430	230	2.155	1.650	0,92
400	82,9	1.650	470	250	1.455	0,82	3.500	660	355	2.055	2.650	0,94
400	97,9	1.950	510	272	1.335	0,82	3.500	715	385	1.890	3.150	0,94
400	112,9	2.250	565	302	1.285	0,82	3.500	795	425	1.805	3.500	0,94
460	44,9	890	240	143	1.540	0,83	1.950	340	205	2.205	1.450	0,92
460	59,4	1.180	305	186	1.505	0,83	2.550	430	265	2.150	1.900	0,92
460	95,4	1.900	470	288	1.450	0,82	3.500	660	405	2.040	3.050	0,94
460	112,4	2.240	510	313	1.340	0,82	3.500	715	440	1.880	3.500	0,94
460	129,9	2.590	565	348	1.285	0,82	3.500	795	490	1.810	3.500	0,94

Note: Speed values must be technically compatible with bearings type and applied accessories

DRIVE AX 250K.5

NOT AVAILABLE IN S6 VERSION

Poles: 6 Al version												
Tmax/Tn=3.8		J=4.8Kgm ²		S1				S6/40%				
VOLT	HZ	RPM	L _{arm}	KW	Nm	cosφ	const. power max RPM	L _{arm}	KW	Nm	const. power max RPM	Eff. S1
400	37,4	740	265	136	1.760	0,81	2.150	375	195	2.520	1.200	0,91
400	55,4	1.100	380	196	1.710	0,82	3.150	535	275	2.390	1.800	0,92
400	66,4	1.320	445	232	1.680	0,81	3.800	625	325	2.360	2.150	0,93
400	82,9	1.650	545	283	1.640	0,81	4.500	765	400	2.320	2.650	0,93
400	98,4	1.960	615	321	1.570	0,81	4.500	865	455	2.220	3.150	0,93
460	42,9	850	265	156	1.760	0,81	2.450	375	220	2.475	1.400	0,91
460	63,9	1.270	380	226	1.700	0,82	3.650	535	320	2.410	2.050	0,92
460	76,4	1.520	445	267	1.680	0,81	4.350	625	375	2.360	2.450	0,93
460	95,4	1.900	545	325	1.640	0,81	4.500	765	460	2.315	3.050	0,93
460	113,4	2.260	615	370	1.565	0,81	4.500	865	520	2.200	3.650	0,93

DRIVE AX 250KC.5

NOT AVAILABLE IN S6 VERSION

Poles: 6 Cu version												
Tmax/Tn=3.7		J=5.8Kgm ²		S1				S6/40%				
VOLT	HZ	RPM	L _{arm}	KW	Nm	cosφ	const. power max RPM	L _{arm}	KW	Nm	const. power max RPM	Eff. S1
400	37,3	740	280	146	1.895	0,83	1.600	395	210	2.715	1.200	0,92
400	55,3	1.100	395	207	1.800	0,82	2.400	555	290	2.520	1.800	0,93
400	66,3	1.320	470	247	1.795	0,82	2.850	660	350	2.535	2.150	0,93
400	82,8	1.650	570	303	1.760	0,82	3.500	800	425	2.465	2.650	0,94
400	98,3	1.960	625	335	1.635	0,82	3.500	875	470	2.295	3.150	0,94
460	42,8	850	280	168	1.895	0,83	1.850	395	240	2.700	1.400	0,92
460	63,8	1.270	395	238	1.795	0,82	2.750	555	335	2.520	2.050	0,93
460	76,3	1.520	470	285	1.790	0,82	3.300	660	400	2.515	2.450	0,93
460	95,3	1.900	570	349	1.755	0,82	3.500	800	490	2.465	3.050	0,94
460	113,3	2.260	625	385	1.630	0,82	3.500	875	540	2.285	3.500	0,94

Note: Speed values must be technically compatible with bearings type and applied accessories

Other windings on request

POWERTECH DRIVE AX 250K/KC

ASYNCHRONOUS MOTORS AXIAL FAN VERSION

OVERVIEW

Rev. 1.3

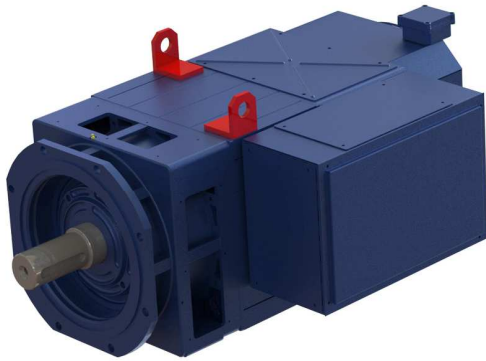

IP PROTECTION	IP54
THERMAL PROTECTION TYPE	KLIXON (PT100, PTC on request)
BALANCING, VIBRATION GRADE (EN 60034-14 / VDE 0530 part 14)	A (B on request)
INSULATION CLASS	F
COOLING METHOD	IC416A
STANDARD FAN DETAILS	3x400Vac 50/60Hz 0,62/0,79A
Amb. Cond.	0 + 40°C (32 + 104°F) 1000m ASL
TRANSDUCER	ENCODER OR RESOLVER (on request)
MOUNTING FORM	B3, B35, or other on request
BRAKE	up to 2400 Nm (on request)
DE BEARING	BALL (ROLLER on request)
NDE BEARING	BALL (insulated on request)
MAX MECHANICAL SPEED	3500 r.p.m. (3000 r.p.m. roller bearing) 6000 r.p.m. (S6 version)
PAINTING SYSTEM	NITRO, POLYURETHANIC, C5M, on request

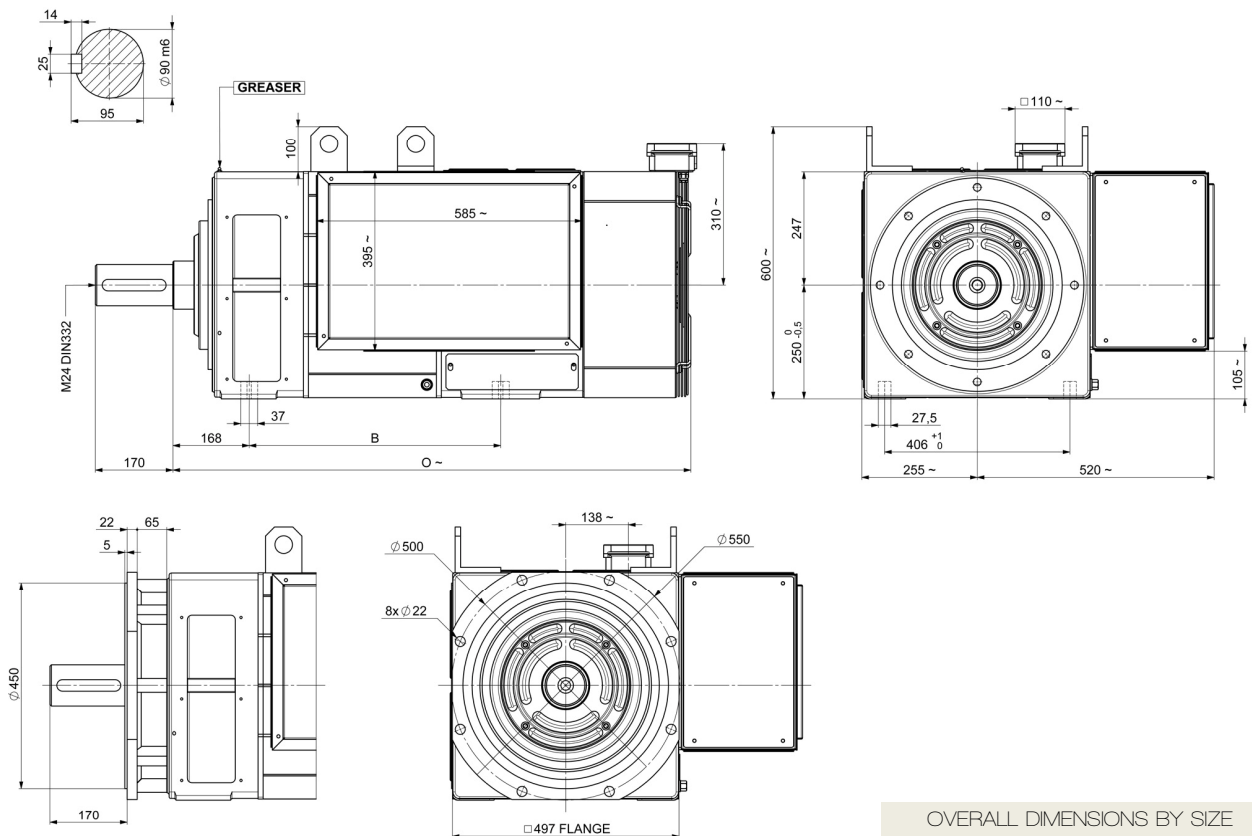

OVERALL DIMENSIONS BY SIZE		
SIZE	B	O
250K.1	551	1150
250K.2	621	1220
250K.3	711	1310
250K.4	831	1430
250K.5	971	1570

unit [mm]

DRIVE AX 250K.1 (AXIAL FAN VERSION)

S6 VERSION POWER DERATING: -5%

Poles: 6 Al version												
Tmax/Tn=3.3		J=2.0Kgm ²		S1				S6/40%				
VOLT	HZ	RPM	L _{arm}	KW	Nm	cosφ	const. power max RPM	L _{arm}	KW	Nm	const. power max RPM	Eff. S1
400	53,5	1.060	155	77	695	0,80	3.000	220	110	995	1.700	0,90
400	70,0	1.390	195	99	685	0,80	3.900	275	140	965	2.250	0,92
400	82,0	1.630	225	115	675	0,80	4.500	315	165	970	2.650	0,92
400	104,0	2.070	265	139	640	0,82	4.500	375	195	900	3.350	0,93
400	133,0	2.650	320	167	605	0,81	4.500	450	235	850	4.250	0,93
460	61,5	1.220	155	88	695	0,80	3.450	220	125	980	2.000	0,90
460	80,5	1.600	195	114	685	0,80	4.500	275	160	955	2.600	0,92
460	94,5	1.880	225	132	675	0,80	4.500	315	190	970	3.050	0,92
460	120,0	2.390	265	160	640	0,82	4.500	375	225	900	3.850	0,93
460	153,5	3.060	320	192	600	0,81	4.500	450	270	845	4.500	0,93

DRIVE AX 250KC.1 (AXIAL FAN VERSION)

NOT AVAILABLE IN S6 VERSION

Poles: 6 Cu version												
Tmax/Tn=3.2		J=2.6Kgm ²		S1				S6/40%				
VOLT	HZ	RPM	L _{arm}	KW	Nm	cosφ	const. power max RPM	L _{arm}	KW	Nm	const. power max RPM	Eff. S1
400	53,4	1.060	165	83	750	0,81	3.000	235	120	1.090	1.700	0,91
400	69,9	1.390	205	107	735	0,81	3.500	290	150	1.040	2.250	0,93
400	81,9	1.630	240	124	730	0,80	3.500	340	175	1.030	2.650	0,93
400	103,9	2.070	280	149	690	0,82	3.500	395	210	970	3.350	0,94
400	132,9	2.650	340	181	655	0,82	3.500	480	255	920	3.500	0,95
460	61,4	1.220	165	96	750	0,81	3.450	235	135	1.060	2.000	0,91
460	80,4	1.600	205	123	735	0,81	3.500	290	175	1.050	2.600	0,93
460	94,4	1.880	240	143	725	0,80	3.500	340	200	1.020	3.050	0,93
460	119,9	2.390	280	172	690	0,82	3.500	395	245	980	3.500	0,94
460	153,4	3.060	340	208	650	0,82	3.500	480	295	930	3.500	0,95

Note: Speed values must be technically compatible with bearings type and applied accessories

DRIVE AX 250K.2 (AXIAL FAN VERSION)

S6 VERSION POWER DERATING: -5%

Poles: 6 Al version													
Tmax/Tn=3.4			J=2.5Kgm ²		S1				S6/40%				
VOLT	HZ	RPM	L _{arm}	KW	Nm	cosφ	const. power max RPM	L _{arm}	KW	Nm	const. power max RPM	Eff. S1	
400	56,0	1.110	195	98	845	0,80	3.150	275	140	1.205	1.800	0,91	
400	72,0	1.430	245	124	835	0,80	4.050	345	175	1.170	2.300	0,92	
400	86,5	1.720	290	149	830	0,80	4.500	410	210	1.170	2.800	0,93	
400	105,5	2.100	320	168	765	0,81	4.500	450	240	1.100	3.400	0,93	
400	137,0	2.730	385	203	715	0,81	4.500	540	285	1.000	4.400	0,94	
460	64,5	1.280	195	113	840	0,80	3.600	275	160	1.195	2.050	0,91	
460	83,0	1.650	245	143	830	0,80	4.500	345	205	1.190	2.650	0,92	
460	99,5	1.980	290	171	825	0,80	4.500	410	240	1.160	3.200	0,93	
460	121,5	2.420	320	193	765	0,81	4.500	450	275	1.090	3.900	0,93	
460	158,0	3.150	385	234	710	0,81	4.500	540	330	1.010	4.500	0,94	

DRIVE AX 250KC.2 (AXIAL FAN VERSION)

NOT AVAILABLE IN S6 VERSION

Poles: 6 Cu version													
Tmax/Tn=3.3			J=3.2Kgm ²		S1				S6/40%				
VOLT	HZ	RPM	L _{arm}	KW	Nm	cosφ	const. power max RPM	L _{arm}	KW	Nm	const. power max RPM	Eff. S1	
400	55,9	1.110	205	105	900	0,81	2.400	290	150	1.295	1.800	0,92	
400	71,9	1.430	255	133	895	0,81	3.100	360	190	1.270	2.300	0,93	
400	86,4	1.720	300	158	880	0,81	3.500	420	225	1.250	2.800	0,94	
400	105,4	2.099	335	178	815	0,81	3.500	470	250	1.140	3.400	0,94	
400	136,9	2.730	405	215	755	0,81	3.500	570	305	1.070	3.500	0,94	
460	64,4	1.280	205	120	900	0,81	2.800	290	170	1.270	2.050	0,92	
460	82,9	1.650	255	153	890	0,81	3.500	360	215	1.250	2.650	0,93	
460	99,4	1.980	300	182	880	0,81	3.500	420	255	1.235	3.200	0,94	
460	121,4	2.420	335	205	810	0,81	3.500	470	290	1.145	3.500	0,94	
460	157,9	3.150	405	247	755	0,81	3.500	570	350	1.065	3.500	0,94	

Note: Speed values must be technically compatible with bearings type and applied accessories

DRIVE AX 250K.3 (AXIAL FAN VERSION)

S6 VERSION POWER DERATING: -5% (Tmax/Tn=3.4)

Poles: 6 Al version												
Tmax/Tn=3.6		J=3.1Kgm ²		S1				S6/40%				
VOLT	HZ	RPM	L _{arm}	KW	Nm	cosφ	const. power max RPM	L _{arm}	KW	Nm	const. power max RPM	Eff. S1
400	38,5	760	165	84	1.060	0,80	1.650	235	120	1.510	1.250	0,91
400	53,0	1.050	210	107	980	0,80	2.300	295	155	1.420	1.700	0,92
400	81,0	1.610	310	158	940	0,80	3.500	435	225	1.335	2.600	0,92
400	97,0	1.930	355	184	915	0,80	4.250	500	260	1.290	3.100	0,93
400	119,5	2.380	415	217	870	0,80	4.500	585	305	1.230	3.850	0,94
460	44,5	880	165	97	1.050	0,80	1.900	235	140	1.530	1.450	0,91
460	61,0	1.210	210	123	975	0,80	2.650	295	175	1.390	1.950	0,92
460	93,0	1.850	310	182	940	0,80	4.000	435	255	1.320	3.000	0,92
460	112,0	2.230	355	212	910	0,80	4.500	500	300	1.285	3.600	0,93
460	137,5	2.740	415	249	870	0,80	4.500	585	350	1.230	4.400	0,94

DRIVE AX 250KC.3 (AXIAL FAN VERSION)

NOT AVAILABLE IN S6 VERSION

Poles: 6 Cu version												
Tmax/Tn=3.5		J=3.9Kgm ²		S1				S6/40%				
VOLT	HZ	RPM	L _{arm}	KW	Nm	cosφ	const. power max RPM	L _{arm}	KW	Nm	const. power max RPM	Eff. S1
400	38,4	760	175	90	1.130	0,81	1.650	245	130	1.635	1.250	0,91
400	52,9	1.050	220	114	1.040	0,81	2.300	310	160	1.455	1.700	0,92
400	80,9	1.610	325	170	1.010	0,81	3.500	455	240	1.425	2.600	0,94
400	96,9	1.930	375	197	975	0,81	3.500	525	280	1.390	3.100	0,94
400	119,4	2.380	435	231	930	0,81	3.500	610	325	1.305	3.500	0,95
460	44,4	880	175	103	1.125	0,81	1.900	245	145	1.575	1.450	0,91
460	60,9	1.210	220	131	1.040	0,81	2.650	310	185	1.465	1.950	0,92
460	92,9	1.850	325	195	1.010	0,81	3.500	455	275	1.420	3.000	0,94
460	111,9	2.230	375	226	970	0,81	3.500	525	320	1.375	3.500	0,94
460	137,4	2.740	435	265	930	0,81	3.500	610	375	1.310	3.500	0,95

Note: Speed values must be technically compatible with bearings type and applied accessories

DRIVE AX 250K.4 (AXIAL FAN VERSION)

S6 VERSION POWER DERATING: -5% (Tmax/Tn=2.8)

Poles: 6 Al version												
Tmax/Tn=3.8		J=3.9Kgm ²		S1				S6/40%				
VOLT	HZ	RPM	L _{arm}	KW	Nm	cosφ	const. power max RPM	L _{arm}	KW	Nm	const. power max RPM	Eff. S1
400	41,5	820	215	109	1.275	0,81	2.350	305	155	1.810	1.350	0,91
400	54,5	1.080	270	141	1.255	0,82	3.100	380	200	1.770	1.750	0,92
400	87,5	1.740	420	220	1.210	0,81	4.500	590	310	1.710	2.800	0,93
400	103,0	2.050	450	240	1.120	0,82	4.500	630	340	1.585	3.300	0,94
400	119,0	2.370	500	268	1.080	0,82	4.500	700	380	1.535	3.800	0,94
460	47,5	940	215	125	1.275	0,81	2.700	305	180	1.830	1.550	0,91
460	62,5	1.240	270	163	1.255	0,82	3.550	380	230	1.780	2.000	0,92
460	100,5	2.000	420	253	1.215	0,81	4.500	590	355	1.700	3.200	0,93
460	118,5	2.360	450	276	1.120	0,82	4.500	630	390	1.580	3.800	0,94
460	137,0	2.730	500	308	1.080	0,82	4.500	700	435	1.525	4.400	0,94

DRIVE AX 250KC.4 (AXIAL FAN VERSION)

NOT AVAILABLE IN S6 VERSION

Poles: 6 Cu version												
Tmax/Tn=3.7		J=4.9Kgm ²		S1				S6/40%				
VOLT	HZ	RPM	L _{arm}	KW	Nm	cosφ	const. power max RPM	L _{arm}	KW	Nm	const. power max RPM	Eff. S1
400	41,4	820	225	117	1.365	0,83	1.800	315	165	1.925	1.350	0,92
400	54,4	1.080	285	152	1.345	0,83	2.350	400	215	1.905	1.750	0,92
400	87,4	1.740	445	235	1.295	0,82	3.500	625	330	1.815	2.800	0,94
400	102,9	2.050	475	256	1.195	0,82	3.500	665	360	1.680	3.300	0,94
400	118,9	2.370	530	284	1.150	0,82	3.500	745	400	1.615	3.500	0,94
460	47,4	940	225	135	1.370	0,83	2.050	315	190	1.930	1.550	0,92
460	62,5	1.242	285	175	1.345	0,83	2.700	400	245	1.885	2.000	0,92
460	100,4	1.999	445	271	1.295	0,82	3.500	625	380	1.820	3.200	0,94
460	118,4	2.360	475	295	1.195	0,82	3.500	665	415	1.680	3.500	0,94
460	136,9	2.730	530	327	1.145	0,82	3.500	745	460	1.610	3.500	0,94

Note: Speed values must be technically compatible with bearings type and applied accessories

DRIVE AX 250K.5 (AXIAL FAN VERSION)

NOT AVAILABLE IN S6 VERSION

Poles: 6 Al version												
Tmax/Tn=3.8		J=4.8Kgm ²		S1				S6/40%				
VOLT	HZ	RPM	L _{arm}	KW	Nm	cosφ	const. power max RPM	L _{arm}	KW	Nm	const. power max RPM	Eff. S1
400	39,4	780	250	128	1.570	0,81	2.250	350	180	2.210	1.250	0,91
400	58,4	1.160	355	185	1.525	0,82	3.350	500	260	2.145	1.900	0,92
400	69,9	1.390	415	218	1.500	0,81	4.000	585	310	2.140	2.250	0,93
400	86,9	1.730	510	266	1.470	0,81	4.500	715	375	2.075	2.800	0,93
400	103,4	2.060	575	302	1.405	0,81	4.500	805	425	1.975	3.300	0,93
460	45,4	900	250	147	1.565	0,81	2.600	350	210	2.230	1.450	0,91
460	67,4	1.340	355	212	1.515	0,82	3.850	500	300	2.140	2.150	0,92
460	80,4	1.600	415	251	1.500	0,81	4.500	585	355	2.120	2.600	0,93
460	100,4	2.000	510	306	1.465	0,81	4.500	715	430	2.055	3.200	0,93
460	119,4	2.380	575	347	1.395	0,81	4.500	805	490	1.970	3.850	0,93

DRIVE AX 250KC.5 (AXIAL FAN VERSION)

NOT AVAILABLE IN S6 VERSION

Poles: 6 Cu version												
Tmax/Tn=3.7		J=5.8Kgm ²		S1				S6/40%				
VOLT	HZ	RPM	L _{arm}	KW	Nm	cosφ	const. power max RPM	L _{arm}	KW	Nm	const. power max RPM	Eff. S1
400	39,3	780	260	138	1.690	0,83	1.700	365	195	2.390	1.250	0,92
400	58,3	1.160	370	195	1.605	0,82	2.500	520	275	2.270	1.900	0,93
400	69,8	1.390	440	233	1.600	0,82	3.000	620	330	2.270	2.250	0,93
400	86,8	1.730	535	285	1.580	0,82	3.500	750	400	2.210	2.800	0,94
400	103,3	2.060	590	315	1.460	0,82	3.500	830	445	2.065	3.300	0,94
460	45,3	900	260	158	1.685	0,83	1.950	365	225	2.395	1.450	0,92
460	67,3	1.340	370	224	1.600	0,82	2.900	520	315	2.250	2.150	0,93
460	80,3	1.600	440	268	1.600	0,82	3.450	620	375	2.240	2.600	0,93
460	100,3	2.000	535	328	1.570	0,82	3.500	750	460	2.200	3.250	0,94
460	119,3	2.380	590	362	1.455	0,82	3.500	830	510	2.050	3.500	0,94

Note: Speed values must be technically compatible with bearings type and applied accessories

Other windings on request

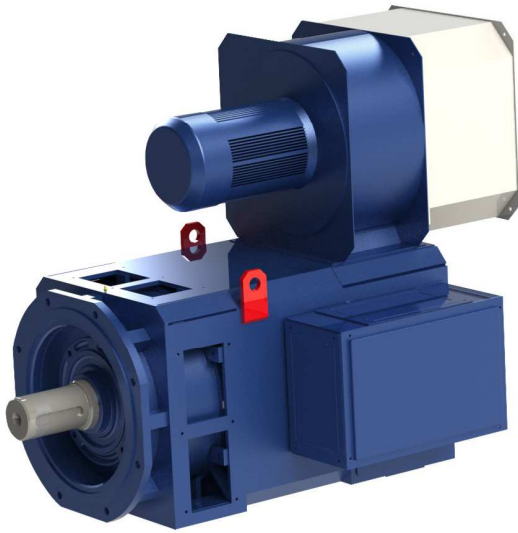

IP PROTECTION	IP54
THERMAL PROTECTION TYPE	KLIXON (PT100, PTC on request)
BALANCING, VIBRATION GRADE (EN 60034-14 / VDE 0530 part 14)	A (B on request)
INSULATION CLASS	F
COOLING METHOD	IC416R (with filter on request)
STANDARD FAN DETAILS	3x230/400Vac 50Hz 19,6/11,3A
Amb. Cond.	0 + 40°C (32 + 104°F) 1000m ASL
TRANSDUCER	ENCODER OR RESOLVER (on request)
MOUNTING FORM	B3, B35, or other on request
BRAKE	up to 2500 Nm (on request)
DE BEARING	BALL (ROLLER on request)
NDE BEARING	BALL (INSULATED)
MAX MECHANICAL SPEED	3200 r.p.m. (2400 r.p.m. roller bearing) 4500 r.p.m. (S6 version)
PAINTING SYSTEM	NITRO, POLYURETHANIC, C5M, on request

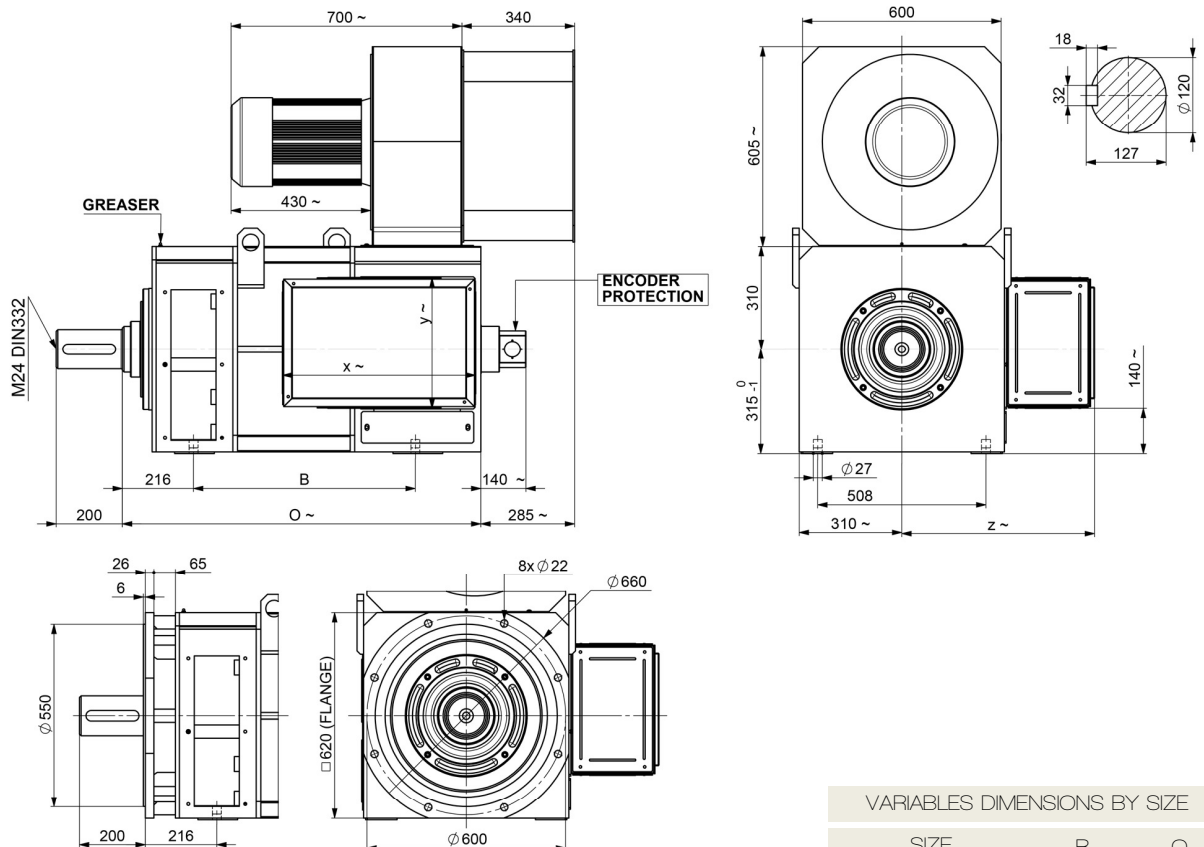

TERMINAL BOX DIMENSIONS			
MOTOR CURRENT	x	y	z
TILL 1500 A	585	400	585
OVER 1500 A	645	534	585

VARIABLES DIMENSIONS BY SIZE		
SIZE	B	O
315L.1	670	1090
315L.2	780	1200
315L.3	900	1320
315L.4	1030	1450
315L.5	1190	1610

unit [mm]

GENERAL DATA

S6 VERSION POWER DERATING: -12%, 315L.5 NOT AVAILABLE IN S6 VERSION

SUPPLY VOLTAGE 690V							Poles: 6		
TYPE	TORQUE Nm	POWER Kw	SPEED rpm	VOLTAGE V	CURRENT A	J Kgm ²	COS ϕ	EFF.	
315L.1	1.800	105	550	690	110,0	8,0	0,85	0,94	RPM 500
315L.2	2.350	140	555	690	145,0	10,4	0,85	0,94	
315L.3	3.050	175	550	690	180,0	12,8	0,86	0,94	
315L.4	3.600	205	540	690	212,0	15,6	0,86	0,95	
315L.5	4.450	255	550	690	265,0	18,8	0,86	0,95	
315L.1	1.700	200	1130	690	210,0	8,0	0,85	0,94	RPM 1000
315L.2	2.200	250	1070	690	260,0	10,4	0,85	0,94	
315L.3	2.850	315	1060	690	325,0	12,8	0,86	0,95	
315L.4	3.450	360	1000	690	370,0	15,6	0,86	0,95	
315L.5	4.200	440	1000	690	450,0	18,8	0,86	0,95	
315L.1	1.600	285	1700	690	295,0	8,0	0,85	0,96	RPM 1500
315L.2	2.100	345	1560	690	355,0	10,4	0,85	0,96	
315L.3	2.700	435	1530	690	440,0	12,8	0,86	0,96	
315L.4	3.250	500	1460	690	500,0	15,6	0,86	0,97	
315L.5	3.900	615	1500	690	615,0	18,8	0,86	0,97	

SUPPLY VOLTAGE 460V							Poles: 6		
TYPE	TORQUE Nm	POWER Kw	SPEED rpm	VOLTAGE V	CURRENT A	J Kgm ²	COS ϕ	EFF.	
315L.1	1.800	110	565	460	170,0	8,0	0,85	0,94	RPM 500
315L.2	2.350	135	555	460	217,0	10,4	0,85	0,94	
315L.3	3.050	175	550	460	271,0	12,8	0,86	0,94	
315L.4	3.600	210	555	460	326,0	15,6	0,86	0,95	
315L.5	4.450	250	535	460	385,0	18,8	0,86	0,95	
315L.1	1.700	190	1080	460	300,0	8,0	0,85	0,94	RPM 1000
315L.2	2.200	240	1040	460	380,0	10,4	0,85	0,94	
315L.3	2.850	300	1000	460	460,0	12,8	0,86	0,95	
315L.4	3.400	375	1050	460	580,0	15,6	0,86	0,95	
315L.5	4.200	455	1040	460	700,0	18,8	0,86	0,95	
315L.1	1.600	255	1520	460	395,0	8,0	0,85	0,96	RPM 1500
315L.2	2.100	330	1500	460	510,0	10,4	0,85	0,96	
315L.3	2.700	420	1500	460	640,0	12,8	0,86	0,96	
315L.4	3.200	505	1500	460	760,0	15,6	0,86	0,97	
315L.5	3.900	560	1370	460	845,0	18,8	0,86	0,97	

Note: Speed values must be technically compatible with bearings type and applied accessories

GENERAL DATA

S6 VERSION POWER DERATING: -12%, 315L.5 NOT AVAILABLE IN S6 VERSION

SUPPLY VOLTAGE 400V							Poles: 6		
TYPE	TORQUE Nm	POWER Kw	SPEED rpm	VOLTAGE V	CURRENT A	J Kgm ²	COS ϕ	EFF.	
315L.1	1.800	100	530	400	183,0	8,0	0,85	0,94	500 RPM
315L.2	2.350	130	535	400	240,0	10,4	0,85	0,94	
315L.3	3.050	175	545	400	310,0	12,8	0,86	0,94	
315L.4	3.600	205	540	400	365,0	15,6	0,86	0,95	
315L.5	4.500	240	510	400	425,0	18,8	0,86	0,95	
315L.1	1.700	180	1000	400	322,0	8,0	0,85	0,94	1000 RPM
315L.2	2.200	230	990	400	413,0	10,4	0,85	0,94	
315L.3	2.800	290	980	400	515,0	12,8	0,86	0,95	
315L.4	3.400	355	1000	400	635,0	15,6	0,86	0,95	
315L.5	4.200	440	1000	400	780,0	18,8	0,86	0,95	
315L.1	1.600	250	1490	400	442,0	8,0	0,85	0,96	1500 RPM
315L.2	2.100	330	1490	400	585,0	10,4	0,85	0,96	
315L.3	2.650	400	1440	400	700,0	12,8	0,86	0,96	
315L.4	3.200	495	1470	400	855,0	15,6	0,86	0,97	
315L.5	3.950	560	1360	400	970,0	18,8	0,86	0,97	

Note: Speed values must be technically compatible with bearings type and applied accessories

Other windings on request

ASYNCHRONOUS MOTORS

RELIABILITY
HIGH EFFICIENCY
HIGH POWER
HIGH TORQUE/WEIGHT RATIO
SUITABLE FOR VECTOR DRIVES
IGBT COMPLIANT
WIDE RANGE OF CUSTOMIZATION AND
OPTIONS

TYPICAL APPLICATIONS

MACHINE TOOLS
COMPRESSORS
TRACTION CONTROL
FOOD BOXES EXTRUDERS
WINDERS AND UNWINDERS
PAPER AND CARDBOARD PRODUCTION
MACHINERY
PROCESSING AND CUTTING METAL PLATES
METAL WIRE PROCESSING MACHINERY
PLASTIC AND RUBBER EXTRUDERS
LIFTING AND HANDLING SYSTEMS
PACKAGING MACHINERY
PRINTING MACHINERY
TEXTILE MACHINERY

IP PROTECTION **IP23**
COOLING METHOD **IC06**

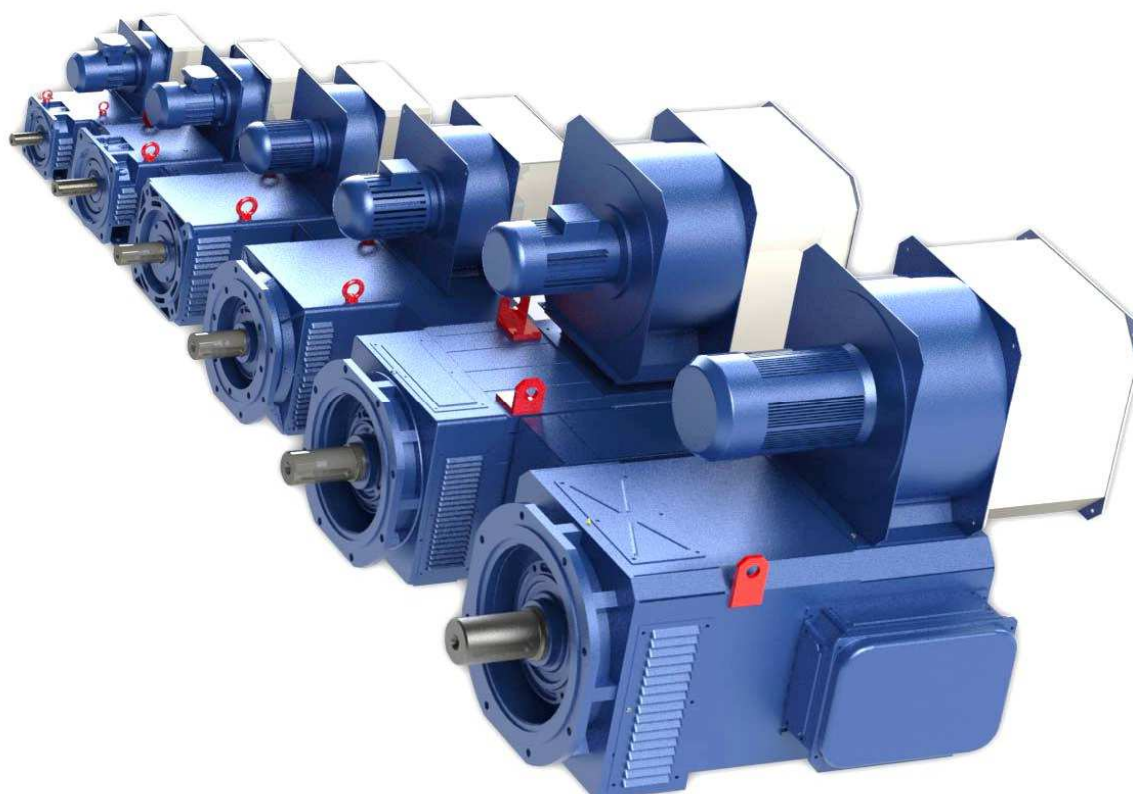

POWERTECH TETRAVEC 100K

ASYNCHRONOUS MOTORS

OVERVIEW

Rev. 1.3

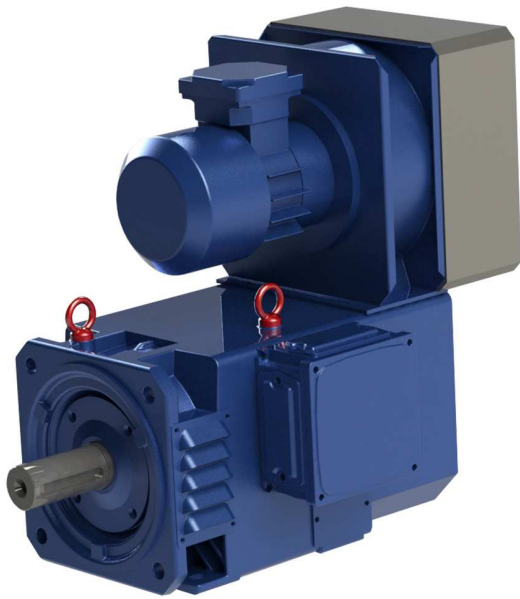

IP PROTECTION	IP23
THERMAL PROTECTION TYPE	KLIXON (PT100, PTC on request)
BALANCING, VIBRATION GRADE (EN 60034-14 / VDE 0530 part 14)	A (B on request)
INSULATION CLASS	F
COOLING METHOD	IC06 (with filter on request)
STANDARD FAN DETAILS	3x230/400Vac 50Hz 0,95/0,55A
Amb. Cond.	0 + 40°C (32 + 104°F) 1000m ASL
TRANSDUCER	ENCODER OR RESOLVER (on request)
MOUNTING FORM	B3, B35, or other on request
BRAKE	up to 95 Nm (on request)
DE BEARING	BALL (ROLLER on request)
NDE BEARING	BALL
MAX MECHANICAL SPEED	9000 r.p.m. (4500 r.p.m. roller bearing) 12000 r.p.m. (S4 version)
PAINTING SYSTEM	NITRO, POLYURETHANIC, C5M, on request

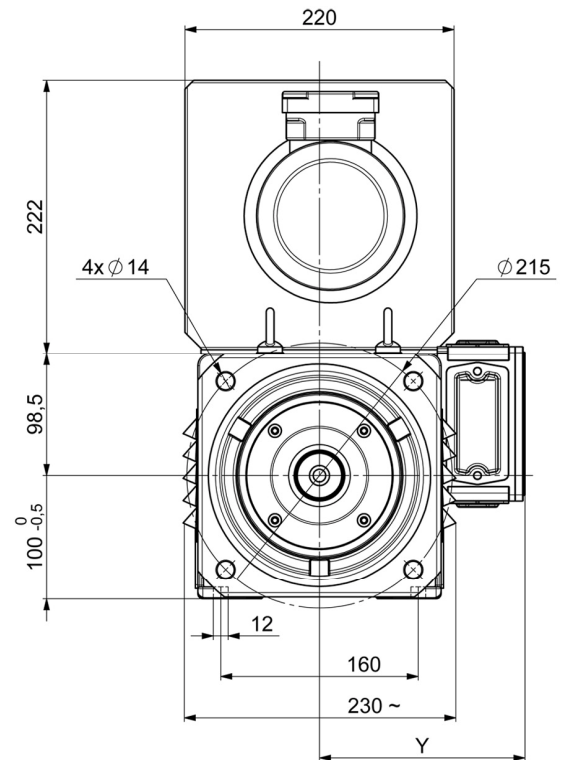
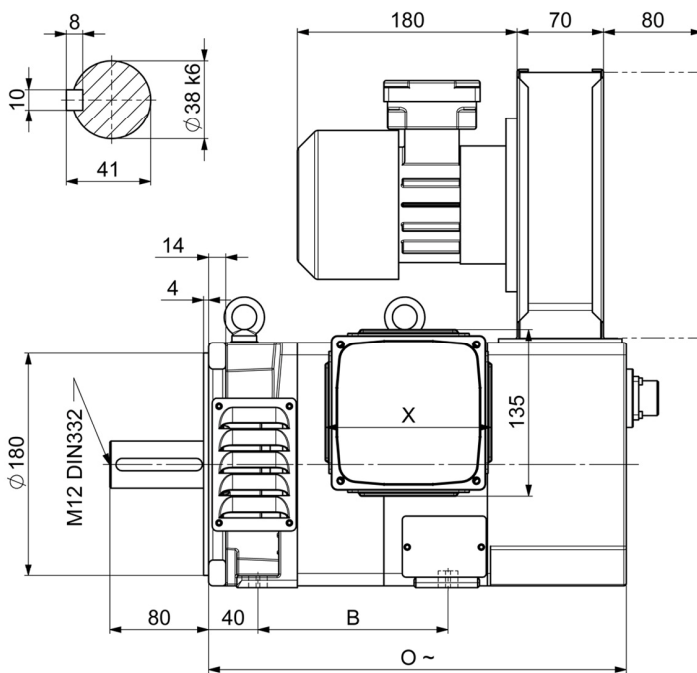

VARIABLES DIMENSIONS BY SIZE

SIZE	B	O	X	Y
100K.1	154	345	135	175
100K.2	179	370	135	175
100K.3	214	405	195	190
100K.4	264	455	195	190
100K.5	304	495	195	190
100K.6	349	540	195	190

unit [mm]

TETRAVEC 100K.1

S4 VERSION POWER DERATING: -5%

Tmax/Tn=2		J=0.0062Kgm ²		S1					S6/40%						
Poles: 4															
VOLT	HZ	RPM	slip	L _{arm}	KW	Nm	cosφ	const. power RPM	L _{arm}	KW	Nm	const. power RPM	Eff. S1		
380	38,5	1050	105	8,9	3,4	30,9	0,79	1600	12,5	4,8	43,3	1200	0,74		
340	38,5	1050	105	9,9	3,4	30,9	0,79	1600	13,9	4,8	43,3	1200	0,74		
380	54,1	1520	103	12,5	4,9	30,8	0,79	2300	17,5	6,9	43,1	1750	0,75		
335	54,1	1520	103	14,2	4,9	30,8	0,79	2300	19,9	6,9	43,1	1750	0,75		
380	74,3	2130	99	16,6	6,7	30,0	0,79	2400	23,2	9,4	42,1	1800	0,78		
335	74,3	2130	99	18,8	6,7	30,0	0,79	3200	26,3	9,4	42,1	2400	0,78		
380	85,9	2490	87	18,1	7,6	29,2	0,78	3750	25,3	10,6	40,8	2850	0,82		
328	85,9	2490	87	21,0	7,6	29,2	0,78	3750	29,4	10,6	40,8	2850	0,82		
380	112,2	3300	66	23,2	9,6	27,8	0,76	4950	32,5	13,4	38,9	3750	0,83		
335	112,2	3300	66	26,3	9,6	27,8	0,76	4950	36,8	13,4	38,9	3750	0,83		
380	129,6	3830	58	26,1	11,0	27,4	0,76	5750	36,5	15,4	38,4	4350	0,84		
330	129,6	3830	58	30,0	11,0	27,4	0,76	5750	42,0	15,4	38,4	4350	0,85		

Tmax/Tn=2		J=0.0062Kgm ²		S1					S6/40%						
Poles: 4															
VOLT	HZ	RPM	slip	L _{arm}	KW	Nm	cosφ	const. power RPM	L _{arm}	KW	Nm	const. power RPM	Eff. S1		
400	40,5	1110	106	8,9	3,6	30,9	0,79	1700	12,5	5,0	43,3	1250	0,74		
400	56,9	1605	103	12,5	5,2	30,8	0,79	2400	17,5	7,2	43,1	1850	0,75		
400	78,2	2250	96	16,6	7,1	30,0	0,79	2550	23,2	9,9	42,1	1900	0,78		
400	90,4	2630	83	18,1	8,0	29,2	0,78	3950	25,3	11,2	40,8	3000	0,82		
400	118,1	3480	63	23,2	10,1	27,8	0,76	5200	32,5	14,2	38,9	3950	0,83		
400	136,4	4030	63	26,1	11,6	27,4	0,76	6050	36,5	16,2	38,4	4600	0,84		

Tmax/Tn=2		J=0.0062Kgm ²		S1					S6/40%						
Poles: 4															
VOLT	HZ	RPM	slip	L _{arm}	KW	Nm	cosφ	const. power RPM	L _{arm}	KW	Nm	const. power RPM	Eff. S1		
460	38,4	1050	102	7,3	3,4	30,9	0,79	1600	10,2	4,8	43,3	1200	0,74		
460	54,3	1530	99	10,3	4,9	30,6	0,79	2300	14,4	6,9	42,8	1750	0,76		
460	74,9	2150	97	13,7	6,7	29,8	0,79	2400	19,2	9,4	41,7	1800	0,78		
460	84,8	2460	84	14,7	7,5	29,1	0,78	3700	20,6	10,5	40,8	2800	0,82		
460	110,0	3230	70	18,8	9,4	27,8	0,76	4850	26,3	13,2	38,9	3650	0,83		
460	130,8	3860	64	21,7	11,1	27,5	0,76	5800	30,4	15,5	38,5	4350	0,85		

Note: Speed values must be technically compatible with bearings type and applied accessories

TETRAVEC 100K.2

S4 VERSION POWER DERATING: -5%

Tmax/Tn=2.1		J=0.0075Kgm ²		S1					S6/40%				
Poles: 4													
VOLT	HZ	RPM	slip	L _{arm}	KW	Nm	cosφ	const. power RPM	L _{arm}	KW	Nm	const. power RPM	Eff. S1
380	36,0	990	90	10,5	4,4	42,4	0,80	1550	14,7	6,2	59,4	1200	0,80
330	36,0	990	90	12,0	4,4	42,4	0,80	1550	16,8	6,2	59,4	1200	0,80
380	53,6	1520	88	15,6	6,6	41,5	0,80	2400	21,8	9,2	58,1	1800	0,80
336	53,6	1520	88	17,5	6,6	41,5	0,80	2400	24,5	9,2	58,1	1800	0,81
380	70,3	2030	79	21,2	8,9	41,9	0,79	3150	29,7	12,5	58,6	2400	0,81
323	70,3	2030	79	24,7	8,9	41,9	0,79	3150	34,6	12,5	58,6	2400	0,82
380	84,2	2460	66	24,0	10,0	38,8	0,78	3850	33,6	14,0	54,4	2900	0,81
335	84,2	2460	66	27,0	10,0	38,8	0,78	3850	37,8	14,0	54,4	2900	0,82
380	104,3	3070	59	29,6	12,4	38,6	0,77	4800	41,4	17,4	54,0	3600	0,83
326	104,3	3070	59	34,5	12,4	38,6	0,77	4800	48,3	17,4	54,0	3600	0,83
380	124,0	3670	50	34,2	14,2	37,0	0,76	5700	47,9	19,9	51,7	4300	0,83
348	124,0	3670	50	37,4	14,2	37,0	0,76	5700	52,4	19,9	51,7	4300	0,83

Tmax/Tn=2.1		J=0.0075Kgm ²		S1					S6/40%				
Poles: 4													
VOLT	HZ	RPM	slip	L _{arm}	KW	Nm	cosφ	const. power RPM	L _{arm}	KW	Nm	const. power RPM	Eff. S1
400	38,0	1080	60	10,7	4,8	42,1	0,80	1700	15,0	6,7	59,0	1250	0,80
400	56,9	1645	63	16,1	7,2	41,6	0,80	2600	22,5	10,0	58,3	1950	0,80
400	73,2	2140	55	21,2	9,4	41,9	0,79	3300	29,7	13,1	58,6	2550	0,81
400	86,9	2560	48	24,0	10,5	39,3	0,78	4000	33,6	14,8	55,0	3000	0,81
400	105,4	3110	51	28,7	12,7	38,9	0,77	4850	40,2	17,7	54,4	3650	0,83
400	122,9	3640	48	32,5	14,2	37,3	0,76	5700	45,5	19,9	52,2	4250	0,83

Tmax/Tn=2.1		J=0.0075Kgm ²		S1					S6/40%				
Poles: 4													
VOLT	HZ	RPM	slip	L _{arm}	KW	Nm	cosφ	const. power RPM	L _{arm}	KW	Nm	const. power RPM	Eff. S1
460	36	990	90	8,6	4,4	42,4	0,80	1550	12,0	6,2	59,4	1200	0,80
460	52,7	1500	81	12,6	6,5	41,4	0,80	2350	17,6	9,1	57,9	1800	0,81
460	70,9	2050	77	17,7	9,0	41,9	0,79	3200	24,8	12,6	58,7	2400	0,81
460	82,6	2410	68	19,6	9,9	39,2	0,78	3750	27,4	13,9	54,9	2850	0,81
460	104,3	3070	59	24,6	12,5	38,9	0,77	4800	34,4	17,5	54,4	3600	0,83
460	120,0	3550	50	27,2	13,7	36,9	0,76	5550	38,1	19,2	51,6	4200	0,83

Note: Speed values must be technically compatible with bearings type and applied accessories

TETRAVEC 100K.3

S4 VERSION POWER DERATING: -5%

Tmax/Tn=2.2		J=0.0102Kgm ²		S1					S6/40%				
Poles: 4													
VOLT	HZ	RPM	slip	L _{arm}	KW	Nm	cosφ	const. power RPM	L _{arm}	KW	Nm	const. power RPM	Rend S1
380	36,4	1030	62	14,5	6,2	57,5	0,81	1650	20,3	8,7	80,5	1250	0,80
327	36,4	1030	62	16,8	6,2	57,5	0,81	1650	23,5	8,7	80,5	1250	0,81
380	53,3	1540	59	21,3	9,2	57,1	0,81	2500	29,8	12,9	79,9	1900	0,81
323	53,3	1540	59	25,1	9,2	57,1	0,81	2500	35,1	12,9	79,9	1900	0,81
380	66,9	1950	57	27,2	11,6	56,8	0,80	3150	38,1	16,2	79,5	2400	0,81
333	66,9	1950	57	31,0	11,6	56,8	0,80	3150	43,4	16,2	79,5	2400	0,81
380	84,0	2470	50	34,0	14,3	55,3	0,79	4000	47,6	20,0	77,4	3000	0,81
321	84,0	2470	50	40,2	14,3	55,3	0,79	4000	56,3	20,0	77,4	3000	0,81
380	100,3	2960	49	39,0	16,3	52,6	0,78	4750	54,6	22,8	73,6	3600	0,82
345	100,3	2960	49	42,9	16,3	52,6	0,78	4750	60,1	22,8	73,6	3600	0,82
380	110,9	3280	47	41,8	17,5	51,0	0,77	5250	58,5	24,5	71,3	3950	0,83
342	110,9	3280	47	46,4	17,5	51,0	0,77	5250	65,0	24,5	71,3	3950	0,83

Tmax/Tn=2.2		J=0.0102Kgm ²		S1					S6/40%				
Poles: 4													
VOLT	HZ	RPM	slip	L _{arm}	KW	Nm	cosφ	const. power RPM	L _{arm}	KW	Nm	const. power RPM	Rend S1
400	38,3	1090	59	14,5	6,6	57,5	0,81	1750	20,3	9,2	80,5	1300	0,80
400	56,1	1620	63	21,3	9,7	57,1	0,81	2650	29,8	13,6	79,9	2000	0,81
400	70,4	2060	53	27,2	12,3	56,8	0,80	3300	38,1	17,2	79,5	2550	0,81
400	88,4	2600	53	34,0	15,1	55,3	0,79	4200	47,6	21,1	77,4	3150	0,81
400	105,6	3120	47	39,0	17,2	52,6	0,78	5000	54,6	24,1	73,6	3800	0,82
400	116,7	3460	42	41,8	18,5	51,0	0,77	5550	58,5	25,8	71,3	4150	0,83

Tmax/Tn=2.2		J=0.0102Kgm ²		S1					S6/40%				
Poles: 4													
VOLT	HZ	RPM	slip	L _{arm}	KW	Nm	cosφ	const. power RPM	L _{arm}	KW	Nm	const. power RPM	Rend S1
460	36,4	1030	62	12,0	6,2	57,5	0,81	1650	16,8	8,7	80,5	1250	0,80
460	53,3	1540	59	17,6	9,2	57,1	0,81	2500	24,6	12,9	79,9	1900	0,81
460	66,9	1950	57	22,5	11,6	56,8	0,80	3150	31,5	16,2	79,5	2400	0,81
460	84	2470	50	28,1	14,3	55,3	0,79	4000	39,3	20,0	77,4	3000	0,81
460	100,3	2960	49	32,2	16,3	52,6	0,78	4750	45,1	22,8	73,6	3600	0,82
460	110,9	3280	47	34,5	17,5	51,0	0,77	5250	48,3	24,5	71,3	3950	0,83

Note: Speed values must be technically compatible with bearings type and applied accessories

TETRAVEC 100K.4

S4 VERSION POWER DERATING: -5%

Tmax/Tn=2.2		J=0.0142Kgm ²		S1					S6/40%				
Poles: 4													
VOLT	HZ	RPM	slip	L _{arm}	KW	Nm	cosφ	const. power RPM	L _{arm}	KW	Nm	const. power RPM	Rend S1
380	37,0	1050	60	20,0	8,4	76,4	0,80	1700	28,0	11,8	107,0	1300	0,80
344	37,0	1050	60	22,0	8,4	76,4	0,80	1700	30,8	11,8	107,0	1300	0,80
380	52,9	1530	57	29,0	12,3	76,8	0,80	2450	40,6	17,2	107,5	1850	0,81
330	52,9	1530	57	33,5	12,3	76,8	0,80	2450	46,9	17,2	107,5	1850	0,80
380	72,2	2110	56	38,5	16,5	74,7	0,80	3400	53,9	23,1	104,6	2550	0,81
345	72,2	2110	56	42,5	16,5	74,7	0,80	3400	59,5	23,1	104,6	2550	0,81
380	80,1	2350	53	40,5	17,5	71,1	0,80	3800	56,7	24,5	99,6	2850	0,82
342	80,1	2350	53	45,0	17,5	71,1	0,80	3800	63,0	24,5	99,6	2850	0,82
380	90,1	2650	53	45,3	19,5	70,3	0,79	4250	63,4	27,3	98,4	3200	0,83
338	90,1	2650	53	51,0	19,5	70,3	0,79	4250	71,4	27,3	98,4	3200	0,83
380	109,0	3220	50	54,0	23,0	68,2	0,78	5200	75,6	32,2	95,5	3900	0,83
322	109,0	3220	50	63,8	23,0	68,2	0,78	5200	89,3	32,2	95,5	3900	0,83

Tmax/Tn=2.2		J=0.0142Kgm ²		S1					S6/40%				
Poles: 4													
VOLT	HZ	RPM	slip	L _{arm}	KW	Nm	cosφ	const. power RPM	L _{arm}	KW	Nm	const. power RPM	Rend S1
400	38,9	1110	58	20,0	8,9	76,4	0,80	1800	28,0	12,4	107,0	1350	0,80
400	55,7	1610	61	29,0	12,9	76,8	0,80	2600	40,6	18,1	107,5	1950	0,81
400	76,0	2220	60	38,5	17,4	74,7	0,80	3600	53,9	24,3	104,6	2700	0,81
400	84,3	2480	49	40,5	18,5	71,1	0,80	4000	56,7	25,9	99,6	3000	0,82
400	94,8	2790	55	45,3	20,5	70,3	0,79	4450	63,4	28,7	98,4	3350	0,83
400	114,7	3390	52	54,0	24,2	68,2	0,78	5450	75,6	33,9	95,5	4100	0,83

Tmax/Tn=2.2		J=0.0142Kgm ²		S1					S6/40%				
Poles: 4													
VOLT	HZ	RPM	slip	L _{arm}	KW	Nm	cosφ	const. power RPM	L _{arm}	KW	Nm	const. power RPM	Rend S1
460	37,7	1070	61	16,7	8,5	75,9	0,80	1750	23,4	11,9	106,2	1350	0,80
460	53,3	1540	59	24,1	12,4	76,9	0,80	2500	33,7	17,4	107,7	1900	0,81
460	74,0	2160	60	32,5	16,9	74,7	0,80	3500	45,5	23,7	104,6	2650	0,82
460	80,8	2370	54	33,6	17,6	70,9	0,80	3800	47,0	24,6	99,3	2850	0,82
460	89,2	2620	56	37,0	19,3	70,4	0,79	4200	51,8	27,0	98,5	3150	0,83
460	110,1	3250	53	45,0	23,2	68,2	0,78	5200	63,0	32,5	95,5	3900	0,83

Note: Speed values must be technically compatible with bearings type and applied accessories

TETRAVEC 100K.5

S4 VERSION POWER DERATING: -5%

Tmax/Tn=2.3		J=0.0168Kgm ²		S1					S6/40%				
Poles: 4													
VOLT	HZ	RPM	slip	L _{arm}	KW	Nm	cosφ	const. power RPM	L _{arm}	KW	Nm	const. power RPM	Rend S1
380	33,0	930	60	20,4	8,6	88,3	0,80	1550	28,6	12,0	123,7	1200	0,80
323	33,0	930	60	24,0	8,6	88,3	0,80	1550	33,6	12,0	123,7	1200	0,80
380	47,3	1360	59	29,2	12,5	87,8	0,80	2250	40,9	17,5	122,9	1700	0,81
316	47,3	1360	59	35,0	12,5	87,8	0,80	2250	49,0	17,5	122,9	1700	0,82
380	55,8	1620	54	33,8	14,5	85,5	0,80	2700	47,3	20,3	119,7	2050	0,82
316	55,8	1620	54	40,6	14,5	85,5	0,80	2700	56,8	20,3	119,7	2050	0,82
380	74,4	2180	52	45,0	19,0	83,2	0,79	3600	63,0	26,6	116,5	2700	0,81
338	74,4	2180	52	50,6	19,0	83,2	0,79	3600	70,8	26,6	116,5	2700	0,81
380	90,0	2650	50	52,7	22,5	81,1	0,79	4250	73,8	31,5	113,5	3200	0,82
321	90,0	2650	50	62,0	22,5	81,1	0,79	4250	86,8	31,5	113,5	3200	0,83
380	107,5	3180	45	61,0	26,0	78,1	0,78	5100	85,4	36,4	109,3	3850	0,83
345	107,5	3180	45	67,2	26,0	78,1	0,78	5100	94,1	36,4	109,3	3850	0,83

Tmax/Tn=2.3		J=0.0168Kgm ²		S1					S6/40%				
Poles: 4													
VOLT	HZ	RPM	slip	L _{arm}	KW	Nm	cosφ	const. power RPM	L _{arm}	KW	Nm	const. power RPM	Rend S1
400	34,7	980	62	20,4	9,1	88,3	0,80	1650	28,6	12,7	123,7	1250	0,80
400	49,8	1435	59	29,2	13,2	87,8	0,80	2350	40,9	18,5	122,9	1800	0,81
400	58,7	1710	52	33,8	15,3	85,5	0,80	2850	47,3	21,4	119,7	2150	0,82
400	78,3	2300	49	45,0	20,1	83,2	0,79	3800	63,0	28,1	116,5	2850	0,81
400	94,7	2794	48	52,7	23,7	81,1	0,79	4450	73,8	33,2	113,5	3350	0,82
400	113,2	3350	45	61,0	27,4	78,1	0,78	5350	85,4	38,3	109,3	4050	0,83

Tmax/Tn=2.3		J=0.0168Kgm ²		S1					S6/40%				
Poles: 4													
VOLT	HZ	RPM	slip	L _{arm}	KW	Nm	cosφ	const. power RPM	L _{arm}	KW	Nm	const. power RPM	Rend S1
460	33,3	940	59	17,0	8,7	88,4	0,80	1600	23,8	12,2	123,8	1200	0,80
460	47,2	1360	56	24,2	12,5	87,8	0,80	2250	33,9	17,5	122,9	1700	0,81
460	54,1	1570	53	27,0	14,0	85,2	0,80	2600	37,8	19,6	119,2	1950	0,81
460	73,8	2160	54	36,8	18,8	83,1	0,79	3600	51,5	26,3	116,4	2700	0,81
460	91,1	2680	53	43,9	22,7	80,9	0,79	4300	61,5	31,8	113,3	3250	0,82
460	110,2	3260	46	51,5	26,6	77,9	0,78	5250	72,1	37,2	109,1	3950	0,83

Note: Speed values must be technically compatible with bearings type and applied accessories

TETRAVEC 100K.6

S4 VERSION POWER DERATING: -5%

Tmax/Tn=2.4		J=0.0198Kgm ²		S1					S6/40%				
Poles: 4													
VOLT	HZ	RPM	slip	L _{arm}	KW	Nm	cosφ	const. power RPM	L _{arm}	KW	Nm	const. power RPM	Rend S1
380	33,6	950	58	24,0	10,2	102,5	0,80	1600	33,6	14,3	143,6	1200	0,81
332	33,6	950	58	27,5	10,2	102,5	0,80	1600	38,5	14,3	143,6	1200	0,81
380	45,8	1320	54	33,0	14,2	102,7	0,80	2200	46,2	19,9	143,8	1650	0,82
342	45,8	1320	54	36,7	14,2	102,7	0,80	2200	51,4	19,9	143,8	1650	0,82
380	55,1	1600	53	40,0	17,2	102,7	0,80	2650	56,0	24,1	143,7	2000	0,82
330	55,1	1600	53	46,0	17,2	102,7	0,80	2650	64,4	24,1	143,7	2000	0,82
380	74,0	2170	50	54,0	23,0	101,2	0,79	3600	75,6	32,2	141,7	2700	0,82
321	74,0	2170	50	64,0	23,0	101,2	0,79	3600	89,6	32,2	141,7	2700	0,82
380	88,0	2590	50	62,0	26,5	97,7	0,79	4150	86,8	37,1	136,8	3150	0,82
345	88,0	2590	50	68,3	26,5	97,7	0,79	4150	95,6	37,1	136,8	3150	0,82
380	98,0	2890	50	65,5	28,0	92,5	0,78	4650	91,7	39,2	129,6	3500	0,83
342	98,0	2890	50	72,7	28,0	92,5	0,78	4650	101,8	39,2	129,6	3500	0,83

Tmax/Tn=2.4		J=0.0198Kgm ²		S1					S6/40%				
Poles: 4													
VOLT	HZ	RPM	slip	L _{arm}	KW	Nm	cosφ	const. power RPM	L _{arm}	KW	Nm	const. power RPM	Rend S1
400	35,4	1000	61	24,0	10,7	102,5	0,80	1700	33,6	15,0	143,6	1250	0,81
400	48,2	1390	56	33,0	15,0	102,7	0,80	2300	46,2	20,9	143,8	1750	0,82
400	58,0	1690	50	40,0	18,2	102,7	0,80	2800	56,0	25,4	143,7	2100	0,82
400	77,9	2290	47	54,0	24,3	101,2	0,79	3800	75,6	34,0	141,7	2850	0,82
400	92,6	2730	49	62,0	27,9	97,7	0,79	4350	86,8	39,1	136,8	3300	0,82
400	103,2	3050	45	65,5	29,5	92,5	0,78	4900	91,7	41,4	129,6	3700	0,83

Tmax/Tn=2.4		J=0.0198Kgm ²		S1					S6/40%				
Poles: 4													
VOLT	HZ	RPM	slip	L _{arm}	KW	Nm	cosφ	const. power RPM	L _{arm}	KW	Nm	const. power RPM	Rend S1
460	34,3	970	59	20,2	10,4	102,4	0,80	1650	28,3	14,6	143,4	1250	0,81
460	47,5	1370	55	28,2	14,7	102,5	0,80	2300	39,5	20,6	143,5	1750	0,82
460	55,4	1610	52	33,2	17,3	102,6	0,80	2700	46,5	24,2	143,7	2050	0,82
460	75,1	2200	53	45,2	23,3	101,2	0,79	3650	63,3	32,6	141,6	2750	0,82
460	90,1	2650	53	52,3	27,1	97,7	0,79	4250	73,2	37,9	136,7	3200	0,82
460	98,7	2910	51	54,5	28,2	92,6	0,78	4700	76,3	39,5	129,6	3550	0,83

Note: Speed values must be technically compatible with bearings type and applied accessories

Other windings on request

POWERTECH TETRAVEC 132K

ASYNCHRONOUS MOTORS

OVERVIEW

Rev. 1.3

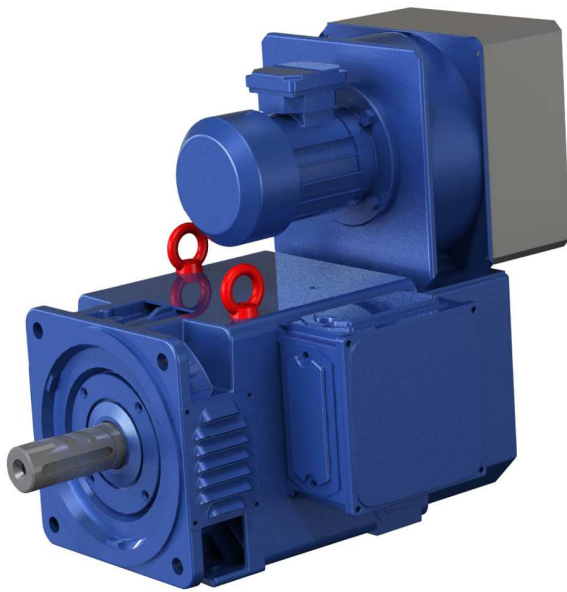

IP PROTECTION	IP23
THERMAL PROTECTION TYPE	KLIXON (PT100, PTC on request)
BALANCING, VIBRATION GRADE (EN 60034-14 / VDE 0530 part 14)	A (B on request)
INSULATION CLASS	F
COOLING METHOD	IC06 (with filter on request)
STANDARD FAN DETAILS	3x230/400Vac 50Hz 1,9/1,1A
Amb. Cond.	0 + 40°C (32 + 104°F) 1000m ASL
TRANSDUCER	ENCODER OR RESOLVER (on request)
MOUNTING FORM	B3, B35, or other on request
BRAKE	up to 300 Nm (on request)
DE BEARING	BALL (ROLLER on request)
NDE BEARING	BALL
MAX MECHANICAL SPEED	6500 r.p.m. (4000 r.p.m. roller bearing) 10000 r.p.m. (S4 version)
PAINTING SYSTEM	NITRO, POLYURETHANIC, C5M, on request

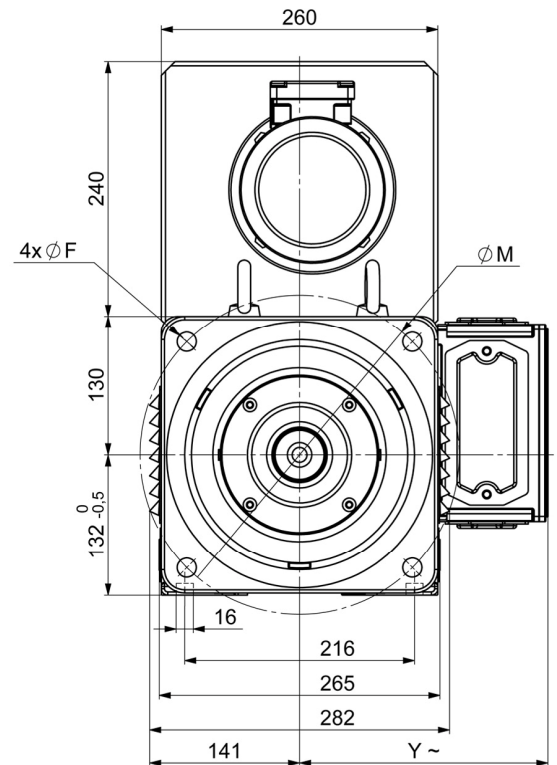
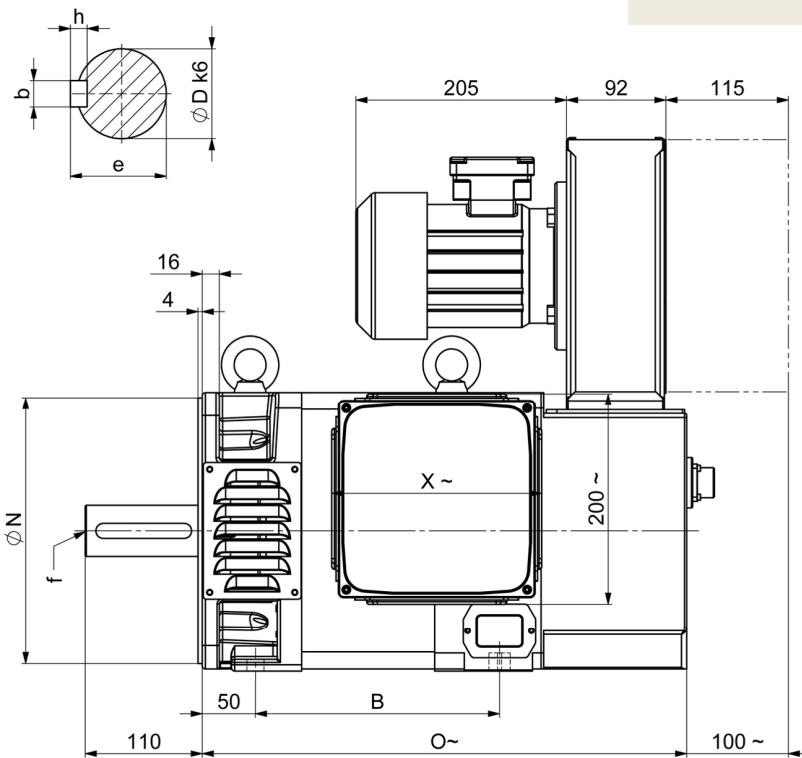

VARIABLES DIMENSIONS BY SIZE

SIZE	B	O	X	Y
132K.1	227	460	200	235
132K.2	272	505	200	235
132K.3	307	540	265	285
132K.4	377	610	265	285
132K.5	447	680	265	285

FLANGE

M	N	F
265	230	14
300	250	18

SHAFT AND KEYWAY

D	bxh	e	f
42 *	12x8	45	M12
48	14x9	51,5	M16

* OPTION

unit [mm]

TETRAVEC 132K.1

S4 VERSION POWER DERATING: -5%

Tmax/Tn=2.1		J=0.042Kgm ²		S1					S6/40%				
Poles: 4													
VOLT	HZ	RPM	slip	L _{arm}	KW	Nm	cosφ	const. power RPM	L _{arm}	KW	Nm	const. power RPM	Eff. S1
380	37,3	1060	59	31,0	15,0	135,2	0,83	1600	43,4	21,0	189,2	1200	0,89
332	37,3	1060	59	35,4	15,0	135,2	0,83	1600	49,6	21,0	189,2	1200	0,89
380	54,4	1580	52	45,0	22,0	133,0	0,83	2400	63,0	30,8	186,2	1800	0,90
346	54,4	1580	52	50,0	22,0	133,0	0,83	2400	70,0	30,8	186,2	1800	0,89
380	74,5	2180	55	58,0	28,0	122,7	0,83	3300	81,2	39,2	171,7	2500	0,88
325	74,5	2180	55	68,0	28,0	122,7	0,83	3300	95,2	39,2	171,7	2500	0,88
380	87,7	2580	51	66,0	32,0	118,5	0,83	3900	92,4	44,8	165,8	2950	0,89
348	87,7	2580	51	72,0	32,0	118,5	0,83	3900	100,8	44,8	165,8	2950	0,89
380	107,3	3170	49	76,5	38,0	114,5	0,82	4800	107,1	53,2	160,3	3600	0,93
342	107,3	3170	49	85,0	38,0	114,5	0,82	4800	119,0	53,2	160,3	3600	0,93
380	126,5	3750	45	85,0	42,0	107,0	0,81	5650	119,0	58,8	149,8	4250	0,93
342	126,5	3750	45	95,0	42,0	107,0	0,81	5650	133,0	58,8	149,8	4250	0,92

Tmax/Tn=2.1		J=0.042Kgm ²		S1					S6/40%				
Poles: 4													
VOLT	HZ	RPM	slip	L _{arm}	KW	Nm	cosφ	const. power RPM	L _{arm}	KW	Nm	const. power RPM	Eff. S1
400	39,3	1120	58	31,0	16	135,2	0,83	1700	43,4	22	189,2	1250	0,89
400	57,3	1670	48	45,0	23	133,0	0,83	2550	63,0	33	186,2	1900	0,90
400	78,4	2300	53	58,0	30	122,7	0,83	3450	81,2	41	171,7	2650	0,88
400	92,3	2720	49	66,0	34	118,5	0,83	4100	92,4	47	165,8	3100	0,89
400	112,9	3340	48	76,5	40	114,5	0,82	5050	107,1	56	160,3	3800	0,93
400	133,2	3950	45	85,0	44	107,0	0,81	5950	119,0	62	149,8	4450	0,93

Tmax/Tn=2.1		J=0.042Kgm ²		S1					S6/40%				
Poles: 4													
VOLT	HZ	RPM	slip	L _{arm}	KW	Nm	cosφ	const. power RPM	L _{arm}	KW	Nm	const. power RPM	Eff. S1
460	38,1	1090	53	26,2	15,4	134,9	0,83	1650	36,7	21,6	188,9	1250	0,89
460	55,8	1620	53	37,8	22,5	132,7	0,83	2450	53,0	31,5	185,8	1850	0,90
460	73,1	2140	53	46,3	27,5	122,7	0,83	3250	64,8	38,5	171,8	2450	0,90
460	91,0	2680	50	55,2	33,0	117,6	0,83	4050	77,3	46,2	164,6	3050	0,91
460	108,3	3200	49	63,3	38,0	113,4	0,82	4800	88,6	53,2	158,8	3600	0,92

Note: Speed values must be technically compatible with bearings type and applied accessories

TETRAVEC 132K.2

S4 VERSION POWER DERATING: -5%

Tmax/Tn=2.2		J=0.056Kgm ²		S1					S6/40%				
Poles: 4													
VOLT	HZ	RPM	slip	L _{arm}	KW	Nm	cosφ	const. power RPM	L _{arm}	KW	Nm	const. power RPM	Eff. S1
380	36,6	1050	48	39,0	19,0	172,8	0,84	1650	54,6	26,6	242,0	1250	0,89
348	36,6	1050	48	42,0	19,0	172,8	0,84	1650	58,8	26,6	242,0	1250	0,90
380	54,9	1600	47	60,0	29,0	173,1	0,84	2500	84,0	40,6	242,4	1900	0,88
332	54,9	1600	47	68,0	29,0	173,1	0,84	2500	95,2	40,6	242,4	1900	0,89
380	68,3	2000	49	72,0	35,0	167,1	0,83	3100	100,8	49,0	234,0	2350	0,89
351	68,3	2000	49	78,0	35,0	167,1	0,83	3100	109,2	49,0	234,0	2350	0,89
380	81,5	2400	45	82,0	40,0	159,2	0,83	3750	114,8	56,0	222,9	2850	0,89
345	81,5	2400	45	90,0	40,0	159,2	0,83	3750	126,0	56,0	222,9	2850	0,90
380	90,4	2670	42	89,0	44,0	157,4	0,83	4150	124,6	61,6	220,4	3150	0,91
342	90,4	2670	42	99,0	44,0	157,4	0,83	4150	138,6	61,6	220,4	3150	0,91
380	115,0	3410	40	105,0	52,0	145,6	0,82	5300	147,0	72,8	203,9	4000	0,92
326	115,0	3410	40	123,0	52,0	145,6	0,82	5300	172,2	72,8	203,9	4000	0,91

Tmax/Tn=2.2		J=0.056Kgm ²		S1					S6/40%				
Poles: 4													
VOLT	HZ	RPM	slip	L _{arm}	KW	Nm	cosφ	const. power RPM	L _{arm}	KW	Nm	const. power RPM	Eff. S1
400	38,5	1110	46	39,0	20	172,8	0,84	1750	54,6	28	242,0	1300	0,89
400	57,8	1690	44	60,0	31	173,1	0,84	2650	84,0	43	242,4	2000	0,88
400	71,9	2110	47	72,0	37	167,1	0,83	3250	100,8	52	234,0	2450	0,89
400	85,8	2530	44	82,0	42	159,2	0,83	3950	114,8	59	222,9	3000	0,89
400	95,2	2810	45	89,0	46	157,4	0,83	4350	124,6	65	220,4	3300	0,91
400	121,1	3590	42	105,0	55	145,6	0,82	5600	147,0	77	203,9	4200	0,92

Tmax/Tn=2.2		J=0.056Kgm ²		S1					S6/40%				
Poles: 4													
VOLT	HZ	RPM	slip	L _{arm}	KW	Nm	cosφ	const. power RPM	L _{arm}	KW	Nm	const. power RPM	Eff. S1
460	38,0	1090	50	33,1	19,5	170,9	0,84	1700	46,3	27,3	239,2	1300	0,89
460	53,3	1550	49	47,9	28,0	172,5	0,84	2450	67,0	39,2	241,6	1850	0,88
460	67,2	1970	46	57,8	34,0	164,8	0,83	3100	80,9	47,6	230,8	2350	0,89
460	85,2	2510	46	71,1	42,0	159,8	0,83	3900	99,6	58,8	223,7	2950	0,89
460	105,8	3130	44	80,1	48,0	146,5	0,82	4900	112,1	67,2	205,1	3700	0,92

Note: Speed values must be technically compatible with bearings type and applied accessories

TETRAVEC 132K.3

S4 VERSION POWER DERATING: -5%

Tmax/Tn=2.2		J=0.067Kgm ²		S1					S6/40%				
Poles: 4													
VOLT	HZ	RPM	slip	L _{arm}	KW	Nm	cosφ	const. power RPM	L _{arm}	KW	Nm	const. power RPM	Eff. S1
380	36,4	1030	62	47,0	23,0	213,3	0,84	1650	65,8	32,2	298,6	1250	0,89
348	36,4	1030	62	51,0	23,0	213,3	0,84	1650	71,4	32,2	298,6	1250	0,89
380	52,0	1500	60	67,0	33,0	210,1	0,84	2400	93,8	46,2	294,2	1800	0,89
325	52,0	1500	60	78,0	33,0	210,1	0,84	2400	109,2	46,2	294,2	1800	0,90
380	67,0	1950	60	84,0	42,0	205,7	0,84	3150	117,6	58,8	288,0	2400	0,91
346	67,0	1950	60	92,0	42,0	205,7	0,84	3150	128,8	58,8	288,0	2400	0,91
380	83,4	2450	52	102,0	50,0	194,9	0,83	3950	142,8	70,0	272,9	3000	0,90
338	83,4	2450	52	115,0	50,0	194,9	0,83	3950	161,0	70,0	272,9	3000	0,90
380	95,5	2820	45	113,0	55,0	186,3	0,83	4550	158,2	77,0	260,8	3450	0,90
330	95,5	2820	45	130,0	55,0	186,3	0,83	4550	182,0	77,0	260,8	3450	0,90
380	111,3	3300	39	126,0	61,0	176,6	0,83	5300	176,4	85,4	247,2	4000	0,89
348	111,3	3300	39	138,0	61,0	176,6	0,83	5300	193,2	85,4	247,2	4000	0,89

Tmax/Tn=2.2		J=0.067Kgm ²		S1					S6/40%				
Poles: 4													
VOLT	HZ	RPM	slip	L _{arm}	KW	Nm	cosφ	const. power RPM	L _{arm}	KW	Nm	const. power RPM	Eff. S1
400	38,3	1090	59	47,0	24	213,3	0,84	1750	65,8	34	298,6	1300	0,89
400	54,7	1580	62	67,0	35	210,1	0,84	2550	93,8	49	294,2	1900	0,89
400	70,5	2060	56	84,0	44	205,7	0,84	3300	117,6	62	288,0	2550	0,91
400	87,8	2580	54	102,0	53	194,9	0,83	4150	142,8	74	272,9	3150	0,90
400	100,5	2970	46	113,0	58	186,3	0,83	4800	158,2	81	260,8	3650	0,90
400	117,2	3480	35	126,0	64	176,6	0,83	5600	176,4	90	247,2	4200	0,89

Tmax/Tn=2.2		J=0.067Kgm ²		S1					S6/40%				
Poles: 4													
VOLT	HZ	RPM	slip	L _{arm}	KW	Nm	cosφ	const. power RPM	L _{arm}	KW	Nm	const. power RPM	Eff. S1
460	36,8	1050	54	39,7	23,5	213,8	0,84	1700	55,5	32,9	299,3	1300	0,89
460	51,8	1500	54	55,3	33,0	210,1	0,84	2400	77,5	46,2	294,2	1800	0,89
460	68,5	2000	55	71,0	43,0	205,3	0,84	3200	99,5	60,2	287,5	2400	0,91
460	82,6	2430	48	83,2	50,0	196,5	0,83	3900	116,5	70,0	275,1	2950	0,91
460	102,8	3040	44	96,0	58,0	182,2	0,83	4900	134,4	81,2	255,1	3700	0,92

Note: Speed values must be technically compatible with bearings type and applied accessories

TETRAVEC 132K.4

S4 VERSION POWER DERATING: -5%

Tmax/Tn=2.2		J=0.104Kgm ²		S1					S6/40%				
Poles: 4													
VOLT	HZ	RPM	slip	L _{arm}	KW	Nm	cosφ	const. power RPM	L _{arm}	KW	Nm	const. power RPM	Eff. S1
380	34,0	960	60	56,0	27,5	273,6	0,84	1550	78,4	38,5	383,0	1200	0,89
333	34,0	960	60	64,0	27,5	273,6	0,84	1550	89,6	38,5	383,0	1200	0,89
380	54,3	1570	59	91,0	45,0	273,8	0,84	2550	127,4	63,0	383,3	1950	0,90
342	54,3	1570	59	101,0	45,0	273,8	0,84	2550	141,4	63,0	383,3	1950	0,90
380	68,5	2000	55	116,0	57,0	272,2	0,84	3200	162,4	79,8	381,1	2400	0,90
329	68,5	2000	55	134,0	57,0	272,2	0,84	3200	187,6	79,8	381,1	2400	0,90
380	79,8	2340	54	128,0	63,0	257,1	0,83	3750	179,2	88,2	360,0	2850	0,90
348	79,8	2340	54	140,0	63,0	257,1	0,83	3750	196,0	88,2	360,0	2850	0,90
380	88,8	2620	44	137,0	67,0	244,2	0,83	4200	191,8	93,8	341,9	3150	0,90
348	88,8	2620	44	149,0	67,0	244,2	0,83	4200	208,6	93,8	341,9	3150	0,91
380	110,6	3280	38	163,0	80,0	233,0	0,83	5250	228,2	112,0	326,1	3950	0,90
338	110,6	3280	38	183,0	80,0	233,0	0,83	5250	256,2	112,0	326,1	3950	0,91

Tmax/Tn=2.2		J=0.104Kgm ²		S1					S6/40%				
Poles: 4													
VOLT	HZ	RPM	slip	L _{arm}	KW	Nm	cosφ	const. power RPM	L _{arm}	KW	Nm	const. power RPM	Eff. S1
400	35,8	1010	64	56,0	29	273,6	0,84	1650	78,4	40	383,0	1250	0,89
400	57,2	1660	55	91,0	48	273,8	0,84	2700	127,4	67	383,3	2050	0,90
400	72,1	2110	53	116,0	60	272,2	0,84	3350	162,4	84	381,1	2550	0,90
400	84,0	2470	50	128,0	67	257,1	0,83	3950	179,2	93	360,0	3000	0,90
400	93,5	2760	44	137,0	71	244,2	0,83	4400	191,8	99	341,9	3300	0,90
400	116,4	3460	33	163,0	84	233,0	0,83	5550	228,2	118	326,1	4150	0,90

Tmax/Tn=2.2		J=0.104Kgm ²		S1					S6/40%				
Poles: 4													
VOLT	HZ	RPM	slip	L _{arm}	KW	Nm	cosφ	const. power RPM	L _{arm}	KW	Nm	const. power RPM	Eff. S1
460	32,9	930	57	44,5	26,5	272,2	0,84	1500	62,4	37,1	381,0	1150	0,89
460	54,8	1590	54	75,2	45,0	270,3	0,84	2550	105,2	63,0	378,4	1950	0,90
460	73,8	2160	54	102,6	61,0	269,7	0,84	3500	143,6	85,4	377,6	2650	0,90
460	91,0	2690	40	113,8	68,0	241,4	0,83	4350	159,3	95,2	338,0	3300	0,91
460	109,5	3250	35	132,4	80,0	235,1	0,83	5200	185,4	112,0	329,1	3900	0,92

Note: Speed values must be technically compatible with bearings type and applied accessories

TETRAVEC 132K.5

S4 VERSION POWER DERATING: -5%

Tmax/Tn=2.3		J=0.130Kgm ²		S1					S6/40%				
Poles: 4													
VOLT	HZ	RPM	slip	L _{arm}	KW	Nm	cosφ	const. power RPM	L _{arm}	KW	Nm	const. power RPM	Eff. S1
380	33,3	940	59	70,0	34,0	345,5	0,84	1600	98,0	47,6	483,7	1200	0,88
321	33,3	940	59	82,0	34,0	345,5	0,84	1600	114,8	47,6	483,7	1200	0,89
380	54,1	1570	53	110,0	55,0	334,6	0,84	2600	154,0	77,0	468,4	1950	0,91
329	54,1	1570	53	127,0	55,0	334,6	0,84	2600	177,8	77,0	468,4	1950	0,91
380	68,7	2010	51	141,0	70,0	332,6	0,84	3350	197,4	98,0	465,7	2550	0,90
345	68,7	2010	51	155,0	70,0	332,6	0,84	3350	217,0	98,0	465,7	2550	0,91
380	76,4	2240	52	153,0	76,0	324,1	0,84	3700	214,2	106,4	453,7	2800	0,90
342	76,4	2240	52	170,0	76,0	324,1	0,84	3700	238,0	106,4	453,7	2800	0,90
380	86,5	2550	45	166,0	82,0	307,1	0,83	4100	232,4	114,8	430,0	3100	0,91
338	86,5	2550	45	187,0	82,0	307,1	0,83	4100	261,8	114,8	430,0	3100	0,90
380	99,0	2930	40	184,0	90,0	293,4	0,83	4700	257,6	126,0	410,7	3550	0,90
332	99,0	2930	40	210,0	90,0	293,4	0,83	4700	294,0	126,0	410,7	3550	0,90

Tmax/Tn=2.3		J=0.130Kgm ²		S1					S6/40%				
Poles: 4													
VOLT	HZ	RPM	slip	L _{arm}	KW	Nm	cosφ	const. power RPM	L _{arm}	KW	Nm	const. power RPM	Eff. S1
400	35,1	990	62	70,0	36	345,5	0,84	1700	98,0	50	483,7	1250	0,88
400	56,9	1655	53	110,0	58	334,6	0,84	2750	154,0	81	468,4	2050	0,91
400	72,3	2120	49	141,0	74	332,6	0,84	3550	197,4	103	465,7	2700	0,90
400	80,4	2360	53	153,0	80	324,1	0,84	3900	214,2	112	453,7	2950	0,90
400	91,1	2690	42	166,0	86	307,1	0,83	4300	232,4	121	430,0	3250	0,91
400	104,2	3090	36	184,0	95	293,4	0,83	4950	257,6	133	410,7	3750	0,90

Tmax/Tn=2.3		J=0.130Kgm ²		S1					S6/40%				
Poles: 4													
VOLT	HZ	RPM	slip	L _{arm}	KW	Nm	cosφ	const. power RPM	L _{arm}	KW	Nm	const. power RPM	Eff. S1
460	34,9	990	57	61,2	36,0	347,3	0,84	1650	85,7	50,4	486,2	1250	0,88
460	52,5	1520	55	87,6	53,0	333,0	0,84	2550	122,6	74,2	466,2	1950	0,91
460	70,5	2060	55	118,2	71,5	331,5	0,84	3400	165,5	100,1	464,1	2550	0,91
460	85,7	2520	51	137,3	83,0	314,6	0,83	4050	192,3	116,2	440,4	3050	0,92
460	106,7	3160	41	158,9	96,0	290,2	0,83	5100	222,5	134,4	406,2	3850	0,92

Note: Speed values must be technically compatible with bearings type and applied accessories

Other windings on request

POWERTECH TETRAVEC 160L

ASYNCHRONOUS MOTORS

OVERVIEW

Rev. 1.3

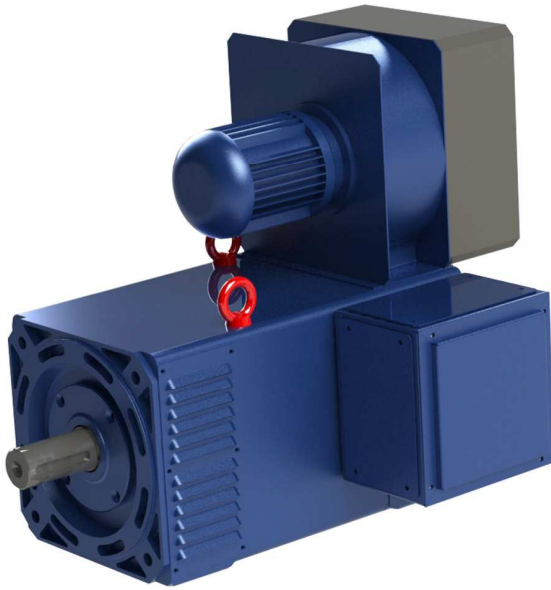

IP PROTECTION	IP23
THERMAL PROTECTION TYPE	KLIXON (PT100, PTC on request)
BALANCING, VIBRATION GRADE (EN 60034-14 / VDE 0530 part 14)	A (B on request)
INSULATION CLASS	F
COOLING METHOD	IC06 (with filter on request)
STANDARD FAN DETAILS	3x230/400Vac 50Hz 4,5/2,6A
Amb. Cond.	0 + 40°C (32 + 104°F) 1000m ASL
TRANSDUCER	ENCODER OR RESOLVER (on request)
MOUNTING FORM	B3, B35, or other on request
BRAKE	up to 400 Nm (on request)
DE BEARING	BALL (ROLLER on request)
NDE BEARING	BALL (insulated on request)
MAX MECHANICAL SPEED	5000 r.p.m. (3500 r.p.m. roller bearing) 8000 r.p.m. (S4 version)
PAINTING SYSTEM	NITRO, POLYURETHANIC, C5M, on request

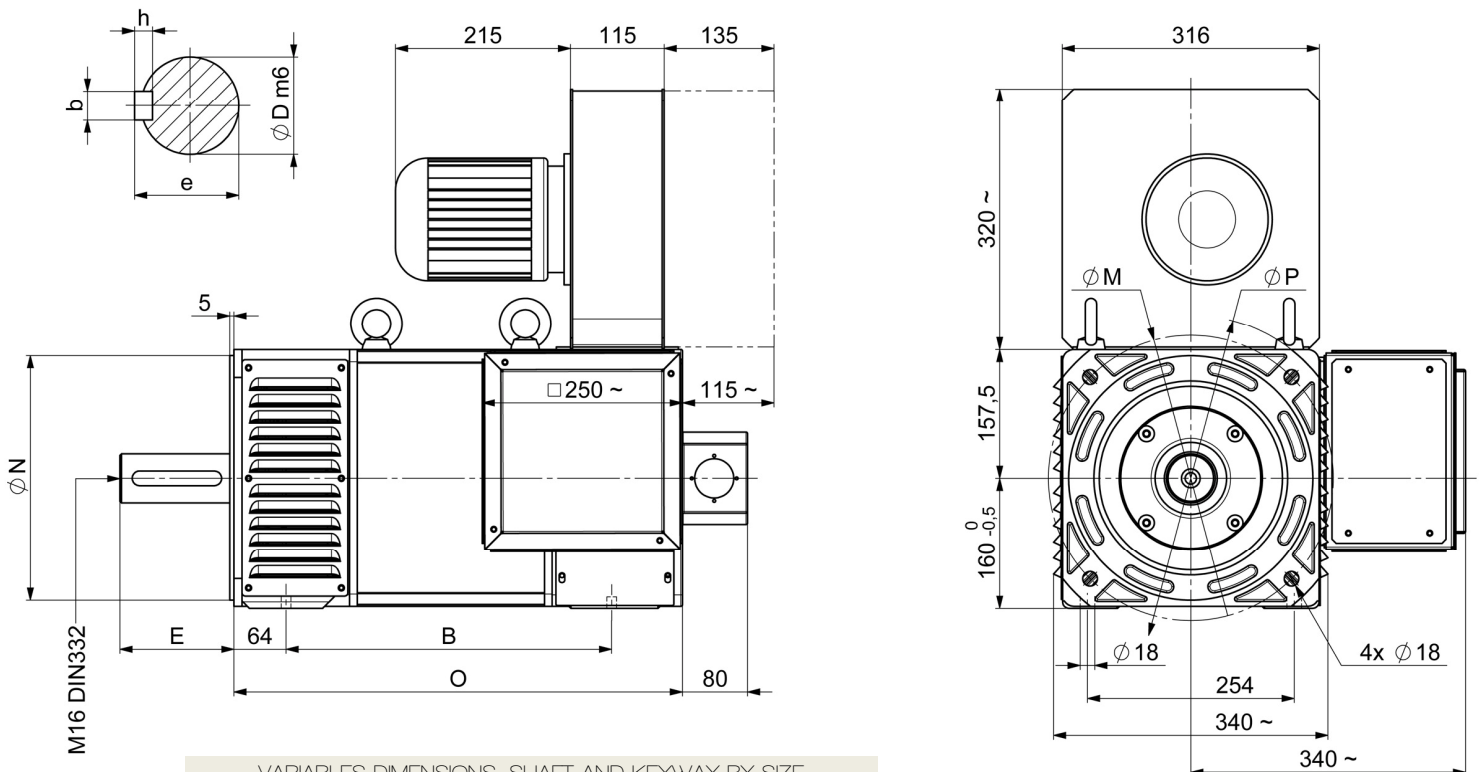

VARIABLES DIMENSIONS, SHAFT AND KEYWAY BY SIZE

SIZE	B	O	DxE	b x h	e
160L.1	400	551	55x110	16x10	59
160L.2	450	601	55x110	16x10	59
160L.3	510	661	60x140	18x11	64
160L.4	570	721	60x140	18x11	64
160L.5	620	771	60x140	18x11	64

FLANGE

P	M	N
400	300	250
400	350	300

unit [mm]

TETRAVEC 160L.1

S4 VERSION POWER DERATING: -5% (Tmax/Tn=1.8)

Tmax/Tn=2.3		J=0.21Kgm ²		S1					S6/40%				
Poles: 4													
VOLT	HZ	RPM	slip	L _{arm}	KW	Nm	cosφ	const. power max RPM	L _{arm}	KW	Nm	const. power max RPM	Eff. S1
380	34,5	1010	25	73,0	35	331	0,82	1550	102,2	49,0	463,4	1200	0,89
338	34,5	1010	25	82,0	35	331	0,82	1550	114,8	49,0	463,4	1200	0,89
380	44,5	1315	20	94,0	45	327	0,82	2000	131,6	63,0	457,6	1500	0,89
345	44,5	1315	20	104,0	45	327	0,82	2000	145,6	63,0	457,6	1500	0,88
380	54,0	1600	20	113,0	55	328	0,82	2400	158,2	77,0	459,6	1850	0,90
342	54,0	1600	20	126,0	55	328	0,82	2400	176,4	77,0	459,6	1850	0,90
380	71,0	2100	30	145,0	70	318	0,82	3150	203,0	98,0	445,7	2400	0,90
338	71,0	2100	30	162,0	70	318	0,82	3150	226,8	98,0	445,7	2400	0,91
380	104,0	3100	20	194,0	93	287	0,80	4650	271,6	130,2	401,1	3550	0,91
345	104,0	3100	20	213,0	93	287	0,80	4650	298,2	130,2	401,1	3550	0,92

Tmax/Tn=2.3		J=0.21Kgm ²		S1					S6/40%				
Poles: 4													
VOLT	HZ	RPM	slip	L _{arm}	KW	Nm	cosφ	const. power max RPM	L _{arm}	KW	Nm	const. power max RPM	Eff. S1
400	36,3	1060	29	73,0	37	331	0,82	1600	102,2	51	463,4	1250	0,89
400	46,8	1380	25	94,0	47	327	0,82	2100	131,6	66	457,6	1600	0,89
400	56,8	1680	25	113,0	58	328	0,82	2550	158,2	81	459,6	1950	0,90
400	74,7	2210	32	145,0	74	318	0,82	3350	203,0	103	445,7	2550	0,90
400	109,5	3260	24	194,0	98	287	0,80	4900	271,6	137	401,1	3750	0,91

Tmax/Tn=2.3		J=0.21Kgm ²		S1					S6/40%				
Poles: 4													
VOLT	HZ	RPM	slip	L _{arm}	KW	Nm	cosφ	const. power max RPM	L _{arm}	KW	Nm	const. power max RPM	Eff. S1
460	34,2	1000	26	60,3	35	334	0,82	1500	84,4	49,0	468,0	1150	0,89
460	54,5	1610	25	93,3	55	326	0,82	2450	130,7	77,0	456,8	1850	0,90
460	74,5	2210	25	124,1	73	315	0,82	3350	173,8	102,2	441,7	2550	0,91
460	87,5	2600	25	141,3	82	301	0,80	3900	197,8	114,8	421,7	3000	0,91
460	106,8	3180	24	163,7	95	285	0,80	4800	229,2	133,0	399,5	3650	0,91

Note: Speed values must be technically compatible with bearings type and applied accessories

TETRAVEC 160L.2

S4 VERSION POWER DERATING: -5% (Tmax/Tn=1.7)

Tmax/Tn=2.3		J=0.25Kgm ²		S1					S6/40%				
Poles: 4													
VOLT	HZ	RPM	slip	L _{arm}	KW	Nm	cosφ	const. power max RPM	L _{arm}	KW	Nm	const. power max RPM	Eff. S1
380	25,5	740	25	64,0	31	400	0,86	1150	89,6	43,4	560,2	900	0,86
342	25,5	740	25	71,0	31	400	0,86	1150	99,4	43,4	560,2	900	0,86
380	37,0	1085	25	91,0	45	396	0,85	1700	127,4	63,0	554,6	1300	0,88
348	37,0	1085	25	100,0	45	396	0,85	1700	140,0	63,0	554,6	1300	0,88
380	56,0	1650	30	134,0	68	394	0,84	2600	187,6	95,2	551,1	1950	0,92
332	56,0	1650	30	151,0	68	394	0,84	2600	211,4	95,2	551,1	1950	0,93
380	76,0	2250	30	168,0	86	365	0,84	3500	235,2	120,4	511,1	2650	0,93
348	76,0	2250	30	183,0	86	365	0,84	3500	256,2	120,4	511,1	2650	0,93
380	94,0	2795	25	194,0	100	342	0,84	4350	271,6	140,0	478,4	3300	0,94
342	94,0	2795	25	215,0	100	342	0,84	4350	301,0	140,0	478,4	3300	0,94

Tmax/Tn=2.3		J=0.25Kgm ²		S1					S6/40%				
Poles: 4													
VOLT	HZ	RPM	slip	L _{arm}	KW	Nm	cosφ	const. power max RPM	L _{arm}	KW	Nm	const. power max RPM	Eff. S1
400	26,8	780	25	64,0	33	400	0,86	1200	89,6	46	560,2	950	0,86
400	38,9	1140	28	91,0	47	396	0,85	1800	127,4	66	554,6	1350	0,88
400	58,9	1740	28	134,0	72	394	0,84	2750	187,6	100	551,1	2050	0,92
400	80,0	2370	30	168,0	91	365	0,84	3700	235,2	127	511,1	2800	0,93
400	98,9	2940	28	194,0	105	342	0,84	4600	271,6	147	478,4	3450	0,94

Tmax/Tn=2.3		J=0.25Kgm ²		S1					S6/40%				
Poles: 4													
VOLT	HZ	RPM	slip	L _{arm}	KW	Nm	cosφ	const. power max RPM	L _{arm}	KW	Nm	const. power max RPM	Eff. S1
460	34,5	1010	25	70,2	42	397	0,85	1600	98,2	58,8	556,0	1200	0,88
460	54,2	1600	25	107,4	66	394	0,84	2500	150,4	92,4	551,7	1900	0,92
460	79,8	2370	24	145,2	90	363	0,84	3700	203,3	126,0	507,8	2800	0,93
460	87,1	2590	23	151,9	94	347	0,84	4050	212,7	131,6	485,3	3050	0,93
460	104,7	3120	21	177,7	110	337	0,83	4850	248,8	154,0	471,4	3700	0,94

Note: Speed values must be technically compatible with bearings type and applied accessories

TETRAVEC 160L.3

S4 VERSION POWER DERATING: -5% (Tmax/Tn=1.6)

Tmax/Tn=2.5		J=0.31Kgm ²		S1					S6/40%				
Poles: 4													
VOLT	HZ	RPM	slip	L _{arm}	KW	Nm	cosφ	const. power max RPM	L _{arm}	KW	Nm	const. power max RPM	Eff. S1
380	26,3	760	29,4	76,0	37	465	0,87	1250	106,4	51,8	651,3	950	0,86
333	26,3	760	29,4	87,0	37	465	0,87	1250	121,8	51,8	651,3	950	0,85
380	40,8	1200	25	114,0	57	454	0,84	1950	159,6	79,8	635,4	1450	0,90
340	40,8	1200	25	127,0	57	454	0,84	1950	177,8	79,8	635,4	1450	0,91
380	52,8	1560	25	144,0	74	453	0,85	2500	201,6	103,6	634,3	1900	0,92
333	52,8	1560	25	165,0	74	453	0,85	2500	231,0	103,6	634,5	1900	0,91
380	74,8	2220	25	194,0	100	430	0,85	3600	271,6	140,0	602,3	2700	0,92
342	74,8	2219	25	215,0	100	430	0,85	3600	301,0	140,0	602,5	2700	0,93
380	96,8	2880	25	235,0	120	398	0,84	4650	329,0	168,0	557,2	3500	0,93
332	96,8	2880	25	268,0	120	398	0,84	4650	375,2	168,0	557,2	3500	0,93

Tmax/Tn=2.5		J=0.31Kgm ²		S1					S6/40%				
Poles: 4													
VOLT	HZ	RPM	slip	L _{arm}	KW	Nm	cosφ	const. power max RPM	L _{arm}	KW	Nm	const. power max RPM	Eff. S1
400	27,7	800	30	76,0	39	465	0,87	1300	106,4	55	651,3	1000	0,86
400	43,0	1260	29	114,0	60	454	0,84	2050	159,6	84	635,4	1550	0,90
400	55,6	1640	28	144,0	78	453	0,85	2650	201,6	109	634,3	2000	0,92
400	78,8	2340	23	194,0	105	430	0,85	3800	271,6	148	602,3	2850	0,92
400	101,9	3030	27	235,0	126	398	0,84	4900	329,0	177	557,2	3700	0,93

Tmax/Tn=2.5		J=0.31Kgm ²		S1					S6/40%				
Poles: 4													
VOLT	HZ	RPM	slip	L _{arm}	KW	Nm	cosφ	const. power max RPM	L _{arm}	KW	Nm	const. power max RPM	Eff. S1
460	36,9	1080	27	85,9	52	460	0,84	1750	120,3	72,8	643,8	1300	0,90
460	51,2	1510	26	115,7	72	455	0,85	2450	162,0	100,8	637,6	1850	0,92
460	75,5	2240	25	160,3	100	426	0,85	3600	224,4	140,0	596,9	2700	0,92
460	93,8	2790	24	187,7	116	397	0,84	4500	262,7	162,4	555,9	3350	0,93
460	104,1	3100	23	204,7	127	391	0,83	5000	286,5	177,8	547,8	3750	0,94

Note: Speed values must be technically compatible with bearings type and applied accessories

TETRAVEC 160L.4

S4 VERSION POWER DERATING: -5% (Tmax/Tn=1.5)

Tmax/Tn=2.5		J=0.36Kgm ²		S1					S6/40%				
Poles: 4													
VOLT	HZ	RPM	slip	L _{arm}	KW	Nm	cosφ	const. power max RPM	L _{arm}	KW	Nm	const. power max RPM	Eff. S1
380	29,6	860	28	99,0	48	533	0,85	1400	138,6	67,2	746,3	1050	0,87
348	29,6	860	28	108,0	48	533	0,85	1400	151,2	67,2	746,3	1050	0,87
380	39,7	1170	20	134,0	65	530	0,83	1900	187,6	91,0	742,6	1450	0,89
338	39,7	1170	20	150,0	65	530	0,83	1900	210,0	91,0	742,6	1450	0,89
380	56,1	1660	23	178,0	90	518	0,84	2700	249,2	126,0	725,0	2000	0,92
310	56,1	1660	23	218,0	90	518	0,84	2700	305,2	126,0	725,0	2000	0,92
380	80,3	2390	20	239,0	120	480	0,82	3850	334,6	168,0	671,5	2900	0,93
332	80,3	2390	20	274,0	120	480	0,82	3850	383,6	168,0	671,5	2900	0,93
380	94,3	2810	20	261,0	132	449	0,83	4500	365,4	184,8	628,2	3400	0,93
325	94,3	2810	20	305,0	132	449	0,83	4500	427,0	184,8	628,2	3400	0,93

Tmax/Tn=2.5		J=0.36Kgm ²		S1					S6/40%				
Poles: 4													
VOLT	HZ	RPM	slip	L _{arm}	KW	Nm	cosφ	const. power max RPM	L _{arm}	KW	Nm	const. power max RPM	Eff. S1
400	31,2	910	25	99,0	51	533	0,85	1450	138,6	71	746,3	1100	0,87
400	41,8	1230	23	134,0	68	530	0,83	2000	187,6	96	742,6	1550	0,89
400	59,1	1750	22	178,0	95	518	0,84	2850	249,2	133	725,0	2100	0,92
400	84,5	2520	16	239,0	127	480	0,82	4050	334,6	177	671,5	3050	0,93
400	99,3	2960	19	261,0	139	449	0,83	4750	365,4	195	628,2	3600	0,93

Tmax/Tn=2.5		J=0.36Kgm ²		S1					S6/40%				
Poles: 4													
VOLT	HZ	RPM	slip	L _{arm}	KW	Nm	cosφ	const. power max RPM	L _{arm}	KW	Nm	const. power max RPM	Eff. S1
460	36,1	1060	23	100,5	59	532	0,83	1700	140,7	82,6	744,3	1300	0,89
460	54,1	1600	23	142,1	87	519	0,84	2600	199,0	121,8	727,1	1950	0,92
460	70,0	2080	20	175,2	106	487	0,82	3350	245,3	148,4	681,4	2500	0,93
460	86,7	2580	20	211,3	129	478	0,83	4150	295,8	180,6	668,7	3100	0,93
460	100,0	2980	20	225,0	138	442	0,82	4800	314,9	193,2	619,2	3600	0,94

Note: Speed values must be technically compatible with bearings type and applied accessories

TETRAVEC 160L.5

NOT AVAILABLE IN S4 VERSION

Tmax/Tn=2.5		J=0.40Kgm ²		S1					S6/40%				
Poles: 4													
VOLT	HZ	RPM	slip	L _{arm}	KW	Nm	cos φ	const. power max RPM	L _{arm}	KW	Nm	const. power max RPM	Eff. S1
380	28,7	830	31	107,0	52	598	0,85	1350	149,8	72,8	837,7	1000	0,87
311	28,7	830	31	131,0	52	598	0,85	1350	183,4	72,8	837,7	1000	0,87
380	35,3	1030	29	131,0	64	593	0,83	1650	183,4	89,6	830,9	1250	0,90
338	35,3	1030	29	148,0	64	593	0,83	1650	207,2	89,6	830,9	1250	0,89
380	45,7	1340	31	169,0	83	592	0,83	2150	236,6	116,2	828,2	1650	0,90
348	45,7	1340	31	183,0	83	592	0,84	2150	256,2	116,2	828,2	1650	0,90
380	55,0	1620	30	198,0	100	590	0,84	2600	277,2	140,0	825,4	1950	0,92
342	55,0	1620	30	221,0	100	590	0,83	2600	309,4	140,0	825,4	1950	0,92
380	70,8	2090	34	240,0	120	548	0,82	3350	336,0	168,0	767,7	2550	0,93
332	70,8	2090	34	275,0	120	548	0,83	3350	385,0	168,0	767,7	2550	0,92
380	81,8	2420	34	269,0	136	537	0,83	3900	376,6	190,4	751,5	2950	0,93
326	81,8	2420	34	314,0	136	537	0,83	3900	439,6	190,4	751,5	2950	0,93

Tmax/Tn=2.5		J=0.40Kgm ²		S1					S6/40%				
Poles: 4													
VOLT	HZ	RPM	slip	L _{arm}	KW	Nm	cos φ	const. power max RPM	L _{arm}	KW	Nm	const. power max RPM	Eff. S1
400	37,2	1080	35	131,0	67	593	0,83	1750	183,4	94	830,9	1300	0,89
400	48,1	1410	33	169,0	87	592	0,83	2300	236,6	122	828,2	1700	0,90
400	57,9	1710	27	198,0	106	590	0,84	2750	277,2	148	825,4	2100	0,92
400	74,5	2200	36	240,0	126	548	0,82	3550	336,0	177	767,7	2650	0,93
400	86,1	2550	35	269,0	143	537	0,83	4100	376,6	201	751,5	3100	0,93

Tmax/Tn=2.5		J=0.40Kgm ²		S1					S6/40%				
Poles: 4													
VOLT	HZ	RPM	slip	L _{arm}	KW	Nm	cos φ	const. power max RPM	L _{arm}	KW	Nm	const. power max RPM	Eff. S1
460	34,9	1020	27	107,2	63,4	594	0,83	1650	150,1	88,8	831,1	1250	0,90
460	42,7	1250	31	129,6	77,5	592	0,84	2000	181,4	108,5	829,0	1500	0,90
460	55,0	1620	30	166,2	100	590	0,82	2600	232,6	140,0	825,4	1950	0,92
460	68,4	2030	22	192,7	117	550	0,83	3250	269,7	163,8	770,7	2450	0,93
460	86,7	2580	20	236,1	144	533	0,82	4150	330,6	201,6	746,5	3100	0,93

Note: Speed values must be technically compatible with bearings type and applied accessories

Other windings on request

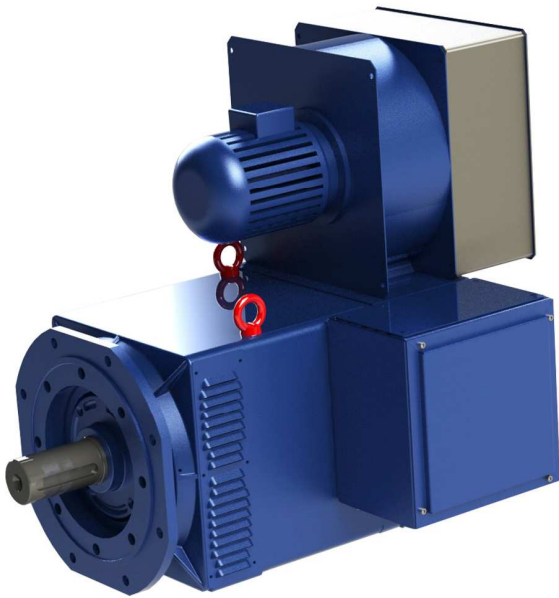

IP PROTECTION	IP23
THERMAL PROTECTION TYPE	KLIXON (PT100, PTC on request)
BALANCING, VIBRATION GRADE (EN 60034-14 / VDE 0530 part 14)	A (B on request)
INSULATION CLASS	F
COOLING METHOD	IC06 (with filter on request)
STANDARD FAN DETAILS	3x230/400Vac 50Hz 5,7/3,3A
Amb. Cond.	0 + 40°C (32 + 104°F) 1000m ASL
TRANSDUCER	ENCODER OR RESOLVER (on request)
MOUNTING FORM	B3, B35, or other on request
BRAKE	up to 600 Nm (on request)
DE BEARING	BALL (ROLLER on request)
NDE BEARING	BALL (insulated on request)
MAX MECHANICAL SPEED	4000 r.p.m. (3200 r.p.m. roller bearing) 6500 r.p.m. (S6 version)
PAINTING SYSTEM	NITRO, POLYURETHANIC, C5M, on request

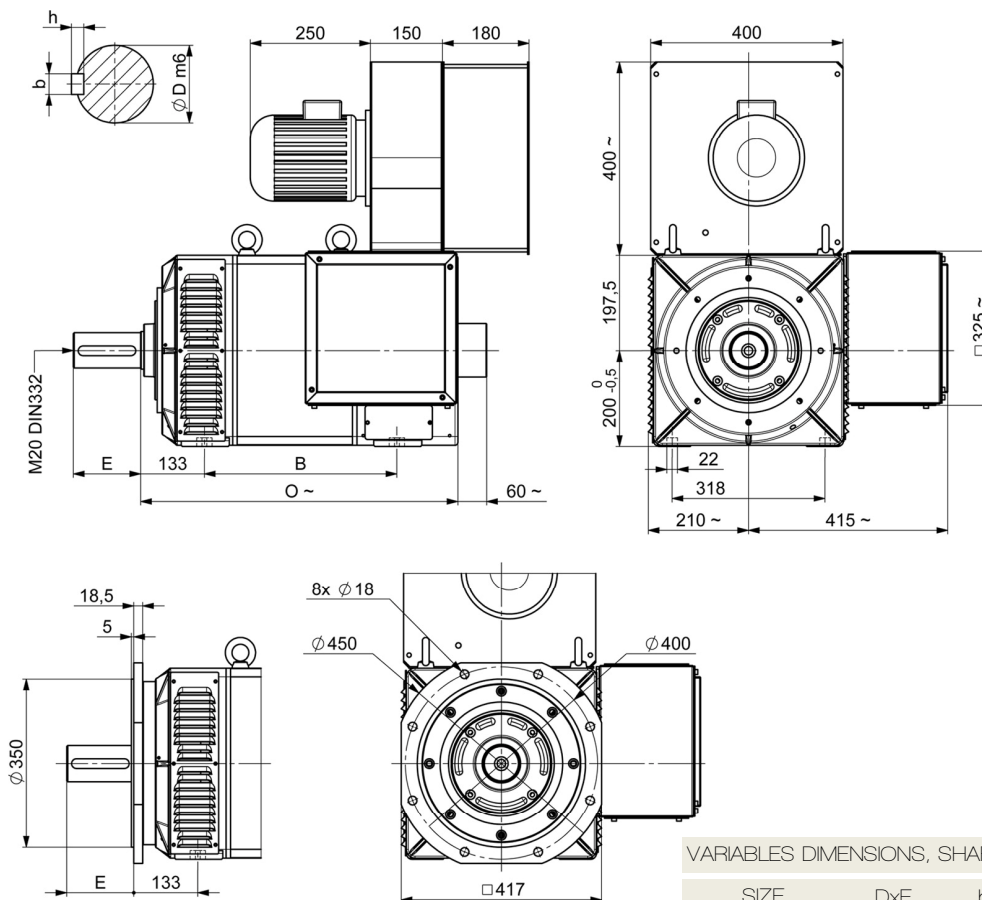

VARIABLES DIMENSIONS, SHAFT AND KEYWAY BY SIZE

SIZE	DxE	bxh	B	O
200L.1	65x140	18x11	400	660
200L.2	65x140	18x11	440	700
200L.3	65x140	18x11	490	750
200L.4	75x140	20x12	560	820
200L.5	75x140	20x12	660	920

unit [mm]

TETRAVEC 200L.1

S6 VERSION POWER DERATING: -5% (Tmax/Tn=1.7)

Tmax/Tn=2.2		J=0.55Kgm ²		S1					S6/40%						
Poles: 6															
VOLT	HZ	RPM	slip	L _{arm}	KW	Nm	cosφ	const. power max RPM	L _{arm}	KW	Nm	const. power max RPM	Rend S1		
380	44,5	870	20	131,0	66	725	0,86	1350	183,4	92,4	1014	1050	0,89		
316	44,5	870	20	158,0	66	725	0,86	1350	221,2	92,4	1014	1050	0,89		
380	59,5	1170	20	172,0	88	718	0,85	1850	240,8	123,2	1006	1400	0,92		
343	59,5	1170	20	190,0	88	718	0,85	1850	266,0	123,2	1006	1400	0,92		
380	83,8	1655	21	227,0	118	681	0,85	2600	317,8	165,2	953	1950	0,93		
342	83,8	1655	21	252,0	118	681	0,85	2600	352,8	165,2	953	1950	0,93		
380	95,5	1890	20	248,0	130	657	0,84	2950	347,2	182,0	920	2200	0,95		
380	116,5	2310	20	290,0	150	620	0,84	3600	406,0	210,0	868	2700	0,94		
380	141,0	2800	20	323,0	170	580	0,85	4350	452,2	238,0	812	3250	0,95		
345	141,0	2800	20	357,0	170	580	0,85	4350	499,8	238,0	812	3250	0,94		

Tmax/Tn=2.2		J=0.55Kgm ²		S1					S6/40%						
Poles: 6															
VOLT	HZ	RPM	slip	L _{arm}	KW	Nm	cosφ	const. power max RPM	L _{arm}	KW	Nm	const. power max RPM	Rend S1		
400	46,8	920	17	131,0	70	725	0,86	1400	183,4	97	1014	1100	0,89		
400	62,6	1230	23	172,0	92	718	0,85	1950	240,8	129	1006	1450	0,92		
400	88,2	1740	24	227,0	124	681	0,85	2750	317,8	174	953	2050	0,93		
400	122,6	2430	23	290,0	158	620	0,84	3800	406,0	221	868	2850	0,94		
400	148,4	2950	18	323,0	179	580	0,85	4600	452,2	251	812	3400	0,95		

Tmax/Tn=2.2		J=0.55Kgm ²		S1					S6/40%						
Poles: 6															
VOLT	HZ	RPM	slip	L _{arm}	KW	Nm	cosφ	const. power max RPM	L _{arm}	KW	Nm	const. power max RPM	Rend S1		
460	46,2	900	24	111,5	68	722	0,86	1400	156,1	95,2	1010	1050	0,89		
460	60,0	1180	20	142,1	88	712	0,85	1850	198,9	123,2	997	1400	0,92		
460	84,5	1670	20	189,1	119	681	0,85	2600	264,8	166,6	953	1950	0,93		
460	118,0	2340	20	242,8	152	620	0,84	3650	339,9	212,8	869	2750	0,94		
460	144,0	2860	20	270,0	172	574	0,85	4450	378,0	240,8	804	3350	0,95		

Note: Speed values must be technically compatible with bearings type and applied accessories

TETRAVEC 200L.2

S6 VERSION POWER DERATING: -5% (Tmax/Tn=1.6)

Tmax/Tn=2.2		J=0.63Kgm ²		S1					S6/40%				
Poles: 6													
VOLT	HZ	RPM	slip	L _{arm}	KW	Nm	cosφ	const. power max RPM	L _{arm}	KW	Nm	const. power max RPM	Rend S1
380	45,5	880	30	155,0	77	836	0,84	1450	217,0	107,8	1170	1100	0,90
330	45,5	880	30	180,0	77	836	0,84	1450	252,0	107,8	1170	1100	0,89
380	62,5	1230	20	206,0	105	815	0,85	2000	288,4	147,0	1141	1500	0,92
345	62,5	1230	20	227,0	105	815	0,85	2000	317,8	147,0	1141	1500	0,92
380	82,0	1620	20	254,0	132	778	0,85	2600	355,6	184,8	1090	1950	0,94
350	82,0	1620	20	275,0	132	778	0,85	2600	385,0	184,8	1090	1950	0,94
380	118,0	2340	20	335,0	175	714	0,84	3750	469,0	245,0	1000	2850	0,95
345	118,0	2340	20	368,0	175	714	0,84	3750	515,2	245,0	1000	2850	0,95
380	146,0	2900	20	385,0	200	659	0,84	4650	539,0	280,0	922	3500	0,95
338	146,0	2900	20	433,0	200	659	0,84	4650	606,2	280,0	922	3500	0,95

Tmax/Tn=2.2		J=0.63Kgm ²		S1					S6/40%				
Poles: 6													
VOLT	HZ	RPM	slip	L _{arm}	KW	Nm	cosφ	const. power max RPM	L _{arm}	KW	Nm	const. power max RPM	Rend S1
400	47,9	930	28	155,0	81	836	0,84	1500	217,0	114	1170	1150	0,90
400	65,8	1290	26	206,0	110	815	0,85	2100	288,4	154	1141	1600	0,92
400	86,3	1700	26	254,0	139	778	0,85	2750	355,6	194	1090	2050	0,94
400	124,2	2460	24	335,0	184	714	0,84	3950	469,0	258	1000	3000	0,95
400	137,9	2740	18	360,0	196	683	0,84	4400	504,0	274	957	3300	0,94
400	153,7	3050	24	385,0	210	659	0,84	4900	539,0	294	922	3700	0,95

Tmax/Tn=2.2		J=0.63Kgm ²		S1					S6/40%				
Poles: 6													
VOLT	HZ	RPM	slip	L _{arm}	KW	Nm	cosφ	const. power max RPM	L _{arm}	KW	Nm	const. power max RPM	Rend S1
460	45,8	890	26	128,0	77	826	0,84	1450	179,3	107,8	1157	1100	0,90
460	64,0	1260	20	173,4	107	811	0,85	2050	242,8	149,8	1136	1550	0,92
460	86,0	1700	20	217,8	137	770	0,85	2750	304,9	191,8	1078	2050	0,94
460	121,0	2400	20	281,5	178	708	0,84	3850	394,1	249,2	992	2900	0,95
460	144,5	2870	20	314,9	198	659	0,84	4600	440,8	277,2	922	3450	0,95

Note: Speed values must be technically compatible with bearings type and applied accessories

TETRAVEC 200L.3

S6 VERSION POWER DERATING: -5% ($T_{max}/T_n=1.5$)

Tmax/Tn=2.2		J=0.75Kgm ²		S1					S6/40%				
Poles: 6													
VOLT	HZ	RPM	slip	L _{arm}	KW	Nm	cosφ	const. power max RPM	L _{arm}	KW	Nm	const. power max RPM	Rend S1
380	38,2	745	19	153,0	75	962	0,85	1200	214,2	105,0	1346	900	0,88
330	38,2	745	19	176,0	75	962	0,85	1200	246,4	105,0	1346	900	0,88
380	57,3	1120	26	225,0	112	955	0,83	1800	315,0	156,8	1337	1350	0,91
342	57,3	1120	26	250,0	112	955	0,83	1800	350,0	156,8	1337	1350	0,91
380	65,0	1280	20	250,0	125	933	0,83	2050	350,0	175,0	1306	1550	0,92
380	76,2	1500	24	284,0	145	923	0,84	2400	397,6	203,0	1293	1800	0,93
330	76,2	1500	24	326,0	145	923	0,84	2400	456,4	203,0	1293	1800	0,93
380	108,0	2140	20	365,0	190	848	0,84	3450	511,0	266,0	1187	2600	0,94
342	108,0	2140	20	406,0	190	848	0,84	3450	568,4	266,0	1187	2600	0,94
380	121,5	2410	20	396,0	205	812	0,84	3900	554,4	287,0	1137	2900	0,94
380	138,0	2740	20	434,0	225	784	0,84	4400	607,6	315,0	1098	3300	0,94
333	138,0	2740	20	495,0	225	784	0,84	4400	693,0	315,0	1098	3300	0,94

Tmax/Tn=2.2		J=0.75Kgm ²		S1					S6/40%				
Poles: 6													
VOLT	HZ	RPM	slip	L _{arm}	KW	Nm	cosφ	const. power max RPM	L _{arm}	KW	Nm	const. power max RPM	Rend S1
400	40,2	780	24	153,0	79	962	0,85	1250	214,2	110	1346	950	0,88
400	60,3	1180	26	225,0	118	955	0,83	1900	315,0	165	1337	1400	0,91
400	80,2	1580	24	284,0	153	923	0,84	2550	397,6	214	1293	1900	0,93
400	113,7	2250	24	365,0	200	848	0,84	3650	511,0	280	1187	2750	0,94
400	127,9	2540	18	396,0	216	812	0,84	4100	554,4	302	1137	3050	0,94
400	145,3	2880	25	434,0	237	784	0,84	4650	607,6	331	1098	3450	0,94

Tmax/Tn=2.2		J=0.75Kgm ²		S1					S6/40%				
Poles: 6													
VOLT	HZ	RPM	slip	L _{arm}	KW	Nm	cosφ	const. power max RPM	L _{arm}	KW	Nm	const. power max RPM	Rend S1
460	38,5	750	20	126,4	75	955	0,85	1200	176,9	105,0	1337	900	0,88
460	58,0	1140	20	189,2	114	955	0,83	1850	264,9	159,6	1337	1400	0,91
460	120,0	2380	20	320,6	202	811	0,84	3850	448,8	282,8	1135	2900	0,94
460	135,0	2680	20	350,6	220	784	0,84	4300	490,8	308,0	1098	3250	0,94

Note: Speed values must be technically compatible with bearings type and applied accessories

TETRAVEC 200L.4

S6 VERSION POWER DERATING: -5% (Tmax/Tn=1.4)

Tmax/Tn=2.3		J=0.90Kgm ²		S1					S6/40%				
Poles: 6													
VOLT	HZ	RPM	slip	L _{arm}	KW	Nm	cosφ	const. power max RPM	L _{arm}	KW	Nm	const. power max RPM	Rend S1
380	39,4	760	28	187,0	91	1144	0,84	1300	261,8	127,4	1601	950	0,88
348	39,4	760	28	204,0	91	1144	0,84	1300	285,6	127,4	1601	950	0,89
380	60,5	1180	30	282,0	141	1141	0,83	1950	394,8	197,4	1598	1500	0,92
330	60,5	1180	30	324,0	141	1141	0,83	1950	453,6	197,4	1598	1500	0,92
380	77,0	1520	20	347,0	176	1106	0,83	2550	485,8	246,4	1548	1900	0,93
345	77,0	1520	20	382,0	176	1106	0,83	2550	534,8	246,4	1548	1900	0,93
380	87,5	1730	20	382,0	195	1077	0,84	2900	534,8	273,0	1507	2150	0,93
342	87,5	1730	20	425,0	195	1077	0,84	2900	595,0	273,0	1507	2150	0,93
380	113,5	2250	20	437,0	223	947	0,83	3750	611,8	312,2	1325	2800	0,94
332	113,5	2250	20	500,0	223	947	0,83	3750	700,0	312,2	1325	2800	0,94

Tmax/Tn=2.3		J=0.90Kgm ²		S1					S6/40%				
Poles: 6													
VOLT	HZ	RPM	slip	L _{arm}	KW	Nm	cosφ	const. power max RPM	L _{arm}	KW	Nm	const. power max RPM	Rend S1
400	41,5	800	29	187,0	96	1144	0,84	1350	261,8	134	1601	1000	0,88
400	63,7	1240	34	282,0	148	1141	0,83	2050	394,8	207	1598	1600	0,92
400	81,1	1600	21	347,0	185	1106	0,83	2700	485,8	259	1548	2000	0,93
400	104,2	2060	24	400,0	215	999	0,83	3400	560,0	302	1399	2600	0,94
400	119,5	2370	19	437,0	235	947	0,83	3950	611,8	329	1325	2950	0,94

Tmax/Tn=2.3		J=0.90Kgm ²		S1					S6/40%				
Poles: 6													
VOLT	HZ	RPM	slip	L _{arm}	KW	Nm	cosφ	const. power max RPM	L _{arm}	KW	Nm	const. power max RPM	Rend S1
460	38,1	740	22	149,4	88	1136	0,84	1250	209,1	123,2	1590	950	0,88
460	58,5	1150	20	226,3	137	1138	0,83	1900	316,9	191,8	1593	1450	0,92
460	74,5	1470	20	276,9	170	1105	0,83	2450	387,6	238,0	1546	1850	0,93
460	110,0	2180	20	349,7	216	946	0,83	3600	489,5	302,4	1325	2750	0,94

Note: Speed values must be technically compatible with bearings type and applied accessories

TETRAVEC 200L.5

NOT AVAILABLE S6 VERSION

Tmax/Tn=2.4		J=1.14Kgm ²		S1					S6/40%				
Poles: 6													
VOLT	HZ	RPM	slip	L _{arm}	KW	Nm	cosφ	const. power max RPM	L _{arm}	KW	Nm	const. power max RPM	Rend S1
380	38,5	740	30	212,0	103	1329	0,84	1300	296,8	144,2	1861	950	0,88
342	38,5	740	30	235,0	103	1329	0,84	1300	329,0	144,2	1861	950	0,89
380	48,5	950	20	262,0	130	1307	0,83	1650	366,8	182,0	1830	1200	0,91
330	48,5	950	20	300,0	130	1307	0,83	1650	420,0	182,0	1830	1200	0,92
380	56,5	1100	30	300,0	150	1302	0,83	1900	420,0	210,0	1823	1400	0,92
380	68,5	1350	20	360,0	180	1273	0,83	2300	504,0	252,0	1783	1700	0,92
342	68,5	1350	20	400,0	180	1273	0,83	2300	560,0	252,0	1783	1700	0,92
380	86,0	1700	20	444,0	225	1264	0,84	2900	621,6	315,0	1770	2150	0,92
330	86,0	1700	20	512,0	225	1264	0,84	2900	716,8	315,0	1770	2150	0,92
380	103,0	2040	20	487,0	245	1147	0,83	3500	681,8	343,0	1606	2550	0,93

Tmax/Tn=2.4		J=1.14Kgm ²		S1					S6/40%				
Poles: 6													
VOLT	HZ	RPM	slip	L _{arm}	KW	Nm	cosφ	const. power max RPM	L _{arm}	KW	Nm	const. power max RPM	Rend S1
400	40,5	780	31	212,0	109	1329	0,84	1350	296,8	152	1861	1000	0,88
400	51,1	1000	21	262,0	137	1307	0,83	1750	366,8	192	1830	1250	0,91
400	59,5	1160	29	300,0	158	1302	0,83	2000	420,0	222	1823	1450	0,92
400	90,5	1790	21	444,0	237	1264	0,84	3050	621,6	332	1770	2250	0,92
400	108,4	2150	18	487,0	258	1147	0,83	3700	681,8	362	1606	2700	0,93

Tmax/Tn=2.4		J=1.14Kgm ²		S1					S6/40%				
Poles: 6													
VOLT	HZ	RPM	slip	L _{arm}	KW	Nm	cosφ	const. power max RPM	L _{arm}	KW	Nm	const. power max RPM	Rend S1
460	38,9	750	28	176,4	104	1324	0,84	1300	247,0	145,6	1854	950	0,89
460	59,3	1160	26	264,5	158	1301	0,83	2000	370,2	221,2	1821	1450	0,91
460	75,5	1490	20	323,5	197	1263	0,83	2550	452,9	275,8	1768	1900	0,92
460	109,0	2160	20	419,8	260	1150	0,84	3700	587,8	364,0	1610	2700	0,93
460	126,0	2500	20	477,4	295	1127	0,83	4250	668,4	413,0	1578	3150	0,94

Note: Speed values must be technically compatible with bearings type and applied accessories

Other windings on request

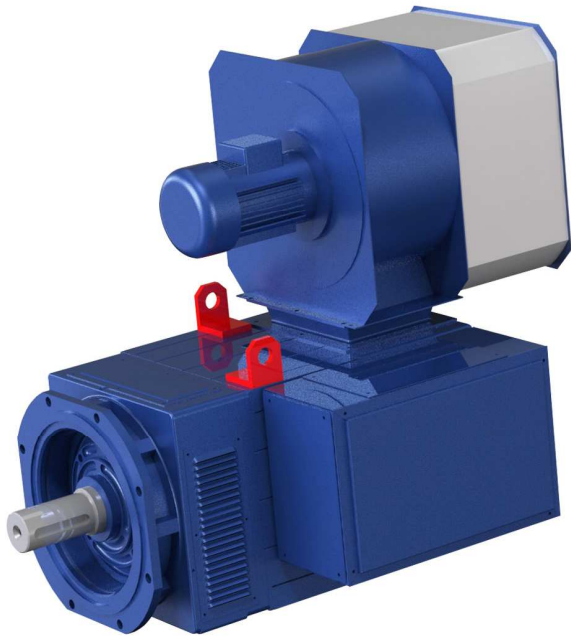

IP PROTECTION	IP23
THERMAL PROTECTION TYPE	KLIXON (PT100, PTC on request)
BALANCING, VIBRATION GRADE (EN 60034-14 / VDE 0530 part 14)	A (B on request)
INSULATION CLASS	F
COOLING METHOD	IC06 (with filter on request)
STANDARD FAN DETAILS	3x230/400Vac 50Hz 11,5/6,6A
Amb. Cond.	0 + 40°C (32 + 104°F) 1000m ASL
TRANSDUCER	ENCODER OR RESOLVER (on request)
MOUNTING FORM	B3, B35, or other on request
BRAKE	up to 2400 Nm (on request)
DE BEARING	BALL (ROLLER on request)
NDE BEARING	BALL (insulated on request)
MAX MECHANICAL SPEED	3500 r.p.m. (3000 r.p.m. roller bearing) 6000 r.p.m. (S6 version)
PAINTING SYSTEM	NITRO, POLYURETHANIC, C5M, on request

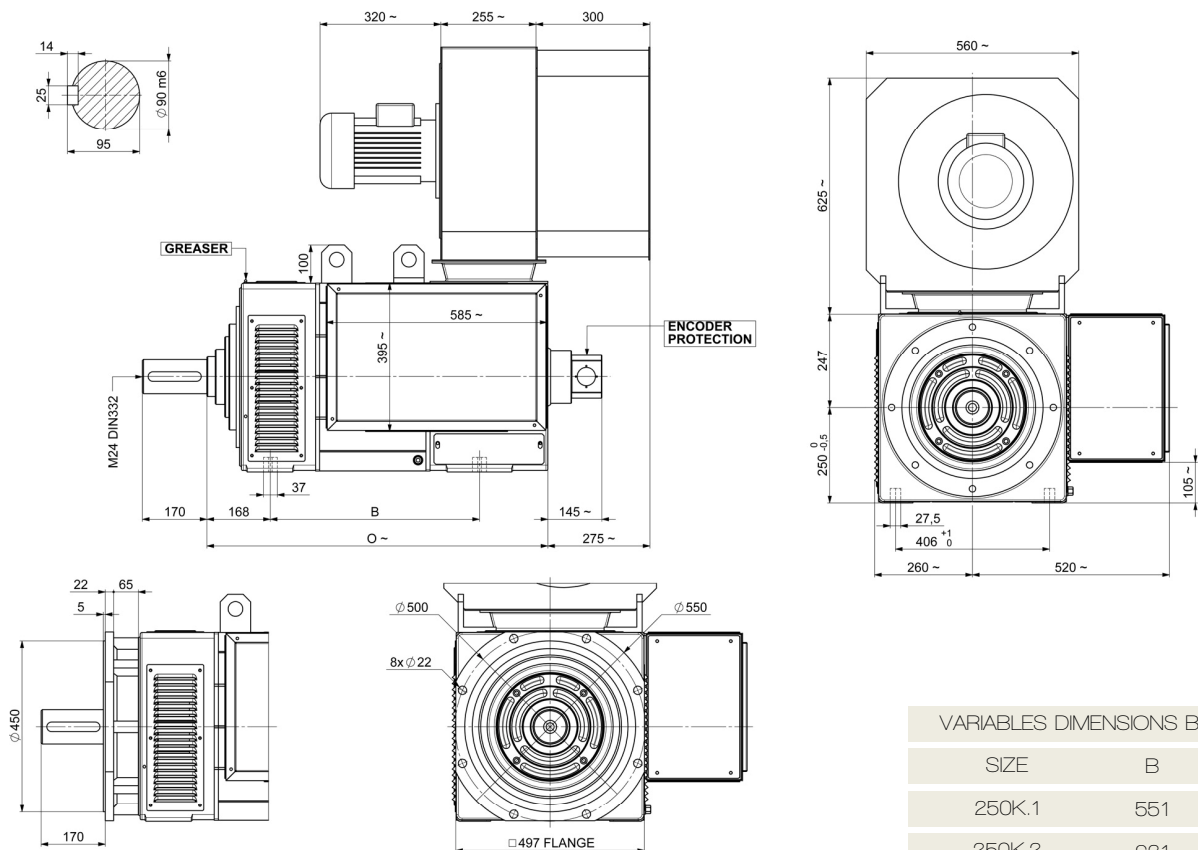

VARIABLES DIMENSIONS BY SIZE		
SIZE	B	O
250K.1	551	900
250K.2	621	970
250K.3	711	1060
250K.4	831	1180
250K.5	971	1320

unit [mm]

TETRAVEC 250K.1

S6 VERSION POWER DERATING: -5%

Poles: 6 Al version												
Tmax/Tn=2.4 J=2.0Kgm ²			S1						S6/40%			
VOLT	HZ	RPM	L _{arm}	KW	Nm	cosφ	const. power max RPM	Eff. S1	L _{arm}	KW	Nm	const. power max RPM
400	51,3	1.010	275	143	1.355	0,83	2.200	0,91	385	205	1.940	1.650
400	69,3	1.370	365	191	1.335	0,83	2.950	0,92	515	270	1.885	2.200
400	84,3	1.670	430	228	1.305	0,83	3.600	0,93	605	320	1.835	2.700
400	108,3	2.150	520	283	1.260	0,84	4.500	0,93	730	400	1.780	3.450
400	128,3	2.550	605	330	1.240	0,84	4.500	0,94	850	465	1.745	4.100
460	58,8	1.160	275	164	1.355	0,83	2.500	0,91	385	235	1.935	1.900
460	79,8	1.580	365	220	1.330	0,83	3.400	0,92	515	310	1.875	2.550
460	96,8	1.920	430	262	1.305	0,83	4.150	0,93	605	370	1.845	3.100
460	124,8	2.480	520	325	1.255	0,84	4.500	0,93	730	460	1.775	4.000
460	147,8	2.940	605	380	1.235	0,84	4.500	0,94	850	535	1.740	4.500

TETRAVEC 250KC.1

NOT AVAILABLE IN S6 VERSION

Poles: 6 Cu version												
Tmax/Tn=2.3 J=2.6Kgm ²			S1						S6/40%			
VOLT	HZ	RPM	L _{arm}	KW	Nm	cosφ	const. power max RPM	Eff. S1	L _{arm}	KW	Nm	const. power max RPM
400	51,0	1.010	290	152	1.440	0,83	2.200	0,92	410	215	2.035	1.650
400	69,0	1.370	385	205	1.430	0,84	2.950	0,92	540	290	2.025	2.200
400	84,0	1.670	460	245	1.405	0,83	3.500	0,93	645	345	1.975	2.700
400	108,0	2.150	555	304	1.355	0,84	3.500	0,94	780	430	1.915	3.450
400	128,0	2.550	635	350	1.315	0,85	3.500	0,95	890	490	1.840	3.500
460	58,5	1.160	290	175	1.440	0,83	2.500	0,92	410	245	2.020	1.900
460	79,5	1.580	385	236	1.425	0,84	3.400	0,92	540	335	2.025	2.550
460	96,5	1.920	460	282	1.405	0,83	3.500	0,93	645	395	1.970	3.100
460	124,5	2.480	555	350	1.350	0,84	3.500	0,94	780	490	1.890	3.500
460	147,5	2.940	635	403	1.310	0,85	3.500	0,95	890	565	1.840	3.500

Note: Speed values must be technically compatible with bearings type and applied accessories

TETRAVEC 250K.2

S6 VERSION POWER DERATING: -5% (Tmax/Tn=2.2)

Poles: 6 Al version												
Tmax/Tn=2.5 J=2.5Kgm ²			S1						S6/40%			
VOLT	HZ	RPM	L _{arm}	KW	Nm	cosφ	const. power max RPM	Eff. S1	L _{arm}	KW	Nm	const. power max RPM
400	47,2	930	305	160	1.645	0,83	2.000	0,91	430	225	2.315	1.500
400	67,7	1.340	425	226	1.615	0,83	2.900	0,92	595	320	2.285	2.150
400	84,2	1.670	520	278	1.595	0,84	3.600	0,93	730	390	2.235	2.700
400	101,7	2.020	595	325	1.540	0,84	4.450	0,93	835	455	2.155	3.250
400	124,2	2.470	710	388	1.505	0,84	4.500	0,94	995	545	2.110	4.000
460	54,2	1.070	305	184	1.645	0,83	2.350	0,91	430	260	2.320	1.750
460	77,7	1.540	425	260	1.615	0,83	3.350	0,92	595	365	2.265	2.500
460	96,7	1.920	520	320	1.595	0,84	4.150	0,93	730	450	2.240	3.100
460	117,2	2.330	595	374	1.535	0,84	4.500	0,93	835	525	2.155	3.750
460	143,2	2.850	710	446	1.500	0,84	4.500	0,94	995	625	2.095	4.500

TETRAVEC 250KC.2

NOT AVAILABLE IN S6 VERSION

Poles: 6 Cu version												
Tmax/Tn=2.4 J=3.2Kgm ²			S1						S6/40%			
VOLT	HZ	RPM	L _{arm}	KW	Nm	cosφ	const. power max RPM	Eff. S1	L _{arm}	KW	Nm	const. power max RPM
400	47,0	930	325	172	1.770	0,83	2.000	0,92	455	245	2.520	1.500
400	67,5	1.340	450	243	1.735	0,84	2.900	0,93	630	345	2.460	2.150
400	84,0	1.670	555	300	1.720	0,84	3.500	0,93	780	420	2.405	2.700
400	101,5	2.020	635	348	1.650	0,84	3.500	0,94	890	490	2.320	3.250
400	124,0	2.470	745	412	1.595	0,85	3.500	0,95	1.045	580	2.245	3.500
460	54,0	1.070	325	198	1.770	0,83	2.350	0,92	455	280	2.500	1.750
460	77,5	1.540	450	279	1.735	0,84	3.350	0,93	630	395	2.450	2.500
460	96,5	1.920	555	345	1.720	0,84	3.500	0,93	780	485	2.415	3.100
460	117,0	2.330	635	400	1.645	0,84	3.500	0,94	890	565	2.320	3.500
460	143,0	2.850	745	474	1.590	0,85	3.500	0,95	1.045	665	2.230	3.500

Note: Speed values must be technically compatible with bearings type and applied accessories

TETRAVEC 250K.3

S6 VERSION POWER DERATING: -5% ($T_{max}/T_n=1.7$)

Poles: 6 Al version												
T _{max} /T _n =2.5 J=3.1Kgm ²			S1						S6/40%			
VOLT	HZ	RPM	L _{arm}	KW	Nm	cosφ	const. power max RPM	Eff. S1	L _{arm}	KW	Nm	const. power max RPM
400	37,7	740	305	160	2.070	0,83	1.600	0,91	430	225	2.905	1.200
400	57,7	1.140	455	240	2.015	0,83	2.500	0,92	640	340	2.850	1.850
400	77,7	1.540	605	323	2.005	0,83	3.350	0,93	850	455	2.825	2.500
400	96,7	1.920	715	390	1.945	0,84	4.250	0,94	1.005	550	2.740	3.100
400	124,2	2.470	865	475	1.840	0,84	4.500	0,94	1.215	665	2.575	4.000
460	43,2	850	305	184	2.070	0,83	1.850	0,91	430	260	2.925	1.400
460	66,2	1.310	455	276	2.015	0,83	2.850	0,92	640	390	2.845	2.100
460	89,2	1.770	605	371	2.005	0,83	3.850	0,93	850	525	2.835	2.850
460	111,2	2.210	715	449	1.940	0,84	4.500	0,94	1.005	630	2.725	3.550
460	142,7	2.840	865	546	1.840	0,84	4.500	0,94	1.215	765	2.575	4.500

TETRAVEC 250KC.3

NOT AVAILABLE IN S6 VERSION

Poles: 6 Cu version												
T _{max} /T _n =2.4 J=3.9Kgm ²			S1						S6/40%			
VOLT	HZ	RPM	L _{arm}	KW	Nm	cosφ	const. power max RPM	Eff. S1	L _{arm}	KW	Nm	const. power max RPM
400	37,5	740	325	172	2.225	0,83	1.600	0,92	455	245	3.165	1.200
400	57,5	1.140	490	260	2.180	0,83	2.500	0,92	690	365	3.060	1.850
400	77,5	1.540	640	345	2.145	0,84	3.350	0,93	900	485	3.010	2.500
400	96,5	1.920	750	414	2.060	0,85	3.500	0,94	1.050	580	2.890	3.100
400	124,0	2.470	920	510	1.975	0,85	3.500	0,95	1.290	715	2.765	3.500
460	43,0	850	325	198	2.225	0,83	1.850	0,92	455	280	3.150	1.400
460	66,0	1.310	490	299	2.180	0,83	2.850	0,92	690	420	3.065	2.100
460	89,0	1.770	640	397	2.145	0,84	3.500	0,93	900	560	3.025	2.850
460	111,0	2.210	750	476	2.060	0,85	3.500	0,94	1.050	670	2.900	3.500
460	142,5	2.840	920	587	1.975	0,85	3.500	0,95	1.290	825	2.775	3.500

Note: Speed values must be technically compatible with bearings type and applied accessories

TETRAVEC 250K.4

S6 VERSION POWER DERATING: -5% (Tmax/Tn=1.4)

Poles: 6 Al version												
Tmax/Tn=2.7 J=3.9Kgm ²			S1						S6/40%			
VOLT	HZ	RPM	L _{arm}	KW	Nm	cosφ	const. power max RPM	Eff. S1	L _{arm}	KW	Nm	const. power max RPM
400	38,1	750	370	197	2.510	0,84	1.650	0,92	520	280	3.570	1.200
400	56,6	1.120	545	292	2.495	0,84	2.450	0,92	765	410	3.500	1.800
400	74,1	1.470	700	378	2.460	0,84	3.200	0,93	980	530	3.445	2.400
400	95,6	1.900	845	460	2.315	0,84	4.200	0,93	1.185	645	3.245	3.050
400	111,6	2.220	940	515	2.220	0,84	4.500	0,94	1.320	725	3.120	3.600
460	43,6	860	370	227	2.520	0,84	1.850	0,92	520	320	3.560	1.400
460	65,1	1.290	545	336	2.490	0,84	2.800	0,92	765	475	3.520	2.100
460	85,1	1.690	700	435	2.460	0,84	3.650	0,93	980	610	3.450	2.750
460	110,1	2.190	845	529	2.310	0,84	4.500	0,93	1.185	745	3.250	3.550
460	128,6	2.560	940	592	2.210	0,84	4.500	0,94	1.320	830	3.100	4.100

TETRAVEC 250KC.4

NOT AVAILABLE IN S6 VERSION

Poles: 6 Cu version												
Tmax/Tn=2.6 J=4.9Kgm ²			S1						S6/40%			
VOLT	HZ	RPM	L _{arm}	KW	Nm	cosφ	const. power max RPM	Eff. S1	L _{arm}	KW	Nm	const. power max RPM
400	38,0	750	400	213	2.715	0,84	1.650	0,93	560	300	3.825	1.200
400	56,5	1.120	580	315	2.690	0,84	2.450	0,93	815	445	3.795	1.800
400	74,0	1.470	750	409	2.660	0,85	3.200	0,94	1.050	575	3.740	2.400
400	95,5	1.900	900	495	2.490	0,85	3.500	0,94	1.260	695	3.495	3.050
400	111,5	2.220	1.005	556	2.395	0,85	3.500	0,95	1.410	780	3.360	3.500
460	43,5	860	400	245	2.720	0,84	1.850	0,93	560	345	3.835	1.400
460	65,0	1.290	580	362	2.685	0,84	2.800	0,93	815	510	3.780	2.100
460	85,0	1.690	750	470	2.660	0,85	3.500	0,94	1.050	660	3.735	2.750
460	110,0	2.190	900	569	2.485	0,85	3.500	0,94	1.260	800	3.490	3.500
460	128,5	2.560	1.005	639	2.390	0,85	3.500	0,95	1.410	900	3.360	3.500

Note: Speed values must be technically compatible with bearings type and applied accessories

TETRAVEC 250K.5

NOT AVAILABLE IN S6 VERSION

Poles: 6 Al version												
Tmax/Tn=2.8 J=4.8Kgm ²			S1						S6/40%			
VOLT	HZ	RPM	L _{arm}	KW	Nm	cosφ	const. power max RPM	Eff. S1	L _{arm}	KW	Nm	const. power max RPM
400	36,6	720	430	228	3.030	0,84	1.550	0,92	605	320	4.245	1.200
400	53,6	1.060	625	334	3.010	0,84	2.300	0,92	875	470	4.235	1.700
400	74,6	1.480	845	458	2.960	0,84	3.200	0,93	1.185	645	4.165	2.400
400	85,6	1.700	965	522	2.935	0,84	3.750	0,93	1.355	735	4.130	2.750
400	102,6	2.040	1.080	590	2.765	0,84	4.500	0,94	1.515	830	3.890	3.300
460	42,1	830	430	262	3.020	0,84	1.800	0,92	605	370	4.260	1.350
460	61,6	1.220	625	384	3.010	0,84	2.650	0,92	875	540	4.230	2.000
460	85,6	1.700	845	527	2.960	0,84	3.700	0,93	1.185	740	4.160	2.750
460	98,6	1.960	965	600	2.930	0,84	4.350	0,93	1.355	845	4.120	3.150
460	118,1	2.350	1.080	679	2.760	0,84	4.500	0,94	1.515	950	3.865	3.800

TETRAVEC 250KC.5

NOT AVAILABLE IN S6 VERSION

Poles: 6 Cu version												
Tmax/Tn=2.7 J=5.8Kgm ²			S1						S6/40%			
VOLT	HZ	RPM	L _{arm}	KW	Nm	cosφ	const. power max RPM	Eff. S1	L _{arm}	KW	Nm	const. power max RPM
400	36,5	720	470	253	3.360	0,84	1.550	0,93	660	355	4.710	1.200
400	53,5	1.060	685	372	3.355	0,84	2.300	0,94	960	525	4.735	1.700
400	74,5	1.480	915	500	3.230	0,84	3.200	0,94	1.285	700	4.520	2.400
400	85,5	1.700	1.035	568	3.195	0,84	3.500	0,94	1.450	800	4.495	2.750
400	102,5	2.040	1.165	642	3.010	0,84	3.500	0,94	1.635	900	4.215	3.300
460	42,0	830	470	291	3.355	0,84	1.800	0,93	660	410	4.725	1.350
460	61,5	1.220	685	428	3.350	0,84	2.650	0,94	960	600	4.700	2.000
460	85,5	1.700	915	575	3.230	0,84	3.500	0,94	1.285	805	4.525	2.750
460	98,5	1.960	1.035	653	3.185	0,84	3.500	0,94	1.450	915	4.460	3.150
460	118,0	2.350	1.165	738	3.005	0,84	3.500	0,94	1.635	1035	4.210	3.500

Note: Speed values must be technically compatible with bearings type and applied accessories

Other windings on request

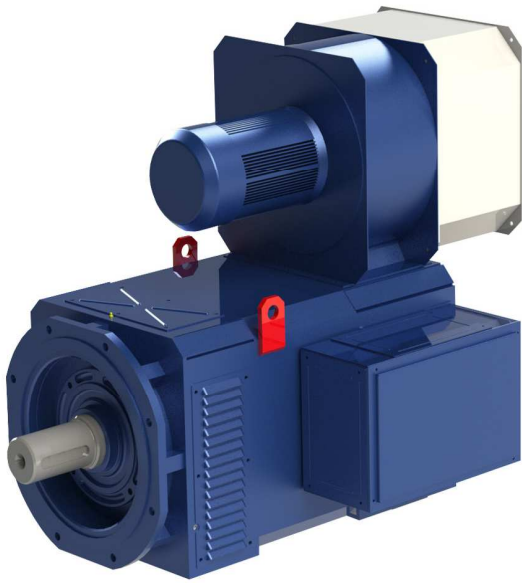

IP PROTECTION	IP23
THERMAL PROTECTION TYPE	KLIXON (PT100, PTC on request)
BALANCING, VIBRATION GRADE (EN 60034-14 / VDE 0530 part 14)	A (B on request)
INSULATION CLASS	F
COOLING METHOD	IC06 (with filter on request)
STANDARD FAN DETAILS	3x230/400Vac 50Hz 19,6/11,3A
Amb. Cond.	0 + 40°C (32 + 104°F) 1000m ASL
TRANSDUCER	ENCODER OR RESOLVER (on request)
MOUNTING FORM	B3, B35, or other on request
BRAKE	up to 2500 Nm (on request)
DE BEARING	BALL (ROLLER on request)
NDE BEARING	BALL (INSULATED)
MAX MECHANICAL SPEED	3200 r.p.m. (2400 r.p.m. roller bearing) 4500 r.p.m. (S6 version)
PAINTING SYSTEM	NITRO, POLYURETHANIC, C5M, on request

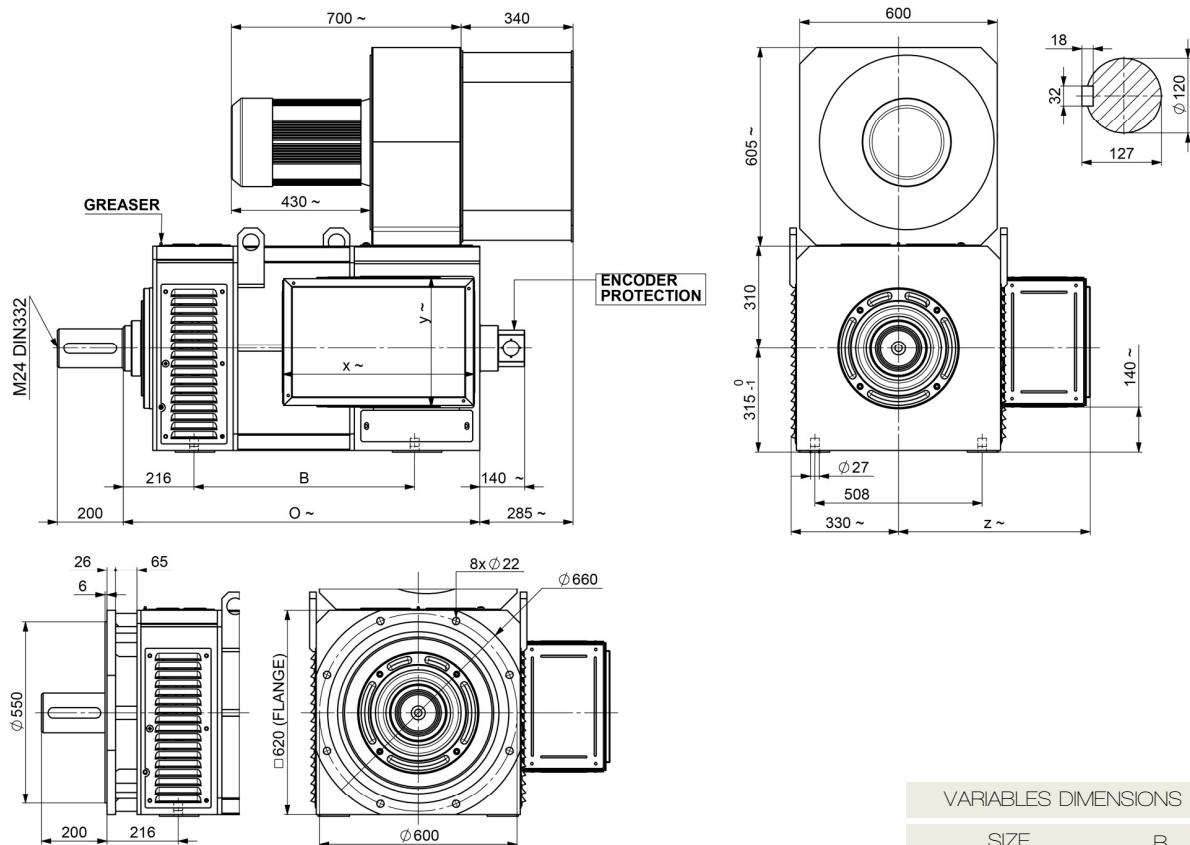

TERMINAL BOX DIMENSIONS			
MOTOR CURRENT	x	y	z
TILL 1500 A	585	400	585
OVER 1500 A	645	534	585

VARIABLES DIMENSIONS BY SIZE		
SIZE	B	O
315L.1	670	1090
315L.2	780	1200
315L.3	900	1320
315L.4	1030	1450
315L.5	1190	1610

unit [mm]

GENERAL DATA

S6 VERSION POWER DERATING: -12%, 315L.5 NOT AVAILABLE IN S6 VERSION

SUPPLY VOLTAGE 690V							Poles: 6		
TYPE	TORQUE Nm	POWER Kw	SPEED rpm	VOLTAGE V	CURRENT A	J Kgm ²	COS ϕ	EFF.	
315L.1	3.500	205	560	690	225	8,0	0,89	0,86	RPM 500
315L.2	4.500	245	520	690	270	10,4	0,89	0,86	
315L.3	5.550	315	540	690	343	12,8	0,89	0,87	
315L.4	6.700	345	490	690	374	15,6	0,89	0,87	
315L.5	8.100	440	520	690	470	18,8	0,89	0,88	
315L.1	3.450	360	1000	690	390	8,0	0,86	0,91	RPM 1000
315L.2	4.450	460	990	690	492	10,4	0,86	0,91	
315L.3	5.550	580	1000	690	618	12,8	0,87	0,91	
315L.4	6.700	700	1000	690	735	15,6	0,87	0,92	
315L.5	8.050	775	920	690	800	18,8	0,87	0,93	
315L.1	3.400	545	1540	690	575	8,0	0,85	0,94	RPM 1500
315L.2	4.400	715	1560	690	755	10,4	0,85	0,94	
315L.3	5.500	915	1590	690	955	12,8	0,86	0,95	
315L.4	6.650	1.100	1580	690	1130	15,6	0,86	0,95	
315L.5	7.950	1.350	1620	690	1385	18,8	0,86	0,95	

SUPPLY VOLTAGE 460V							Poles: 6		
TYPE	TORQUE Nm	POWER Kw	SPEED rpm	VOLTAGE V	CURRENT A	J Kgm ²	COS ϕ	EFF.	
315L.1	3.500	215	590	460	355	8,0	0,89	0,86	RPM 500
315L.2	4.500	265	560	460	435	10,4	0,89	0,86	
315L.3	5.600	300	510	460	490	12,8	0,89	0,87	
315L.4	6.700	345	490	460	560	15,6	0,89	0,87	
315L.5	8.100	440	520	460	708	18,8	0,89	0,88	
315L.1	3.450	375	1040	460	605	8,0	0,86	0,91	RPM 1000
315L.2	4.450	475	1020	460	765	10,4	0,86	0,91	
315L.3	5.550	565	970	460	900	12,8	0,87	0,91	
315L.4	6.700	720	1030	460	1140	15,6	0,87	0,92	
315L.5	8.050	790	940	460	1230	18,8	0,87	0,93	
315L.1	3.400	545	1540	460	860	8,0	0,85	0,94	RPM 1500
315L.2	4.400	715	1560	460	1130	10,4	0,85	0,94	
315L.3	5.450	915	1600	460	1430	12,8	0,86	0,95	
315L.4	6.650	1.055	1510	460	1620	15,6	0,86	0,95	
315L.5	8.000	1.205	1440	460	1850	18,8	0,86	0,95	

Note: Speed values must be technically compatible with bearings type and applied accessories

GENERAL DATA

S6 VERSION POWER DERATING: -12%, 315L.5 NOT AVAILABLE IN S6 VERSION

SUPPLY VOLTAGE 400V							Poles: 6		
TYPE	TORQUE Nm	POWER Kw	SPEED rpm	VOLTAGE V	CURRENT A	J Kgm ²	COS ϕ	EFF.	
315L.1	3.500	210	570	400	395	8,0	0,89	0,86	500 RPM
315L.2	4.500	265	560	400	500	10,4	0,89	0,86	
315L.3	5.600	305	520	400	570	12,8	0,89	0,87	
315L.4	6.700	345	490	400	645	15,6	0,89	0,87	
315L.5	8.100	440	520	400	812	18,8	0,89	0,88	
315L.1	3.450	360	1000	400	670	8,0	0,86	0,91	1000 RPM
315L.2	4.450	465	1000	400	860	10,4	0,86	0,91	
315L.3	5.550	580	1000	400	1065	12,8	0,87	0,91	
315L.4	6.700	700	1000	400	1265	15,6	0,87	0,92	
315L.5	8.050	775	920	400	1385	18,8	0,87	0,93	
315L.1	3.400	545	1540	400	995	8,0	0,85	0,94	1500 RPM
315L.2	4.400	715	1560	400	1300	10,4	0,85	0,94	
315L.3	5.500	915	1590	400	1640	12,8	0,86	0,95	
315L.4	6.650	1.065	1530	400	1885	15,6	0,86	0,95	
315L.5	8.050	1.045	1240	400	1850	18,8	0,86	0,95	

Note: Speed values must be technically compatible with bearings type and applied accessories

Other windings on request

LIQUID COOLED ASYNCHRONOUS MOTORS

RELIABILITY
HIGH EFFICIENCY
VERY GOOD TORQUE/WEIGHT RATIO
VERY LOW NOISE LEVEL
SUITABLE FOR VECTOR DRIVES
IGBT COMPLIANT
WIDE RANGE OF CUSTOMIZATION AND
OPTIONS

TYPICAL APPLICATIONS

TUNNEL BORING MACHINES
FOOD BOXES EXTRUDERS
WINDERS AND UNWINDERS
LIFTING AND HANDLING SYSTEMS
PLASTIC AND RUBBER EXTRUDERS
PAPER AND CARDBOARD PRODUCTION
MACHINERY
PROCESSING AND CUTTING METAL PLATES
METAL WIRE PROCESSING MACHINERY
PACKAGING MACHINERY
MACHINE TOOLS
PRINTING MACHINERY
TEXTILE MACHINERY
COMPRESSORS
TRACTION CONTROL

IP PROTECTION **IP54 or IP55**
COOLING METHOD **LIQUID**

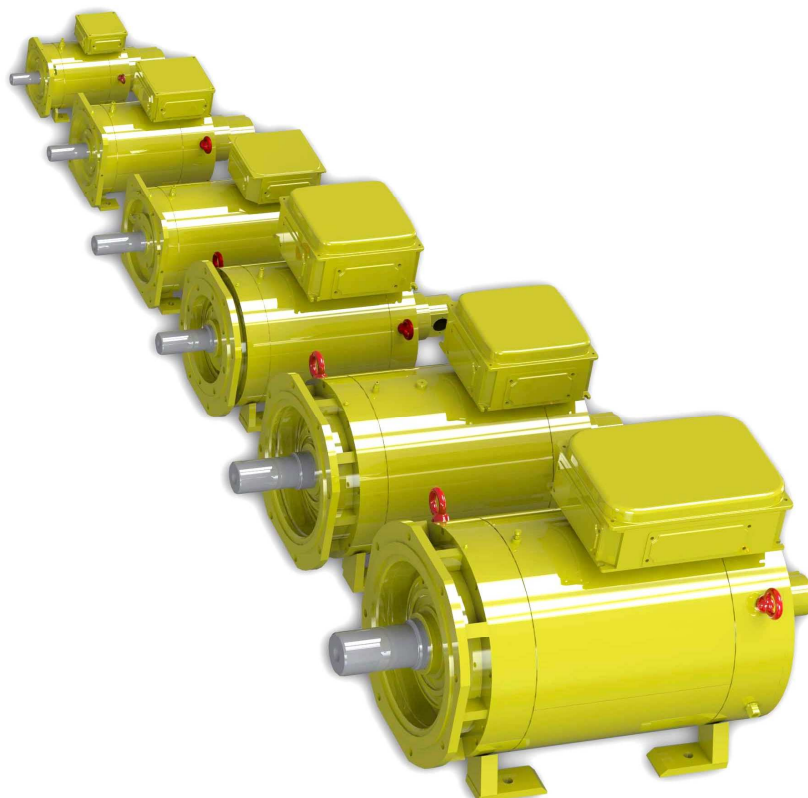

POWERTECH FLUID AX 100C

ASYNCHRONOUS MOTORS

OVERVIEW

Rev. 1.2

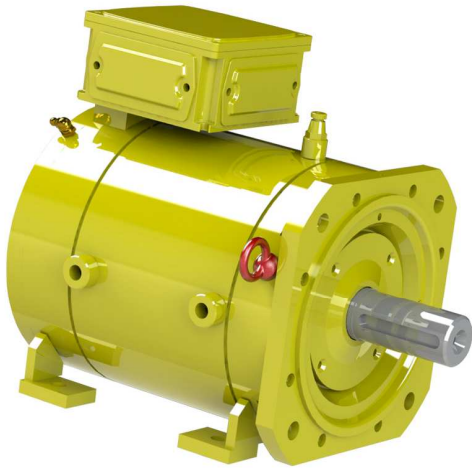

IP PROTECTION	IP54 (IP55 on request)
THERMAL PROTECTION TYPE	KLIXON (PT100, PTC on request)
BALANCING, VIBRATION GRADE (EN 60034-14 / VDE 0530 part 14)	A (B on request)
INSULATION CLASS	F
COOLING METHOD	8L/1' at 20°C (68°F) + GLYCOL 20%
Amb. Cond.	0 + 40°C (32 + 104°F) 1000m ASL
TRANSDUCER	ENCODER OR RESOLVER (on request)
MOUNTING FORM	B3, B35, or other on request
BRAKE	up to 95 Nm (on request)
DE BEARING	BALL (ROLLER on request)
NDE BEARING	ROLLER
MAX MECHANICAL SPEED	9000 r.p.m. (4500 r.p.m. roller bearing) 11000 r.p.m. (S4 version)
PAINTING SYSTEM	NITRO, POLYURETHANIC, C5M, on request

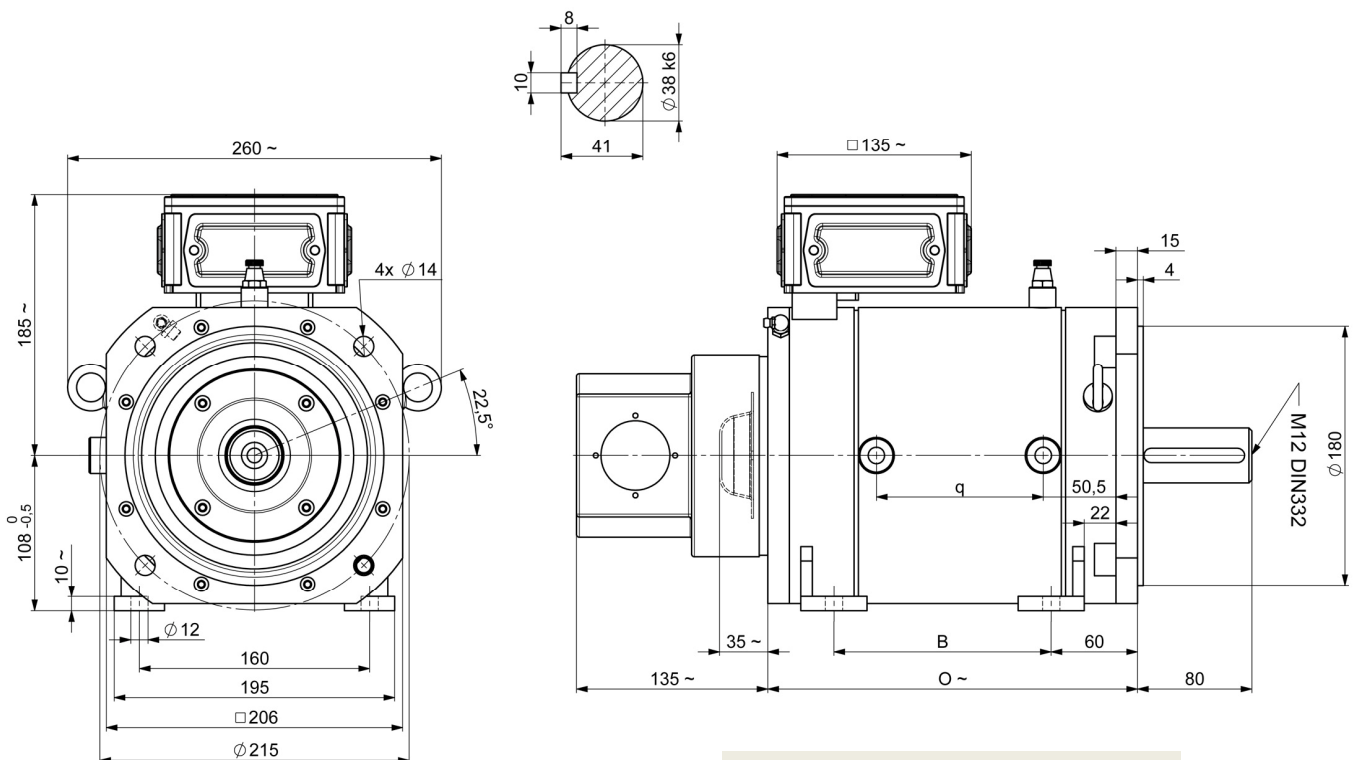

VARIABLES DIMENSIONS BY SIZE			
SIZE	B	O	q
100C.1	151	260	126
100C.2	176	285	151
100C.3	211	320	186
100C.4	261	370	236
100C.5	301	410	276
100C.6	346	455	321

unit [mm]

GENERAL DATA

S4 VERSION POWER DERATING: -5%

SUPPLY VOLTAGE 400V							Poles: 4		
TYPE	TORQUE Nm	POWER kW	SPEED rpm	VOLTAGE V	CURRENT A	J Kgm ²	COS ϕ	EFF.	
100C.1	33,6	3,5	1000	400	7,3	0,0062	0,80	0,87	1000 RPM
100C.2	45,6	4,8	1010	400	10	0,0075	0,80	0,88	
100C.3	56,5	6,0	1020	400	12,5	0,0102	0,80	0,88	
100C.4	77,4	8,3	1030	400	17,3	0,0142	0,80	0,88	
100C.5	90,8	10,0	1050	400	20,6	0,0168	0,80	0,89	
100C.6	109,9	12,5	1090	400	25,5	0,0198	0,80	0,89	
100C.1	32,0	5,1	1530	400	10,5	0,0062	0,80	0,89	1500 RPM
100C.2	43,3	7,0	1550	400	14,4	0,0075	0,80	0,89	
100C.3	54,5	8,8	1540	400	18	0,0102	0,80	0,89	
100C.4	74,7	12,0	1530	400	24,1	0,0142	0,80	0,90	
100C.5	87,9	14,5	1580	400	29,5	0,0168	0,80	0,90	
100C.6	106,7	17,1	1530	400	34,5	0,0198	0,80	0,90	
100C.1	31,1	6,5	2000	400	13,2	0,0062	0,80	0,89	2000 RPM
100C.2	41,8	8,9	2030	400	18	0,0075	0,80	0,89	
100C.3	52,4	11,2	2040	400	22,5	0,0102	0,80	0,90	
100C.4	72,1	15,8	2090	400	32	0,0142	0,80	0,90	
100C.5	84,4	18,7	2120	400	37	0,0168	0,81	0,91	
100C.6	103,0	23,2	2150	400	46	0,0198	0,81	0,91	

Note: Speed values must be technically compatible with bearings type and applied accessories

Other windings on request

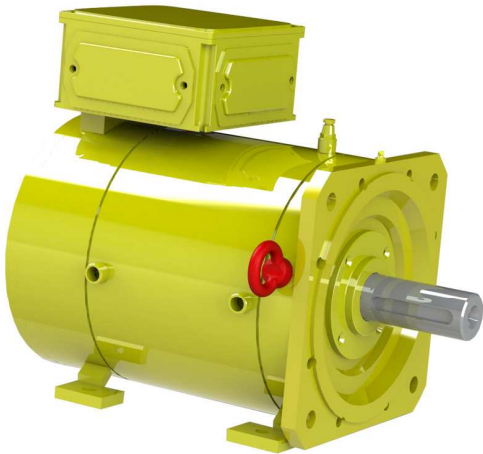

IP PROTECTION	IP54 (IP55 on request)
THERMAL PROTECTION TYPE	KLIXON (PT100, PTC on request)
BALANCING, VIBRATION GRADE (EN 60034-14 / VDE 0530 part 14)	A (B on request)
INSULATION CLASS	F
COOLING METHOD	12L/1' at 20°C (68°F) + GLYCOL 20%
Amb. Cond.	0 + 40°C (32 + 104°F) 1000m ASL
TRANSDUCER	ENCODER OR RESOLVER (on request)
MOUNTING FORM	B3, B35, or other on request
BRAKE	up to 300 Nm (on request)
DE BEARING	BALL (ROLLER on request)
NDE BEARING	ROLLER
MAX MECHANICAL SPEED	6500 r.p.m. (4000 r.p.m. roller bearing) 10000 r.p.m. (S4 version)
PAINTING SYSTEM	NITRO, POLYURETHANIC, C5M, on request

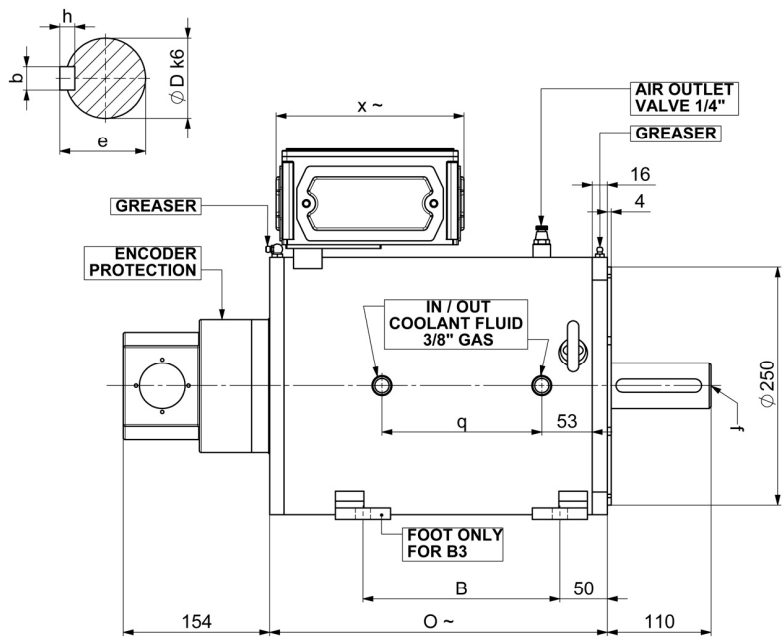
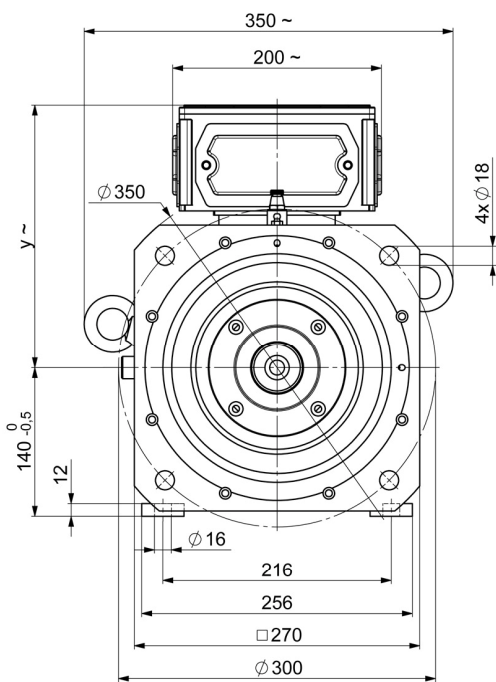

D	b x h	e	f
42 *	12x8	45	M12 DIN332
48	14x9	51,5	M16 DIN332

* OPTION

unit [mm]

VARIABLES DIMENSIONS BY SIZE					
SIZE	B	O	x	y	q
132C.1	207	355	200	250	168
132C.2	252	400	200	250	213
132C.3	287	435	265	300	248
132C.4	357	505	265	300	318
132C.5	427	575	265	300	388

GENERAL DATA

S4 VERSION POWER DERATING: -5%

SUPPLY VOLTAGE 400V							Poles: 4		
TYPE	TORQUE Nm	POWER kW	SPEED rpm	VOLTAGE V	CURRENT A	J Kgm ²	COS ϕ	EFF.	
132C.1	124	13,8	1060	400	28,8	0,042	0,85	81,9	1000 RPM
132C.2	168	19,0	1080	400	39	0,056	0,84	83,5	
132C.3	200	22,6	1080	400	45,7	0,067	0,84	84,9	
132C.4	268	30,0	1070	400	59,4	0,104	0,85	86,0	
132C.5	336	37,0	1050	400	73,2	0,130	0,84	86,5	
132C.1	120	19,0	1520	400	37,9	0,042	0,85	85,7	1500 RPM
132C.2	163	27,0	1580	400	52,7	0,056	0,85	87,3	
132C.3	193	32,0	1580	400	62,2	0,067	0,84	88,0	
132C.4	259	41,5	1530	400	80,4	0,104	0,84	88,7	
132C.5	325	52,0	1530	400	100,3	0,130	0,84	89,2	
132C.1	116	25,0	2050	400	45	0,042	0,84	87,8	2000 RPM
132C.2	157	34,0	2070	400	65,8	0,056	0,84	88,9	
132C.3	190	41,5	2090	400	79,8	0,067	0,84	89,4	
132C.4	251	55,0	2090	400	104,9	0,104	0,84	90,1	
132C.5	315	69,0	2090	400	131	0,130	0,84	90,4	

Note: Speed values must be technically compatible with bearings type and applied accessories

Other windings on request



IP PROTECTION	IP54 (IP55 on request)
THERMAL PROTECTION TYPE	KLIXON (PT100, PTC on request)
BALANCING, VIBRATION GRADE (EN 60034-14 / VDE 0530 part 14)	A (B on request)
INSULATION CLASS	F
COOLING METHOD	16L/1' at 20°C (68°F) + GLYCOL 20%
Amb. Cond.	0 + 40°C (32 + 104°F) 1000m ASL
TRANSDUCER	ENCODER OR RESOLVER (on request)
MOUNTING FORM	B3, B35, or other on request
BRAKE	up to 400 Nm (on request)
DE BEARING	BALL, ROLLER or INSULATED on request
NDE BEARING	ROLLER (insulated on request)
MAX MECHANICAL SPEED	5000 r.p.m. (3500 r.p.m. roller bearing) 8000 r.p.m. (S4 version)
PAINTING SYSTEM	NITRO, POLYURETHANIC, C5M, on request

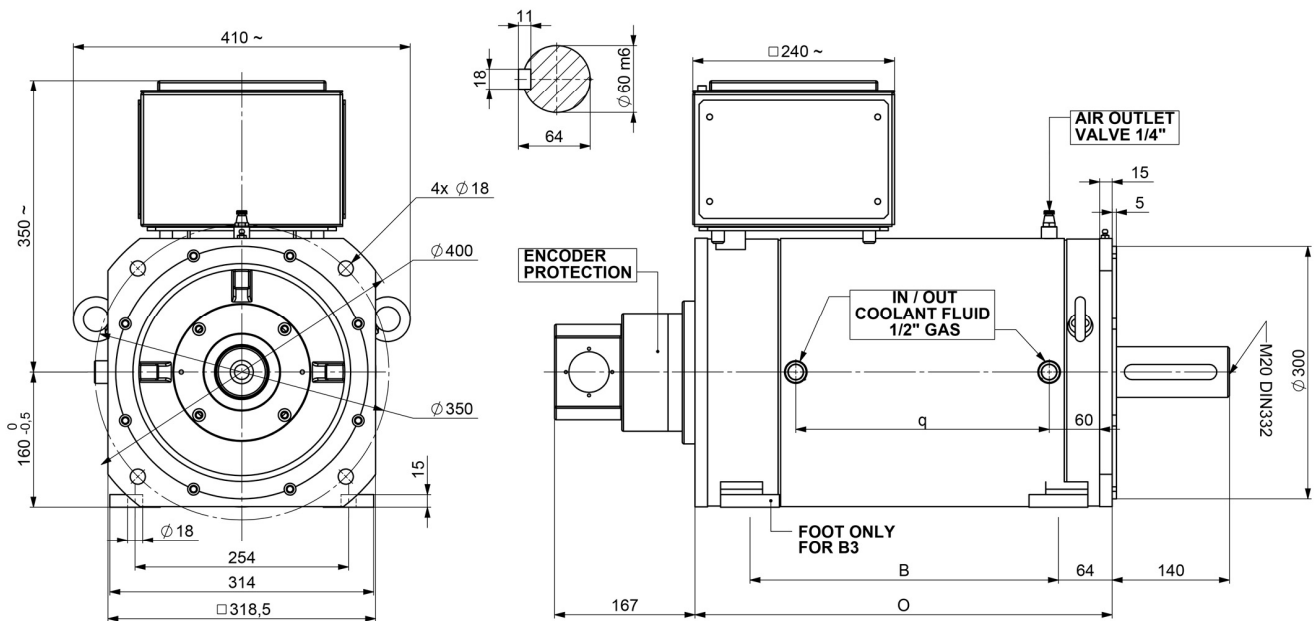

VARIABLES DIMENSIONS BY SIZE			
SIZE	B	O	q
160C.1	367	500	301,5
160C.2	417	550	351,5
160C.3	477	610	411,5
160C.4	537	670	471,5
160C.5	587	720	521,5

unit [mm]

GENERAL DATA

S4 VERSION POWER DERATING: -5%, 160C.5 NOT AVAILABLE IN S4 VERSION

SUPPLY VOLTAGE 400V							Poles: 4		
TYPE	TORQUE Nm	POWER kW	SPEED rpm	VOLTAGE V	CURRENT A	J Kgm ²	COS ϕ	EFF.	
160C.1	315	32	1000	400	58,5	0,21	0,92	0,87	1000 RPM
160C.2	359	38	1010	400	69	0,25	0,90	0,88	
160C.3	430	46	1020	400	83	0,31	0,89	0,90	
160C.4	491	53	1030	400	94,5	0,36	0,89	0,90	
160C.5	539	57	1010	400	102,5	0,40	0,90	0,90	
160C.1	289	44	1520	400	83,5	0,21	0,87	0,89	1500 RPM
160C.2	335	54	1540	400	97	0,25	0,88	0,90	
160C.3	397	64	1540	400	116	0,31	0,89	0,90	
160C.4	452	70	1480	400	126	0,36	0,89	0,91	
160C.5	509	80	1500	400	142,5	0,40	0,90	0,91	
160C.1	284	61	2140	400	106,4	0,21	0,89	0,92	2000 RPM
160C.2	329	75	2180	400	131	0,25	0,89	0,92	
160C.3	389	84	2060	400	147	0,31	0,90	0,92	
160C.4	446	98	2100	400	171	0,36	0,89	0,93	
160C.5	491	107	2080	400	187	0,40	0,90	0,93	

Note: Speed values must be technically compatible with bearings type and applied accessories

Other windings on request

POWERTECH FLUID AX 200C

ASYNCHRONOUS MOTORS

OVERVIEW

Rev. 1.2

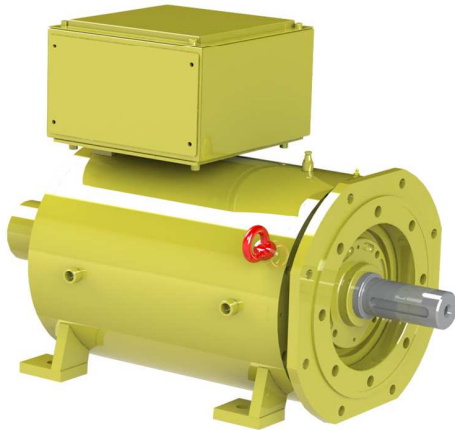

IP PROTECTION	IP54 (IP55 on request)
THERMAL PROTECTION TYPE	KLIXON (PT100, PTC on request)
BALANCING, VIBRATION GRADE (EN 60034-14 / VDE 0530 part 14)	A (B on request)
INSULATION CLASS	F
COOLING METHOD	23L/1' at 20°C (68°F) + GLYCOL 20%
Amb. Cond.	0 + 40°C (32 + 104°F) 1000m ASL
TRANSDUCER	ENCODER OR RESOLVER (on request)
MOUNTING FORM	B3, B35, or other on request
BRAKE	up to 600 Nm (on request)
DE BEARING	BALL, ROLLER or INSULATED on request
NDE BEARING	ROLLER (insulated on request)
MAX MECHANICAL SPEED	4000 r.p.m. (3200 r.p.m. roller bearing) 6500 r.p.m. (S6 version)
PAINTING SYSTEM	NITRO, POLYURETHANIC, C5M, on request

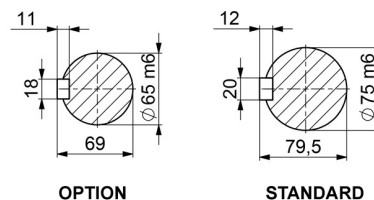
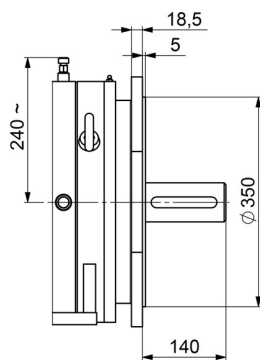
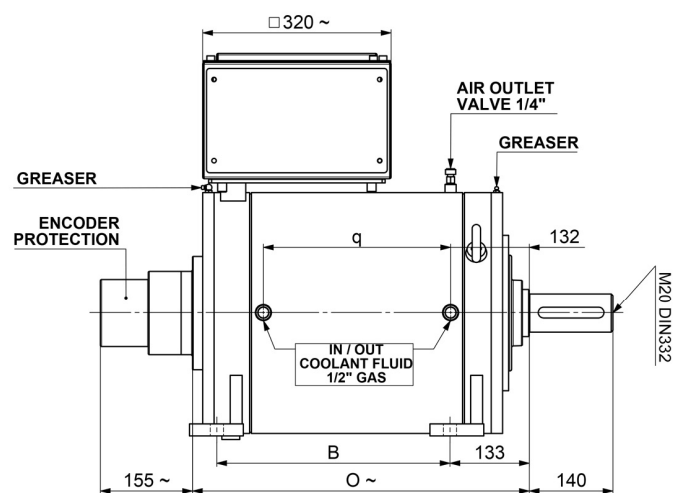
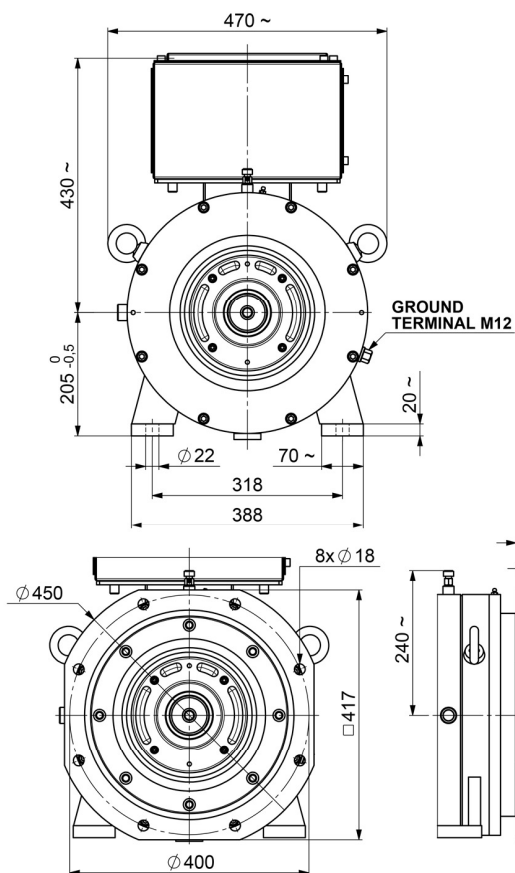

OPTION

STANDARD

VARIABLES DIMENSIONS BY SIZE

SIZE	B	O	q
200C.1	390	565	313
200C.2	430	605	353
200C.3	480	655	403
200C.4	550	725	473
200C.5	650	825	573

unit [mm]

GENERAL DATA

S6 VERSION POWER DERATING: -5%, 200C.5 NOT AVAILABLE IN S6 VERSION

SUPPLY VOLTAGE 400V							Poles: 6		
TYPE	TORQUE Nm	POWER kW	SPEED rpm	VOLTAGE V	CURRENT A	J Kgm ²	COS ϕ	EFF.	
200C.1	571	63	1050	400	116,4	0,55	0,84	0,92	1000 RPM
200C.2	674	72	1020	400	133	0,63	0,84	0,92	
200C.3	794	84	1010	400	155	0,75	0,85	0,93	
200C.4	905	99	1040	400	182	0,90	0,85	0,93	
200C.5	1063	120	1080	400	222	1,14	0,84	0,93	
200C.1	559	92	1570	400	168	0,55	0,84	0,93	1500 RPM
200C.2	646	100	1480	400	183	0,63	0,84	0,93	
200C.3	755	124	1570	400	227	0,75	0,85	0,93	
200C.4	855	141	1570	400	257	0,90	0,85	0,94	
200C.5	1011	161	1520	400	294	1,14	0,85	0,94	
200C.1	486	102	2000	400	183	0,55	0,86	0,94	2000 RPM
200C.2	561	113	1930	400	204	0,63	0,86	0,94	
200C.3	660	131	1900	400	236	0,75	0,86	0,94	
200C.4	760	157	1970	400	282	0,90	0,85	0,94	
200C.5	925	195	2010	400	350	1,14	0,85	0,95	

Note: Speed values must be technically compatible with bearings type and applied accessories

Other windings on request

POWERTECH FLUID AX 250K/KC

ASYNCHRONOUS MOTORS

OVERVIEW

Rev. 1.2

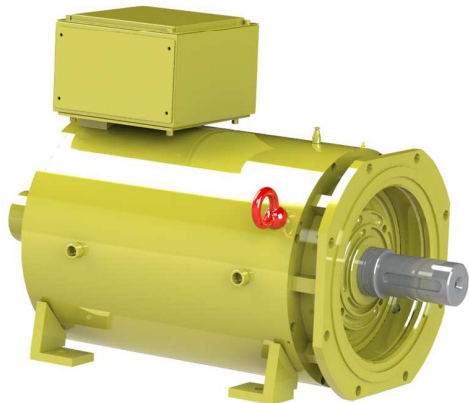

IP PROTECTION	IP54 (IP55 on request)
THERMAL PROTECTION TYPE	KLIXON (PT100, PTC on request)
BALANCING, VIBRATION GRADE (EN 60034-14 / VDE 0530 part 14)	A (B on request)
INSULATION CLASS	F
COOLING METHOD	30L/1' at 20°C (68°F) + GLYCOL 20%
Amb. Cond.	0 + 40°C (32 + 104°F) 1000m ASL
TRANSDUCER	ENCODER OR RESOLVER (on request)
MOUNTING FORM	B3, B35, or other on request
BRAKE	up to 2400 Nm (on request)
DE BEARING	BALL (ROLLER request)
NDE BEARING	ROLLER (insulated on request)
MAX MECHANICAL SPEED	3500 r.p.m. (3000 r.p.m. roller bearing) 6000 r.p.m. (S6 version)
PAINTING SYSTEM	NITRO, POLYURETHANIC, C5M, on request

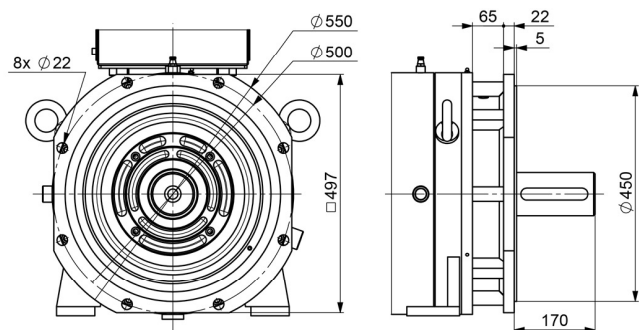
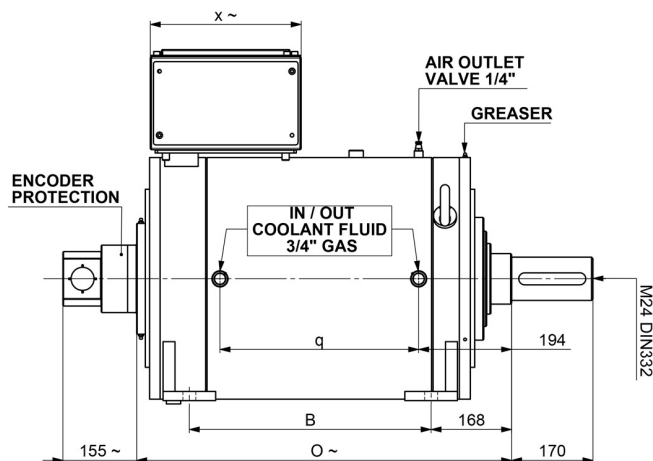
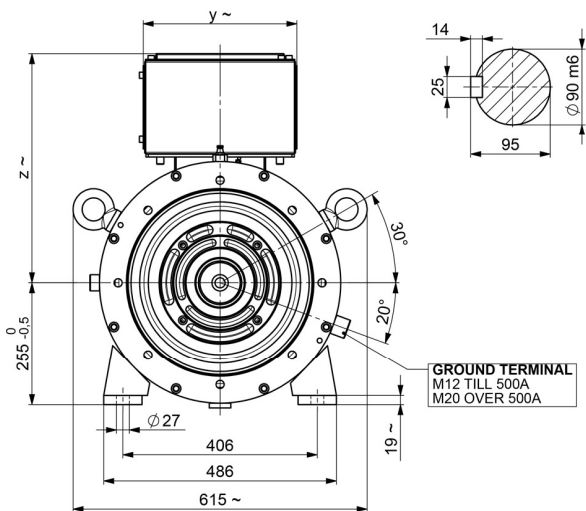

TERMINAL BOX DIMENSIONS			
MOTOR CURRENT	x	y	z
TILL 500 A	315	320	480
OVER 500 A	585	395	535

VARIABLES DIMENSIONS BY SIZE			
SIZE	B	O	q
250K.1	505	785	415
250K.2	575	855	485
250K.3	665	945	575
250K.4	785	1065	695
250K.5	925	1205	835

unit [mm]

GENERAL DATA

All version (S6 VERSION POWER DERATING: -5%, 250K.5 NOT AVAILABLE IN S6 VERSION)

SUPPLY VOLTAGE 400V							Poles: 6		
TYPE	TORQUE Nm	POWER kW	SPEED rpm	VOLTAGE V	CURRENT A	J Kgm ²	COS ϕ	EFF.	
250K.1	1190	130	1040	400	249	2,0	0,84	0,90	RPM 1000
250K.2	1480	173	1120	400	329	2,5	0,84	0,91	
250K.3	1830	201	1050	400	378	3,1	0,84	0,91	
250K.4	2300	257	1070	400	479	3,9	0,84	0,92	
250K.5	2800	296	1010	400	551	4,8	0,84	0,93	
250K.1	1120	193	1650	400	362	2,0	0,83	0,93	RPM 1500
250K.2	1390	218	1500	400	409	2,5	0,83	0,93	
250K.3	1750	291	1600	400	545	3,1	0,83	0,93	
250K.4	2170	345	1520	400	644	3,9	0,83	0,94	
250K.5	2680	432	1540	400	799	4,8	0,84	0,94	
250K.1	1030	207	1920	400	385	2,0	0,84	0,93	RPM 2000
250K.2	1300	277	2050	400	512	2,5	0,84	0,94	
250K.3	1600	331	1980	400	611	3,1	0,84	0,94	
250K.4	2020	415	1960	400	766	3,9	0,84	0,94	
250K.5	2470	551	2130	400	1006	4,8	0,85	0,94	

Cu version (not available in S6 version)

SUPPLY VOLTAGE 400V							Poles: 6		
TYPE	TORQUE Nm	POWER kW	SPEED rpm	VOLTAGE V	CURRENT A	J Kgm ²	COS ϕ	EFF.	
250KC.1	1270	138	1040	400	265	2,0	0,84	0,90	RPM 1000
250KC.2	1570	184	1120	400	350	2,5	0,84	0,91	
250KC.3	1950	214	1050	400	402	3,1	0,84	0,91	
250KC.4	2440	273	1070	400	510	3,9	0,84	0,92	
250KC.5	2980	315	1010	400	586	4,8	0,84	0,93	
250KC.1	1190	205	1650	400	385	2,0	0,83	0,93	RPM 1500
250KC.2	1480	232	1500	400	435	2,5	0,83	0,93	
250KC.3	1860	310	1600	400	580	3,1	0,83	0,93	
250KC.4	2310	367	1520	400	685	3,9	0,83	0,94	
250KC.5	2850	460	1540	400	850	4,8	0,84	0,94	
250KC.1	1100	220	1920	400	410	2,0	0,84	0,93	RPM 2000
250KC.2	1380	295	2050	400	545	2,5	0,84	0,94	
250KC.3	1700	352	1980	400	650	3,1	0,84	0,94	
250KC.4	2150	441	1960	400	815	3,9	0,84	0,94	
250KC.5	2630	586	2130	400	1070	4,8	0,85	0,94	

Note: Speed values must be technically compatible with bearings type and applied accessories

Other windings on request

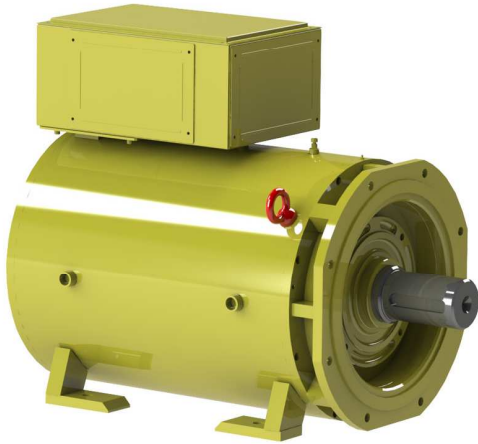

IP PROTECTION	IP54 (IP55 on request)
THERMAL PROTECTION TYPE	KLIXON (PT100, PTC on request)
BALANCING, VIBRATION GRADE (EN 60034-14 / VDE 0530 part 14)	A (B on request)
INSULATION CLASS	F
COOLING METHOD	48L/1' at 20°C (68°F) + GLYCOL 20%
Amb. Cond.	0 + 40°C (32 + 104°F) 1000m ASL
TRANSDUCER	ENCODER OR RESOLVER (on request)
MOUNTING FORM	B3, B35, or other on request
BRAKE	up to 2500 Nm (on request)
DE BEARING	BALL (ROLLER request)
NDE BEARING	ROLLER (INSULATED)
MAX MECHANICAL SPEED	3200 r.p.m. (2400 r.p.m. roller bearing) 4500 r.p.m. (S6 version)
PAINTING SYSTEM	NITRO, POLYURETHANIC, C5M, on request

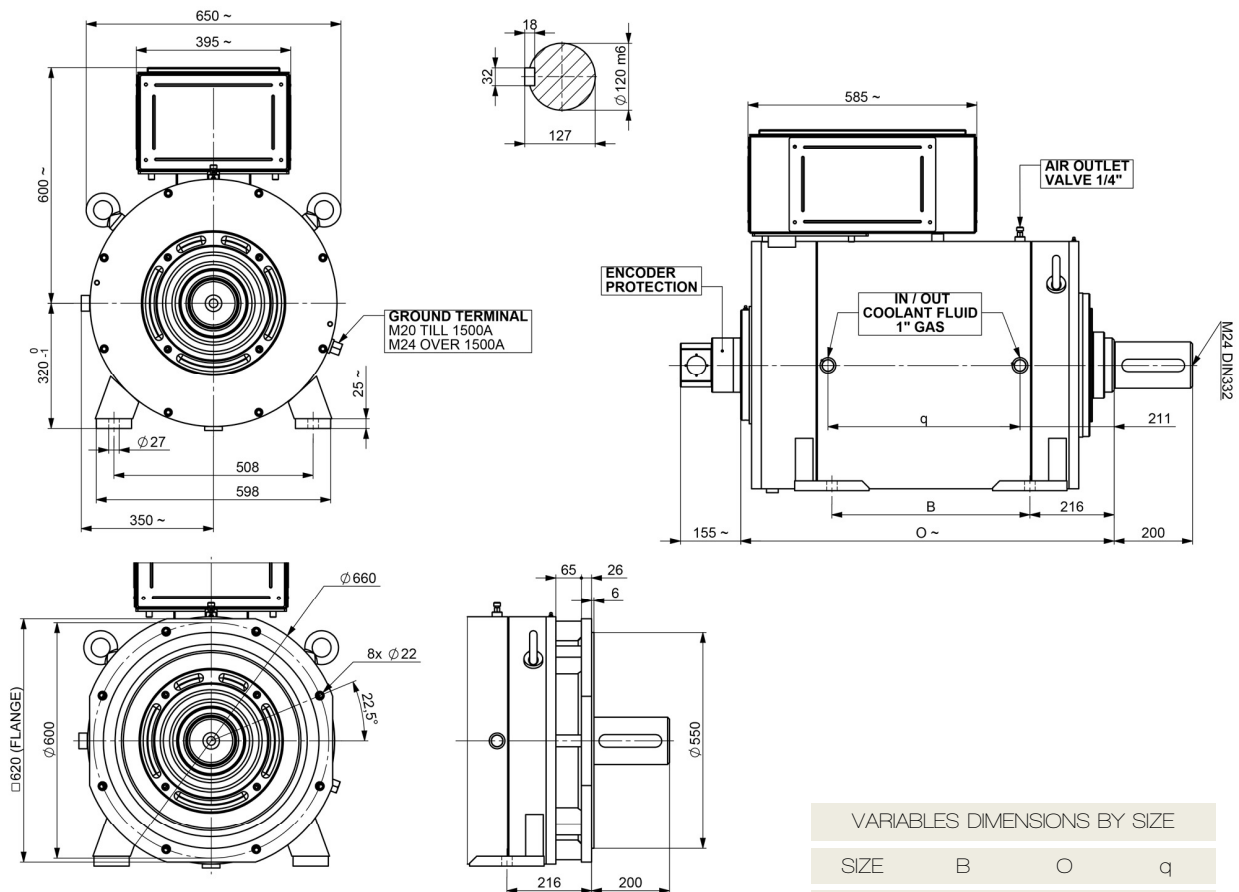

VARIABLES DIMENSIONS BY SIZE

SIZE	B	O	q
315C.1	505	955	490
315C.2	615	1065	600
315C.3	735	1185	720
315C.4	865	1315	850
315C.5	1025	1475	1010

unit [mm]

GENERAL DATA

S6 VERSION POWER DERATING: -12%, 315C.5 NOT AVAILABLE IN S6 VERSION

SUPPLY VOLTAGE 690V							Poles: 6		
TYPE	TORQUE Nm	POWER kW	SPEED rpm	VOLTAGE V	CURRENT A	J Kgm ²	COS ϕ	EFF.	
315C.1	2.300	135	570	690	152	8,0	0,86	0,88	RPM 500
315C.2	3.000	190	610	690	212	10,4	0,86	0,88	
315C.3	3.800	230	580	690	250	12,8	0,87	0,89	
315C.4	4.650	260	530	690	277	15,6	0,87	0,90	
315C.5	5.650	330	560	690	355	18,8	0,87	0,90	
315C.1	2.200	255	1.100	690	267	8,0	0,84	0,95	RPM 1000
315C.2	2.900	325	1.070	690	340	10,4	0,85	0,95	
315C.3	3.700	415	1.080	690	430	12,8	0,86	0,95	
315C.4	4.550	515	1.080	690	525	15,6	0,86	0,96	
315C.5	5.450	650	1.140	690	665	18,8	0,86	0,96	
315C.1	2.150	355	1.580	690	362	8,0	0,86	0,95	RPM 1500
315C.2	2.800	460	1.570	690	470	10,4	0,86	0,95	
315C.3	3.550	570	1.550	690	580	12,8	0,87	0,95	
315C.4	4.300	760	1.690	690	760	15,6	0,87	0,96	
315C.5	5.200	860	1.590	690	865	18,8	0,87	0,96	
315C.1	1.900	395	2.010	690	410	8,0	0,85	0,95	RPM 2000
315C.2	2.450	535	2.100	690	555	10,4	0,85	0,95	
315C.3	3.050	670	2.100	690	685	12,8	0,86	0,95	
315C.4	3.750	825	2.100	690	835	15,6	0,86	0,96	
315C.5	4.550	915	1.930	690	930	18,8	0,86	0,96	

Note: Speed values must be technically compatible with bearings type and applied accessories

GENERAL DATA

S6 VERSION POWER DERATING: -12%, 315C.5 NOT AVAILABLE IN S6 VERSION

SUPPLY VOLTAGE 460V							Poles: 6		
TYPE	TORQUE Nm	POWER kW	SPEED rpm	VOLTAGE V	CURRENT A	J Kgm ²	COS ϕ	EFF.	
315C.1	2.300	142	590	460	235	8,0	0,86	0,88	500 RPM
315C.2	3.000	190	610	460	318	10,4	0,86	0,88	
315C.3	3.800	220	560	460	360	12,8	0,87	0,89	
315C.4	4.650	280	580	460	452	15,6	0,87	0,90	
315C.5	5.650	345	580	460	550	18,8	0,87	0,90	
315C.1	2.200	255	1.100	460	400	8,0	0,84	0,95	1000 RPM
315C.2	2.900	337	1.110	460	527	10,4	0,85	0,95	
315C.3	3.700	435	1.130	460	676	12,8	0,86	0,95	
315C.4	4.550	515	1.080	460	788	15,6	0,86	0,96	
315C.5	5.450	585	1.020	460	890	18,8	0,86	0,96	
315C.1	2.150	340	1.520	460	525	8,0	0,86	0,95	1500 RPM
315C.2	2.800	440	1.490	460	674	10,4	0,86	0,95	
315C.3	3.550	585	1.580	460	892	12,8	0,87	0,95	
315C.4	4.300	750	1.660	460	1.125	15,6	0,87	0,96	
315C.5	5.200	865	1.590	460	1.300	18,8	0,87	0,96	

Note: Speed values must be technically compatible with bearings type and applied accessories

GENERAL DATA

S6 VERSION POWER DERATING: -12%, 315C.5 NOT AVAILABLE IN S6 VERSION

SUPPLY VOLTAGE 400V							Poles: 6		
TYPE	TORQUE Nm	POWER kW	SPEED rpm	VOLTAGE V	CURRENT A	J Kgm ²	COS ϕ	EFF.	
315C.1	2.300	135	560	400	258	8,0	0,86	0,88	500 RPM
315C.2	3.000	190	610	400	365	10,4	0,86	0,88	
315C.3	3.800	225	560	400	416	12,8	0,87	0,89	
315C.4	4.650	270	550	400	497	15,6	0,87	0,90	
315C.5	5.650	335	570	400	620	18,8	0,87	0,90	
315C.1	2.200	265	1.150	400	480	8,0	0,84	0,95	1000 RPM
315C.2	2.900	330	1.090	400	590	10,4	0,85	0,95	
315C.3	3.700	420	1.080	400	745	12,8	0,86	0,95	
315C.4	4.550	515	1.080	400	910	15,6	0,86	0,96	
315C.5	5.450	570	1.000	400	1.000	18,8	0,86	0,96	
315C.1	2.150	355	1.580	400	628	8,0	0,86	0,95	1500 RPM
315C.2	2.800	460	1.570	400	815	10,4	0,86	0,95	
315C.3	3.550	575	1.550	400	1.000	12,8	0,87	0,95	
315C.4	4.300	760	1.690	400	1.315	15,6	0,87	0,96	
315C.5	5.200	750	1.380	400	1.300	18,8	0,87	0,96	
315C.1	1.900	420	2.130	400	755	8,0	0,85	0,95	2000 RPM
315C.2	2.450	535	2.100	400	960	10,4	0,85	0,95	
315C.3	2.950	695	2.250	400	1.230	12,8	0,86	0,95	
315C.4	NOT AVAILABLE								
315C.5	NOT AVAILABLE								

Note: Speed values must be technically compatible with bearings type and applied accessories

Other windings on request

HIGH SPEED ASYNCHRONOUS MOTORS

RELIABILITY
HIGH EFFICIENCY
HIGH TORQUE/INERTIA RATIO
HIGH SPEED RANGE AND DYNAMIC
LOW INERTIA (4 poles)
VERY LOW INERTIA (2 poles)
SUITABLE FOR VECTOR DRIVES
IGBT COMPLIANT
WIDE RANGE OF CUSTOMIZATION AND
OPTIONS

TYPICAL APPLICATIONS

RIG TEST FOR MOTORS AND TRANSMISSIONS
HYDRAULIC PUMPS MOVEMENT
TEXTILE MACHINERY
COMPRESSORS
CENTRIFUGES

IP PROTECTION

IP21

COOLING METHOD

IC 06



HIGH SPEED MOTORS FOR HIGH SPEED APPLICATIONS



IP PROTECTION	IP21
THERMAL PROTECTION TYPE	KLIXON (PT100, PTC on request)
BALANCING, VIBRATION GRADE (EN 60034-14 / VDE 0530 part 14)	A (B on request)
INSULATION CLASS	F
COOLING METHOD	IC06 (with filter on request)
Amb. Cond.	0 + 40°C (32 + 104°F) 1000m ASL
TRANSDUCER	ENCODER OR RESOLVER (on request)
MOUNTING FORM	B3, B35, or other on request
AVAILABLE SIZES	200L, 225, 250K, 280, 315L, 355
DE BEARING	BALL (WITH PT100 PROBE)
NDE BEARING	BALL (WITH PT100 PROBE)
MAX MECHANICAL SPEED	Up to 10000 rpm
PAINING SYSTEM	NITRO, POLYURETHANIC, C5M, on request

**Drawings available only on demand,
according with Customer specifics**

S4 TETRAVEC 200L

poles 2p=4			U _N = 400V											
T _{max} /T _n = 2,0			S1						S6/40%				J kgm ²	Max mech. speed RPM
TYPE	HZ	RPM	I _n A	P _n kW	T _n Nm	cosφ	const. power max RPM	Eff.	I A	P kW	T Nm	const. power max RPM		
200L.1	63,8	1.900	150	82	415	0,85	3.450	0,92	210	115	580	2.500	0,54	7.500
200L.2	63,8	1.900	175	94	475	0,85	3.650	0,92	245	135	680	2.600	0,62	
200L.3	64,1	1.910	205	112	565	0,85	3.800	0,92	290	160	805	2.700	0,72	
200L.35	62,8	1.870	225	123	635	0,85	3.850	0,93	315	175	895	2.750	0,76	
T _{max} /T _n = 2,0			S1						S6/40%				J kgm ²	Max mech. speed RPM
TYPE	HZ	RPM	I _n A	P _n kW	T _n Nm	cosφ	const. power max RPM	Eff.	I A	P kW	T Nm	const. power max RPM		
200L.1	83,8	2.500	180	100	385	0,86	4.500	0,92	255	140	535	3.250	0,54	7.500
200L.2	87,2	2.600	215	118	435	0,86	4.950	0,92	305	170	625	3.550	0,62	
200L.3	85,5	2.550	245	135	510	0,86	5.050	0,93	345	190	715	3.600	0,72	
200L.35	88,2	2.630	285	157	575	0,86	5.400	0,93	400	225	820	3.900	0,76	

S2 TETRAVEC 200L

poles 2p=2			U _N = 400V											
T _{max} /T _n = 2,0			S1						S6/40%				J kgm ²	Max mech. speed RPM
TYPE	HZ	RPM	I _n A	P _n kW	T _n Nm	cosφ	const. power max RPM	Eff.	I A	P kW	T Nm	const. power max RPM		
200L.1	55,4	3.300	170	100	290	0,92	5.650	0,92	240	140	410	4.050	0,31	7.500
200L.2	54,6	3.250	195	115	340	0,92	5.850	0,92	275	165	485	4.200	0,36	
200L.3	53,7	3.200	230	135	405	0,92	6.100	0,93	325	190	570	4.350	0,42	
200L.35	50,4	3.000	245	145	465	0,93	6.000	0,93	345	205	655	4.300	0,45	
T _{max} /T _n = 2,0			S1						S6/40%				J kgm ²	Max mech. speed RPM
TYPE	HZ	RPM	I _n A	P _n kW	T _n Nm	cosφ	const. power max RPM	Eff.	I A	P kW	T Nm	const. power max RPM		
200L.1	77,1	4.600	210	125	260	0,92	7.400	0,94	295	175	365	5.200	0,31	7.500
200L.2	72,9	4.350	225	135	300	0,92	7.400	0,94	315	190	420	5.350	0,36	
200L.3	72,1	4.300	265	160	360	0,92	7.400	0,94	375	225	500	5.300	0,42	
200L.35	69,6	4.150	295	180	420	0,93	7.500	0,95	415	255	590	5.400	0,45	

Note: Speed values must be technically compatible with bearings type and applied accessories

S4 TETRAVEC 250K

poles 2p=4			$U_N = 400V$											
$T_{max}/T_n = 1,85$			S1						S6/40%				J kgm ²	Max mech. speed RPM
TYPE	HZ	RPM	I_n A	P_n kW	T_n Nm	$\cos\phi$	const. power max RPM	Eff.	I A	P kW	T Nm	const. power max RPM		
250K.1	61,4	1.830	275	147	770	0,84	3.150	0,92	385	210	1.100	2.250	1,3	6.500
250K.2	62,4	1.860	350	188	970	0,85	3.350	0,93	490	265	1.365	2.400	1,6	
250K.3	62,7	1.870	430	235	1.205	0,85	3.600	0,93	605	330	1.690	2.550	2,0	
250K.35	60,4	1.800	475	260	1.380	0,85	3.600	0,93	665	365	1.940	2.600	2,2	
$T_{max}/T_n = 1,75$			S1						S6/40%				J kgm ²	Max mech. speed RPM
TYPE	HZ	RPM	I_n A	P_n kW	T_n Nm	$\cos\phi$	const. power max RPM	Eff.	I A	P kW	T Nm	const. power max RPM		
250K.1	83,7	2.500	325	180	690	0,86	4.000	0,94	455	255	975	2.850	1,3	6.500
250K.2	83,1	2.480	405	226	875	0,86	4.000	0,94	570	320	1.235	2.850	1,6	
250K.3	80,7	2.410	485	273	1.085	0,87	4.100	0,94	680	385	1.530	2.950	2,0	
250K.35	81,1	2.420	560	315	1.245	0,87	4.400	0,94	785	445	1.760	3.150	2,2	

S2 TETRAVEC 250K

poles 2p=2			$U_N = 400V$											
$T_{max}/T_n = 1,8$			S1						S6/40%				J kgm ²	Max mech. speed RPM
TYPE	HZ	RPM	I_n A	P_n kW	T_n Nm	$\cos\phi$	const. power max RPM	Eff.	I A	P kW	T Nm	const. power max RPM		
250K.1	55,3	3.300	310	184	535	0,93	5.650	0,93	435	260	755	4.050	1,0	6.500
250K.2	51,9	3.100	350	212	655	0,93	5.600	0,94	490	300	925	4.000	1,2	
250K.3	50,2	3.000	425	258	825	0,93	5.700	0,94	595	365	1.165	4.050	1,5	
250K.35	53,5	3.200	525	320	960	0,93	6.400	0,94	735	450	1.345	4.550	1,6	
$T_{max}/T_n = 1,7$			S1						S6/40%				J kgm ²	Max mech. speed RPM
TYPE	HZ	RPM	I_n A	P_n kW	T_n Nm	$\cos\phi$	const. power max RPM	Eff.	I A	P kW	T Nm	const. power max RPM		
250K.1	71,9	4.300	335	204	455	0,94	6.500	0,94	470	290	645	4.900	1,0	6.500
250K.2	69,4	4.150	405	245	565	0,94	6.500	0,94	570	345	795	5.100	1,2	
250K.3	68,6	4.100	490	300	700	0,94	6.500	0,94	690	420	980	5.050	1,5	
250K.35	68,6	4.100	570	350	820	0,94	6.500	0,95	800	495	1.155	5.350	1,6	

Note: Speed values must be technically compatible with bearings type and applied accessories

S4 TETRAVEC 315L

poles 2p=4			$U_N = 400V$											
$T_{max}/T_n = 2,0$			S1						S6/40%				J kgm ²	Max mech. speed RPM
TYPE	HZ	RPM	I_n A	P_n kW	T_n Nm	$\cos\phi$	const. power max RPM	Eff.	I A	P kW	T Nm	const. power max RPM		
315L.1	61,0	1.820	555	320	1.680	0,88	3.350	0,94	780	450	2.365	2.400	4,5	5.000
315L.2	57,7	1.720	685	397	2.205	0,89	3.150	0,94	960	560	3.110	2.300	5,9	
315L.3	61,4	1.830	920	536	2.800	0,89	3.500	0,94	1.290	755	3.945	2.500	7,4	
$T_{max}/T_n = 2,0$			S1						S6/40%				J kgm ²	Max mech. speed RPM
TYPE	HZ	RPM	I_n A	P_n kW	T_n Nm	$\cos\phi$	const. power max RPM	Eff.	I A	P kW	T Nm	const. power max RPM		
315L.1	80,4	2.400	655	377	1.500	0,89	4.400	0,94	920	530	2.110	3.150	4,5	5.000
315L.2	81,4	2.430	865	504	1.980	0,89	4.450	0,94	1.215	710	2.795	3.200	5,9	
315L.3	77,4	2.310	1.045	610	2.520	0,89	4.400	0,95	1.465	855	3.535	3.150	7,4	

S2 TETRAVEC 315L

poles 2p=2			$U_N = 400V$											
$T_{max}/T_n = 1,8$			S1						S6/40%				J kgm ²	Max mech. speed RPM
TYPE	HZ	RPM	I_n A	P_n kW	T_n Nm	$\cos\phi$	const. power max RPM	Eff.	I A	P kW	T Nm	const. power max RPM		
315L.1	53,6	3.200	625	375	1.120	0,93	5.000	0,94	840	505	1.510	3.650	2,4	5.000
315L.2	50,3	3.000	795	480	1.530	0,93	5.000	0,94	1.115	675	2.150	3.700	3,1	
315L.3	40,2	2.400	785	485	1.930	0,95	4.400	0,94	1.110	680	2.710	3.200	3,9	
$T_{max}/T_n = 1,65$			S1						S6/40%				J kgm ²	Max mech. speed RPM
TYPE	HZ	RPM	I_n A	P_n kW	T_n Nm	$\cos\phi$	const. power max RPM	Eff.	I A	P kW	T Nm	const. power max RPM		
315L.1	73,6	4.400	700	424	925	0,93	5.000	0,94	980	595	1.295	4.900	2,4	5.000
315L.2	74,4	4.450	940	570	1.225	0,94	5.000	0,94	1.320	800	1.720	5.000	3,1	
315L.3	56,8	3.400	935	575	1.615	0,93	5.000	0,95	1.330	805	2.260	4.800	3,9	

Note: Speed values must be technically compatible with bearings type and applied accessories

HS2 TETRAVEC 225

poles 2p=2			U _N = 400V											
T _{max} /T _n = 2,0			S1						S6/40%				J kgm ²	Max mech. speed RPM
TYPE	HZ	RPM	I _n A	P _n kW	T _n Nm	cos φ	const. power max RPM	Eff.	I A	P kW	T Nm	const. power max RPM		
225.1	77,1	4.600	210	125	260	0,92	7.400	0,94	295	175	365	5.200	0,31	10.000
225.2	72,9	4.350	225	135	300	0,92	7.400	0,94	315	190	420	5.350	0,36	
225.3	72,1	4.300	265	160	360	0,92	7.400	0,94	375	225	500	5.300	0,42	
225.35	69,6	4.150	295	180	420	0,93	7.600	0,95	415	255	590	5.400	0,45	

HS2 TETRAVEC 280

poles 2p=2			U _N = 400V											
T _{max} /T _n = 1,7			S1						S6/40%				J kgm ²	Max mech. speed RPM
TYPE	HZ	RPM	I _n A	P _n kW	T _n Nm	cos φ	const. power max RPM	Eff.	I A	P kW	T Nm	const. power max RPM		
280.1	71,9	4.300	335	204	455	0,94	6.900	0,94	470	290	645	4.900	1,0	10.000
280.2	69,4	4.150	405	245	565	0,94	7.100	0,94	570	345	795	5.100	1,2	
280.3	68,6	4.100	490	300	700	0,94	7.100	0,94	690	420	980	5.050	1,5	
280.35	68,6	4.100	570	350	820	0,94	7.500	0,95	800	495	1.155	5.350	1,6	

HS2 TETRAVEC 355

poles 2p=2			U _N = 400V											
T _{max} /T _n = 1,65			S1						S6/40%				J kgm ²	Max mech. speed RPM
TYPE	HZ	RPM	I _n A	P _n kW	T _n Nm	cos φ	const. power max RPM	Eff.	I A	P kW	T Nm	const. power max RPM		
355.1	73,6	4.400	700	424	925	0,93	6.850	0,94	980	595	1.295	4.900	2,4	8.500
355.2	74,4	4.450	940	570	1.225	0,94	7.350	0,94	1.320	800	1.720	5.500	3,1	
315L.3	56,8	3.400	935	575	1.615	0,93	6.500	0,95	1.330	805	2.260	4.800	3,9	

SYNCHRONOUS PERMANENT MAGNETS TORQUE MOTORS

RELIABILITY
 VERY HIGH TORQUE
 EXCELLENT TORQUE/WEIGHT RATIO
 VERY HIGH EFFICIENCY AT LOW SPEED
 HIGH POLARITY (up to 44 poles) FOR EASY
 CONTROL AT LOW SPEED
 SUITABLE FOR VECTOR DRIVES
 IGBT COMPLIANT
 WIDE RANGE OF CUSTOMIZATION AND
 OPTIONS

TYPICAL APPLICATIONS

PRESSES
 ENERGY RECOVERY SYSTEMS
 FOOD BOXES EXTRUDERS
 PAPER AND CARDBOARD PRODUCTION
 MACHINERY
 PROCESSING AND CUTTING METAL PLATES
 METAL WIRE PROCESSING MACHINERY
 PLASTIC AND RUBBER EXTRUDERS
 LIFTING AND HANDLING SYSTEMS
 PACKAGING MACHINERY
 PRINTING MACHINERY
 TRACTION CONTROL
 MACHINE TOOLS
 COMPRESSORS

IP PROTECTION **IP54** or **IP55**
 COOLING METHOD **LIQUID**

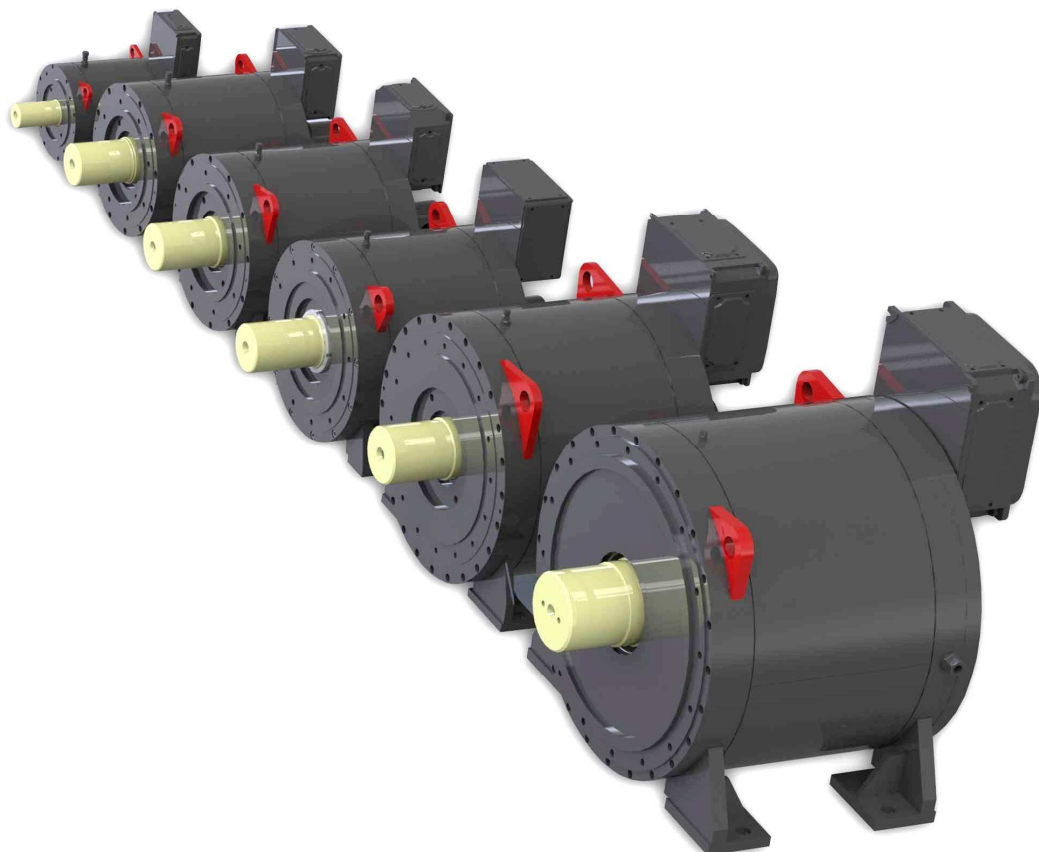

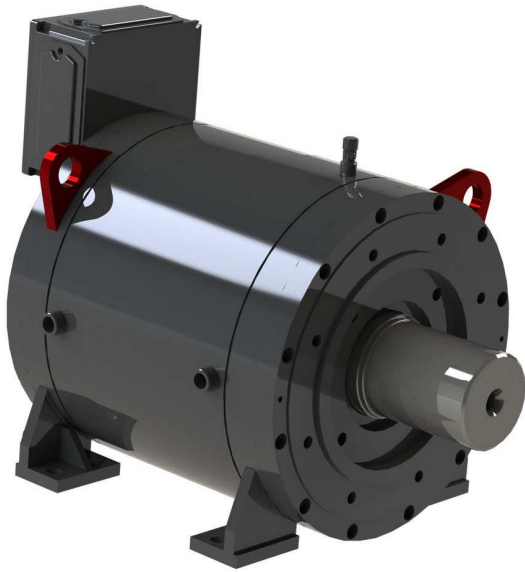

IP PROTECTION	IP54 (IP55 on request)
THERMAL PROTECTION TYPE	PT100 (and other on request)
COOLING METHOD	LIQUID (flow rate by size) 10 + 25°C (50 + 77 °F) + GLYCOL 20%
INSULATION CLASS	F
Amb. Cond.	0 + 40°C (32 + 104°F) 1000m ASL
TRANSDUCER	ENCODER OR RESOLVER (on request)
MOUNTING FORM	B3, B35, or other on request
AVAILABLE SIZES	13, 16, 20, 25, 31, 40
PAINTING SYSTEM	NITRO, POLYURETHANIC, C5M, on request

**Drawings available only on demand,
 according with Customer specifics**

ST22 FLUID 13

400V SUPPLY STANDARD WINDING CODES

Type	poles	Max. torque at 400V	Rated torque	Rated voltage	Rated speed	Rated power	Rated current	Efficiency	Max. suggested speed at const. Power 400V	Magnet ring Inertia	Liquid flow rate
		Nm	Nm	V	rpm	kW	A	η	rpm	Kgm ²	L/1'
13.16	22	525	292	365	200	6,1	15	0,77	490	0,05	8
13.20	22	660	365	365	200	7,6	19	0,78	500	0,07	9
13.24	22	790	440	365	200	9,2	22	0,78	500	0,08	10
13.32	22	1.025	585	375	200	12,3	26	0,79	490	0,11	12
13.40	22	1.295	730	370	200	15,3	36	0,79	500	0,14	14
13.16	22	495	288	365	300	9,0	21	0,83	700	0,05	8
13.20	22	615	360	365	300	11,3	26	0,83	700	0,07	9
13.24	22	730	432	370	300	13,6	31	0,83	700	0,08	10
13.32	22	960	575	375	300	18,0	40	0,84	680	0,11	12
13.40	22	1.200	720	375	300	22,6	50	0,84	680	0,14	14
13.16	22	480	286	365	400	12,0	26	0,86	700	0,05	8
13.20	22	600	358	365	400	15,0	33	0,86	700	0,07	9
13.24	22	700	430	375	400	18,0	40	0,86	700	0,08	10
13.32	22	960	572	365	400	24,0	53	0,87	700	0,11	12
13.40	22	1.200	715	365	400	30,0	66	0,87	700	0,14	14

All data outputs are referred to power converter clocking frequency (PWM) >4kHz

Other windings and sizes on request

POWER DERATING BY INLET LIQUID TEMPERATURE

30°C (86°F) -3,5%

35°C (95°F) -6%

40°C (104°F) -10%

45°C (113°F) -12%

NOT COOLED VERSION IC410 on demand (POWER DERATING -55%)

ST22 FLUID 16

400V SUPPLY STANDARD WINDING CODES

Type	poles	Max. torque at 400V	Rated torque	Rated voltage	Rated speed	Rated power	Rated current	Efficiency	Max. suggested speed at const. Power 400V	Magnet ring Inertia	Liquid flow rate
		Nm	Nm	V	rpm	kW	A	η	rpm	Kgm ²	L/1'
16.16	22	1.020	615	380	200	13,1	29	0,84	450	0,16	12
16.20	22	1.290	770	375	200	16,1	36	0,84	480	0,20	13
16.24	22	1.510	925	385	200	19,4	42	0,85	450	0,24	14
16.32	22	2.010	1.230	385	200	25,8	55	0,85	460	0,32	16
16.40	22	2.515	1.530	385	200	32,0	67	0,89	460	0,40	18
16.16	22	990	600	380	300	18,8	39	0,89	650	0,16	12
16.20	22	1.255	750	375	300	23,6	49	0,89	670	0,20	13
16.24	22	1.505	910	375	300	28,6	59	0,89	680	0,24	14
16.32	22	2.005	1.200	375	300	37,7	78	0,90	680	0,32	16
16.40	22	2.505	1.500	375	300	47,1	97	0,90	680	0,40	18
16.16	22	1.005	595	365	400	24,9	52	0,91	700	0,16	12
16.20	22	1.240	740	370	400	31,0	64	0,91	700	0,20	13
16.24	22	1.485	890	370	400	37,3	77	0,91	700	0,24	14
16.32	22	1.855	1.190	395	400	49,8	95	0,92	700	0,32	16
16.40	22	2.510	1.485	365	400	62,2	127	0,92	700	0,40	18

All data outputs are referred to power converter clocking frequency (PWM) >4kHz

Other windings and sizes on request

POWER DERATING BY INLET LIQUID TEMPERATURE

30°C (86°F) -3,5%

35°C (95°F) -6%

40°C (104°F) -10%

45°C (113°F) -12%

NOT COOLED VERSION IC410 on demand (POWER DERATING -55%)

ST30 FLUID 20

400V SUPPLY STANDARD WINDING CODES

Type	poles	Max. torque at 400V	Rated torque	Rated voltage	Rated speed	Rated power	Rated current	Efficiency	Max. suggested speed at const. Power 400V	Magnet ring Inertia	Liquid flow rate
		Nm	Nm	V	rpm	kW	A	η	rpm	Kgm ²	L/1'
20.18	30	2.380	1.240	370	100	13,0	30	0,81	250	0,48	18
20.23	30	2.900	1.550	380	100	16,2	36	0,81	230	0,59	19
20.27	30	3.520	1.860	375	100	19,4	43	0,81	240	0,71	20
20.36	30	4.760	2.480	370	100	26,0	57	0,82	250	0,95	22
20.45	30	6.030	3.100	365	100	32,5	75	0,82	260	1,18	24
20.18	30	2.180	1.220	370	200	25,6	53	0,89	480	0,48	18
20.23	30	2.690	1.525	375	200	32,0	66	0,89	480	0,59	19
20.27	30	3.220	1.830	375	200	38,3	79	0,89	480	0,71	20
20.36	30	4.350	2.440	370	200	51,1	106	0,89	500	0,95	22
20.45	30	5.440	3.050	370	200	64,0	133	0,89	500	1,18	24
20.18	30	2.100	1.200	370	300	37,7	77	0,91	500	0,48	18
20.23	30	2.590	1.500	375	300	47,0	95	0,91	500	0,59	19
20.27	30	3.190	1.800	365	300	56,8	117	0,92	500	0,71	20
20.36	30	4.140	2.400	375	300	75,4	150	0,92	500	0,95	22
20.45	30	5.320	3.000	365	300	94,0	190	0,92	500	1,18	24

All data outputs are referred to power converter clocking frequency (PWM) >4kHz

Other windings and sizes on request

POWER DERATING BY INLET LIQUID TEMPERATURE

30°C (86°F) -3,5%

35°C (95°F) -6%

40°C (104°F) -10%

45°C (113°F) -12%

NOT COOLED VERSION IC410 on demand (POWER DERATING -55%)

ST30 FLUID 25

400V SUPPLY STANDARD WINDING CODES

Type	poles	Max. torque at 400V	Rated torque	Rated voltage	Rated speed	Rated power	Rated current	Efficiency	Max. suggested speed at const. Power 400V	Magnet ring Inertia	Liquid flow rate
		Nm	Nm	V	rpm	kW	A	η	rpm	Kgm ²	L/1'
25.20	30	3.760	2.060	365	100	21,6	48	0,85	250	1,16	20
25.25	30	4.710	2.575	365	100	27,0	59	0,85	250	1,45	22
25.30	30	5.420	3.090	380	100	32,4	68	0,87	230	1,74	24
25.40	30	7.430	4.120	370	100	43,1	92	0,87	250	2,32	28
25.50	30	9.410	5.150	365	100	54,0	116	0,87	260	2,90	32
25.20	30	3.540	2.050	370	150	32,2	67	0,90	330	1,16	20
25.25	30	4.260	2.550	385	150	40,0	80	0,90	300	1,45	22
25.30	30	5.240	3.060	375	150	48,1	98	0,90	330	1,74	24
25.40	30	6.900	4.080	380	150	64,1	127	0,90	320	2,32	28
25.50	30	8.630	5.100	380	150	80,1	159	0,90	330	2,90	32
25.20	30	3.450	2.000	370	250	52,4	105	0,93	450	1,16	20
25.25	30	4.140	2.500	385	250	65,4	125	0,93	450	1,45	22
25.30	30	5.170	3.000	370	250	78,5	156	0,93	450	1,74	24
25.40	30	6.890	4.000	370	250	105	208	0,93	450	2,32	28
25.50	30	8.280	5.000	385	250	131	250	0,93	450	2,90	32

All data outputs are referred to power converter clocking frequency (PWM) >4kHz

Other windings and sizes on request

POWER DERATING BY INLET LIQUID TEMPERATURE

30°C (86°F) -3,5%

35°C (95°F) -6%

40°C (104°F) -10%

45°C (113°F) -12%

NOT COOLED VERSION IC410 on demand (POWER DERATING -55%)

ST44 FLUID 31

400V SUPPLY STANDARD WINDING CODES

Type	poles	Max. torque at 400V	Rated torque	Rated voltage	Rated speed	Rated power	Rated current	Efficiency	Max. suggested speed at const. Power 400V	Magnet ring Inertia	Liquid flow rate
		Nm	Nm	V	rpm	kW	A	η	rpm	Kgm ²	L/1'
31.29	44	9.410	4.740	370	100	49,6	101	0,90	240	5,43	32
31.34	44	10.830	5.560	375	100	58,2	119	0,90	230	6,34	34
31.38	44	12.380	6.380	375	100	66,8	133	0,91	240	7,24	36
31.43	44	14.120	7.200	370	100	75,4	154	0,91	250	8,15	38
31.48	44	15.070	8.030	385	100	84,1	166	0,91	230	9,05	40
31.53	44	17.730	8.850	360	100	92,8	196	0,91	270	9,96	42
31.29	44	9.230	4.680	365	150	73,5	150	0,93	340	5,43	32
31.34	44	10.340	5.500	380	150	86,4	169	0,93	310	6,34	34
31.38	44	12.310	6.310	365	150	99,1	201	0,93	350	7,24	36
31.43	44	13.660	7.120	370	150	112	225	0,93	340	8,15	38
31.48	44	15.170	7.940	370	150	125	251	0,93	350	9,05	40
31.53	44	16.250	8.750	380	150	137	266	0,93	330	9,96	42
31.29	44	9.210	4.600	360	250	120	243	0,94	400	5,43	32
31.34	44	10.310	5.450	375	250	143	280	0,94	400	6,34	34
31.38	44	11.940	6.250	370	250	164	324	0,94	400	7,24	36
31.43	44	13.080	7.050	380	250	185	352	0,94	400	8,15	38
31.48	44	14.350	7.800	385	250	204	382	0,94	400	9,05	40
31.53	44	15.780	8.600	385	250	225	423	0,94	400	9,96	42

All data outputs are referred to power converter clocking frequency (PWM) >4kHz

Other windings and sizes on request

POWER DERATING BY INLET LIQUID TEMPERATURE

30°C (86°F) -3,5%

35°C (95°F) -6%

40°C (104°F) -10%

45°C (113°F) -12%

NOT COOLED VERSION IC410 on demand (POWER DERATING -55%)

ST44 FLUID 40

400V SUPPLY STANDARD WINDING CODES

Type	poles	Max. torque at 400V	Rated torque	Rated voltage	Rated speed	Rated power	Rated current	Efficiency	Max. suggested speed at const. Power 400V	Magnet ring Inertia	Liquid flow rate
		Nm	Nm	V	rpm	kW	A	η	rpm	Kgm ²	L/1'
40.35	44	18.800	11.900	370	80	100	205	0,90	190	15,79	41
40.40	44	21.500	13.600	370	80	114	234	0,90	190	18,05	44
40.45	44	23.900	15.300	375	80	128	260	0,91	190	20,30	47
40.50	44	26.900	17.000	370	80	143	293	0,91	200	22,56	50
40.55	44	29.600	18.700	370	80	157	320	0,91	210	24,83	53
40.60	44	31.400	20.400	380	80	171	337	0,91	200	27,07	56
40.35	44	17.900	11.800	380	140	173	335	0,93	340	15,79	41
40.40	44	21.000	13.450	370	140	197	392	0,94	350	18,05	44
40.45	44	24.000	15.150	365	140	222	446	0,94	350	20,30	47
40.50	44	25.600	16.850	380	140	247	480	0,94	350	22,56	50
40.55	44	27.400	18.500	390	140	271	510	0,94	340	24,83	53
40.60	44	29.900	20.200	390	140	296	556	0,94	340	27,07	56
40.35	44	18.100	11.650	375	200	244	475	0,94	350	15,79	41
40.40	44	21.250	13.300	365	200	279	554	0,94	350	18,05	44
40.45	44	23.250	15.050	375	200	315	610	0,95	350	20,30	47
40.50	44	25.500	16.700	380	200	350	665	0,95	350	22,56	50
40.55	44	28.050	18.350	380	200	384	735	0,95	350	24,83	53
40.60	44	31.450	20.000	370	200	419	830	0,95	350	27,07	56

All data outputs are referred to power converter clocking frequency (PWM) >4kHz

Other windings and sizes on request

POWER DERATING BY INLET LIQUID TEMPERATURE

30°C (86°F) -3,5%

35°C (95°F) -6%

40°C (104°F) -10%

45°C (113°F) -12%

NOT COOLED VERSION IC410 on demand (POWER DERATING -55%)

SYNCHRONOUS PERMANENT MAGNETS MOTORS

RELIABILITY
HIGH TORQUE
HIGH DYNAMIC
HIGH TORQUE PEAK
VERY HIGH EFFICIENCY
EXCELLENT TORQUE/WEIGHT RATIO
SUITABLE FOR VECTOR DRIVES
IGBT COMPLIANT
WIDE RANGE OF CUSTOMIZATION AND
OPTIONS

IP PROTECTION
IP23, IP54 or IP55
COOLING METHOD
IC06, IC416, LIQUID

TYPICAL APPLICATIONS

FOOD BOXES EXTRUDERS
ENERGY RECOVERY SYSTEMS
LIFTING AND HANDLING SYSTEMS
PLASTIC AND RUBBER EXTRUDERS
PAPER AND CARDBOARD PRODUCTION
MACHINERY
PROCESSING AND CUTTING METAL PLATES
METAL WIRE PROCESSING MACHINERY
PACKAGING MACHINERY
PRINTING MACHINERY
TRACTION CONTROL
MACHINE TOOLS
COMPRESSORS



POWERTECH SY12 DRIVE 160

MEDIUM SPEED SYNCHRONOUS MOTORS

OVERVIEW

Rev. 1.4



IP PROTECTION	IP54
POLES	2p=12
THERMAL PROTECTION TYPE	PT100 (and other on request)
BALANCING, VIBRATION GRADE (EN 60034-14 / VDE 0530 part 14)	A (B on request)
INSULATION CLASS	F
COOLING METHOD	IC416A
STANDARD FAN DETAILS	3x400Vac 50/60Hz 0,26/0,33A
Amb. Cond.	0 + 40°C (32 + 104°F) 1000m ASL
TRANSDUCER	ENCODER OR RESOLVER (on request)
MOUNTING FORM	B3, B35, or other on request
BRAKE	up to 400 Nm (on request)
DE BEARING	BALL, ROLLER or INSULATED on request
NDE BEARING	BALL (insulated on request)
MAX ABSOLUTE SPEED	2000 r.p.m.
PAINTING SYSTEM	NITRO, POLYURETHANIC, C5M, on request

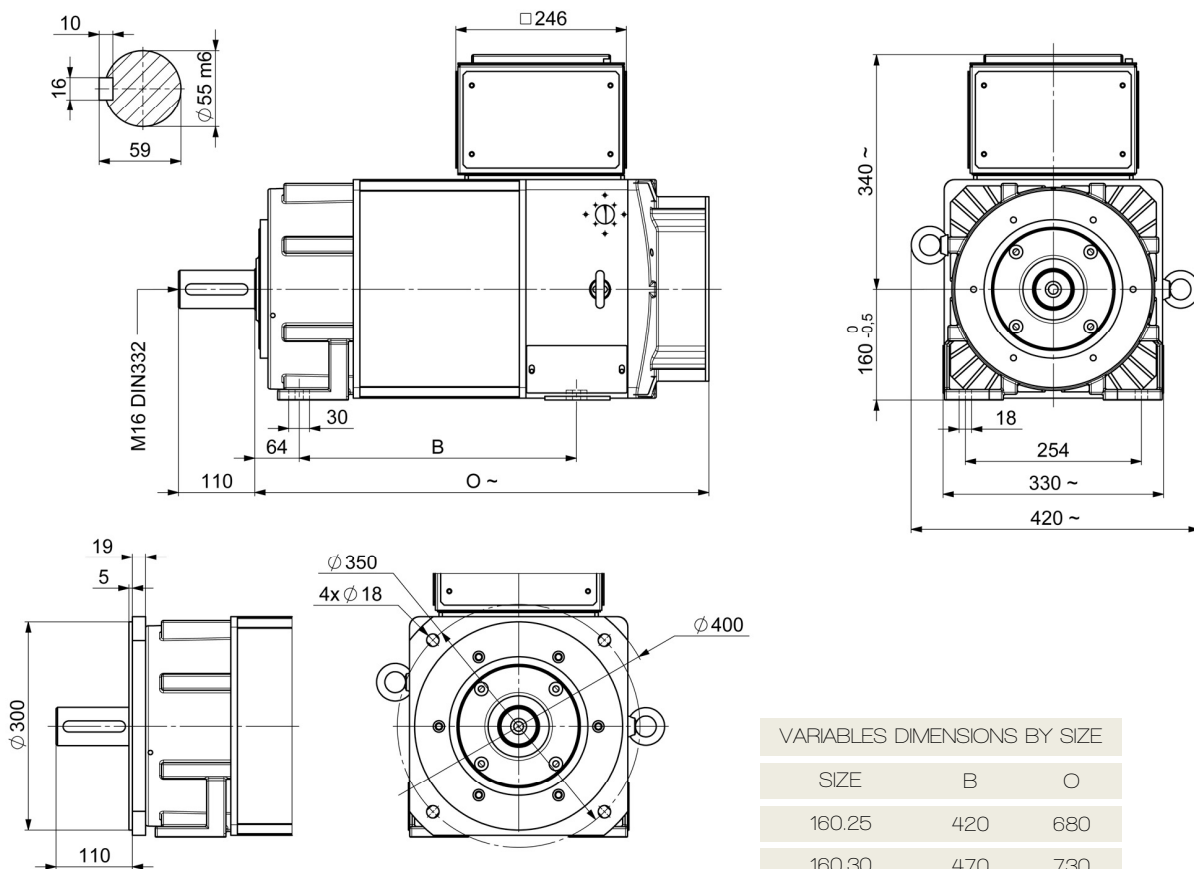

unit [mm]

400V SUPPLY STANDARD WINDING CODES

Speed Frequency	Type	Rotor Inertia	Max. absolute torque at 400V	Rated torque	Rated power	Rated voltage	Rated current	power factor	Efficiency
rpm Hz		Kgm ²	Nm	Nm	kW	V	A	cosφ	η
400 40Hz	160.25	0,31	1.100	370	15	365	27	0,99	0,92
	160.30	0,36	1.300	440	18	360	32	0,99	0,93
	160.35	0,40	1.500	515	22	380	36	0,99	0,93
	160.40	0,45	1.800	595	25	365	43	0,99	0,93
600 60Hz	160.25	0,31	1.200	360	22	360	39	0,97	0,94
	160.30	0,36	1.350	425	27	375	45	0,97	0,94
	160.35	0,40	1.600	505	31	375	52	0,98	0,94
	160.40	0,45	1.900	575	36	360	62	0,98	0,95
800 80Hz	160.25	0,31	1.200	340	28	355	50	0,97	0,95
	160.30	0,36	1.400	410	34	355	59	0,99	0,95
	160.35	0,40	1.650	475	40	370	66	0,99	0,95
	160.40	0,45	1.900	550	46	385	74	0,97	0,95
1000 100Hz	160.25	0,31	1.200	320	33	365	56	0,99	0,95
	160.30	0,36	1.500	385	40	395	63	0,99	0,95
	160.35	0,40	1.700	450	47	360	80	0,99	0,95
	160.40	0,45	2.000	520	54	360	93	0,97	0,95

All data outputs are referred to power converter clocking frequency (PWM) >4kHz

Other windings on request

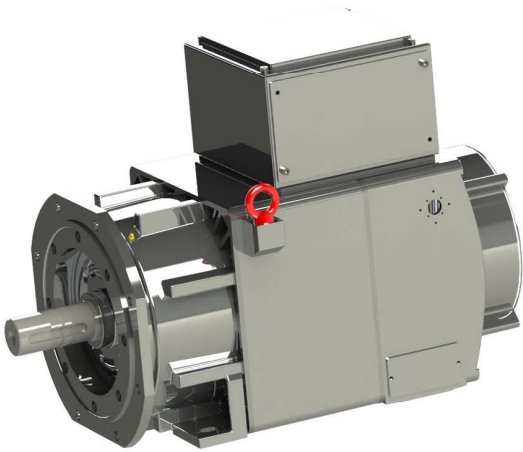

IP PROTECTION	IP54
POLES	2p=16
THERMAL PROTECTION TYPE	PT100 (and other on request)
BALANCING, VIBRATION GRADE (EN 60034-14 / VDE 0530 part 14)	A (B on request)
INSULATION CLASS	F
COOLING METHOD	IC416A
STANDARD FAN DETAILS	3x400Vac 50/60Hz 0,43/0,58A
Amb. Cond.	0 + 40°C (32 + 104°F) 1000m ASL
TRANSDUCER	ENCODER OR RESOLVER (on request)
MOUNTING FORM	B3, B35, or other on request
BRAKE	up to 600 Nm (on request)
DE BEARING	BALL, ROLLER or INSULATED on request
NDE BEARING	BALL (insulated on request)
MAX ABSOLUTE SPEED	1800 r.p.m.
PAINTING SYSTEM	NITRO, POLYURETHANIC, C5M, on request

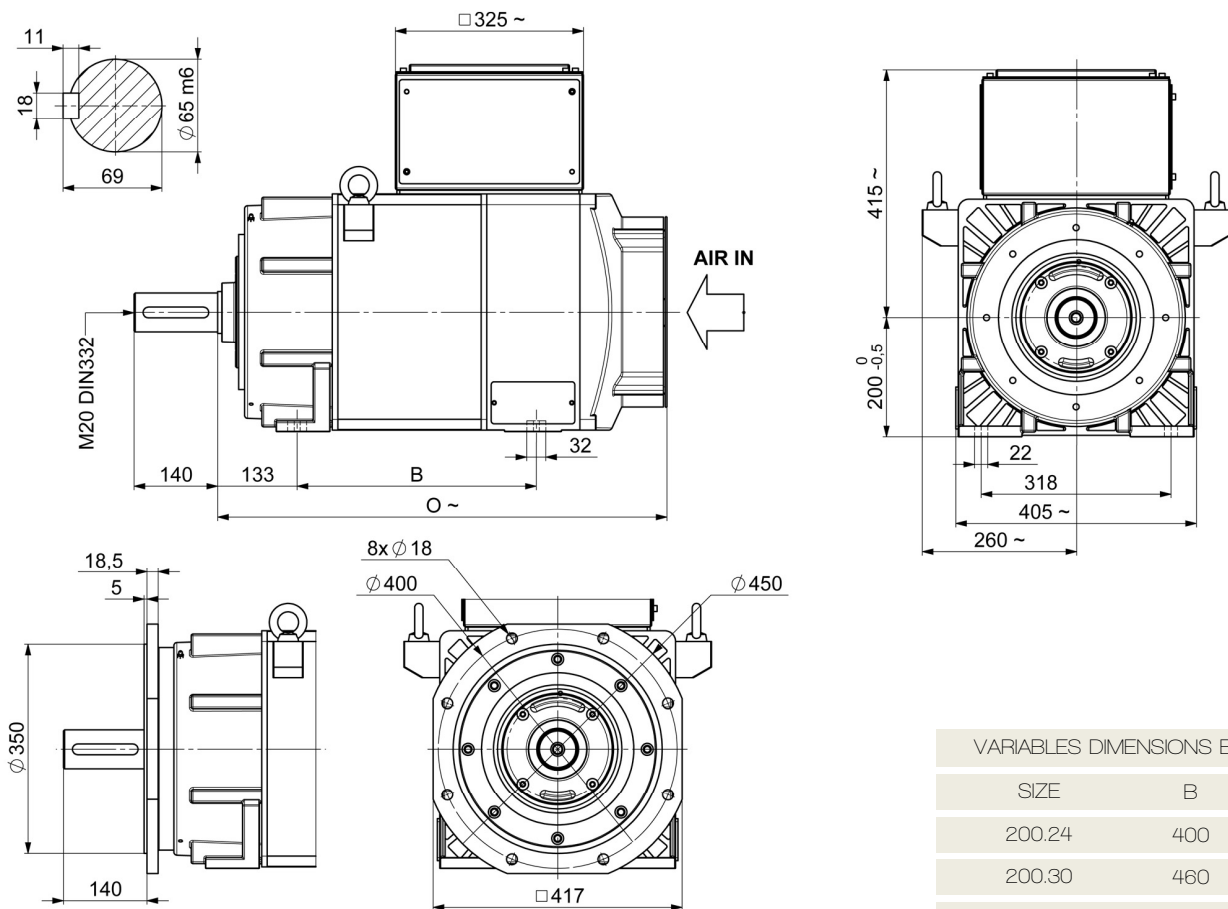

VARIABLES DIMENSIONS BY SIZE		
SIZE	B	O
200.24	400	760
200.30	460	820
200.36	520	880
200.42	580	940

unit [mm]

400V SUPPLY STANDARD WINDING CODES

Speed Frequency	Type	Rotor Inertia	Max. absolute torque at 400V	Rated torque	Rated power	Rated voltage	Rated current	power factor	Efficiency
rpm Hz		Kgm ²	Nm	Nm	kW	V	A	cosφ	η
400 53,3Hz	200.24	0,83	2.200	570	24	340	43	0,99	0,95
	200.30	1,03	2.700	715	30	360	51	0,99	0,95
	200.36	1,22	3.300	855	36	350	62	0,99	0,95
	200.42	1,42	3.900	1.000	42	365	70	0,99	0,95
600 80Hz	200.24	0,83	2.250	520	33	350	58	0,98	0,95
	200.30	1,03	2.800	655	41	340	74	0,99	0,96
	200.36	1,22	3.400	775	49	350	85	0,99	0,96
	200.42	1,42	4.000	915	57	380	94	0,97	0,96
800 106,7Hz	200.24	0,83	2.300	470	39	360	67	0,99	0,95
	200.30	1,03	2.850	585	49	355	84	0,99	0,95
	200.36	1,22	3.500	700	59	345	104	0,99	0,95
	200.42	1,42	4.100	810	68	360	115	0,99	0,96
1000 133,3Hz	200.24	0,83	2.250	413	44	355	75	0,99	0,95
	200.30	1,03	2.800	509	53	360	91	0,99	0,95
	200.36	1,22	3.400	609	64	340	116	0,98	0,95
	200.42	1,42	4.000	705	74	365	124	0,99	0,95

All data outputs are referred to power converter clocking frequency (PWM) >4kHz

Other windings on request

POWERTECH SY16 DRIVE 250

MEDIUM SPEED SYNCHRONOUS MOTORS

OVERVIEW

Rev. 1.4

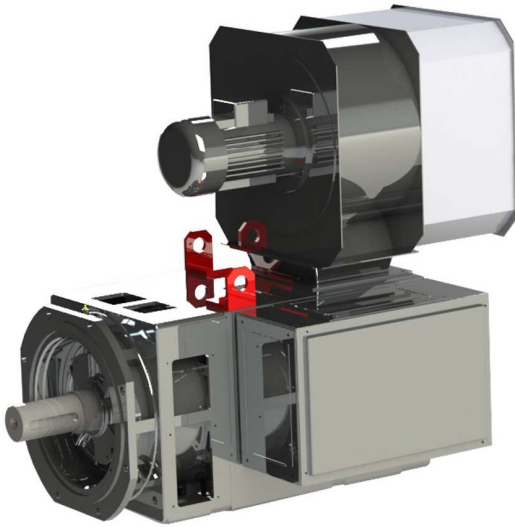

IP PROTECTION	IP54
POLES	2p=16
THERMAL PROTECTION TYPE	PT100 (and other on request)
BALANCING, VIBRATION GRADE (EN 60034-14 / VDE 0530 part 14)	A (B on request)
INSULATION CLASS	F
COOLING METHOD	IC416R (with filter on request)
STANDARD FAN DETAILS	3x230/400Vac 50Hz 11,5/6,6A
Amb. Cond.	0 + 40°C (32 + 104°F) 1000m ASL
TRANSDUCER	ENCODER OR RESOLVER (on request)
MOUNTING FORM	B3, B35, or other on request
BRAKE	up to 2400 Nm (on request)
DE BEARING	BALL (ROLLER on request)
NDE BEARING	BALL (insulated on request)
MAX ABSOLUTE SPEED	1500 r.p.m.
PAINTING SYSTEM	NITRO, POLYURETHANIC, C5M, on request

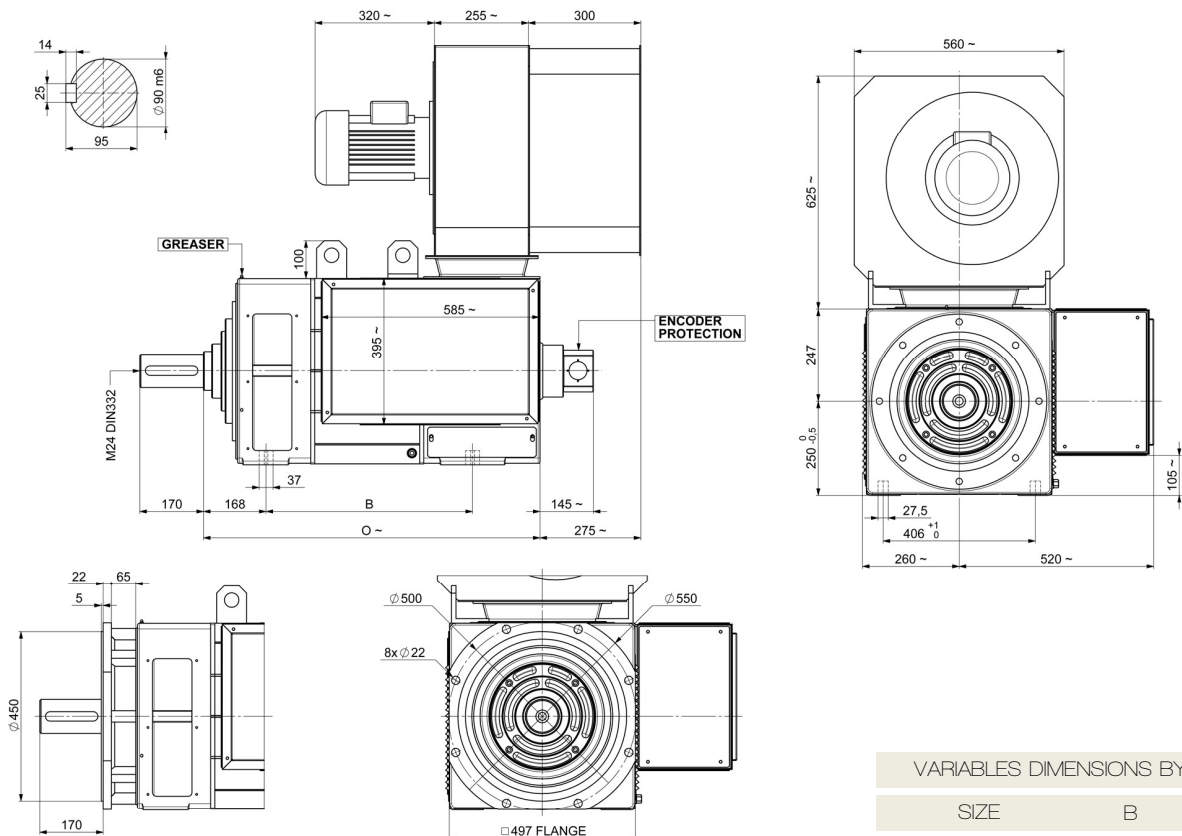

VARIABLES DIMENSIONS BY SIZE		
SIZE	B	O
250.32	591	940
250.40	671	1020
250.48	751	1100
250.56	831	1180

unit [mm]

400V SUPPLY STANDARD WINDING CODES

Speed Frequency	Type	Rotor Inertia	Max. absolute torque at 400V	Rated torque	Rated power	Rated voltage	Rated current	power factor	Efficiency
rpm Hz		Kgm ²	Nm	Nm	kW	V	A	cos ϕ	η
400 53,3Hz	250.32	2,5	4.650	1.530	64	355	115	0,95	0,95
	250.40	3,3	5.800	1.810	80	355	143	0,95	0,96
	250.48	4,0	7.000	2.300	96	355	170	0,96	0,96
	250.56	4,3	8.150	2.680	112	360	199	0,95	0,96
600 80Hz	250.32	2,5	4.650	1.410	88	355	157	0,95	0,96
	250.40	3,2	5.800	1.760	110	360	195	0,95	0,96
	250.48	3,8	7.000	2.120	133	355	237	0,95	0,96
	250.56	4,3	8.200	2.470	155	355	275	0,96	0,96
800 106,7Hz	250.32	2,5	4.650	1.200	101	355	178	0,96	0,96
	250.40	3,2	5.800	1.500	125	360	216	0,97	0,96
	250.48	3,8	7.000	1.790	150	330	282	0,97	0,96
	250.56	4,3	8.200	2.080	175	350	314	0,96	0,96

All data outputs are referred to power converter clocking frequency (PWM) >4kHz

Other windings on request

400V SUPPLY STANDARD WINDING CODES

Speed Frequency	Type	Rotor Inertia	Max. absolute torque at 400V	Rated torque	Rated power	Rated voltage	Rated current	power factor	Efficiency
rpm Hz		Kgm ²	Nm	Nm	kW	V	A	cos ϕ	η
400 53,3Hz	315.32	8,3	6.500	2.760	115	380	196	0,93	0,96
	315.40	9,3	8.000	3.440	144	375	244	0,94	0,96
	315.48	10,4	9.500	4.130	173	360	305	0,94	0,96
	315.56	11,4	11.500	4.810	201	365	349	0,95	0,96
600 80Hz	315.32	8,3	6.500	2.470	155	355	275	0,95	0,96
	315.40	9,3	8.000	3.110	195	365	340	0,94	0,97
	315.48	10,4	9.500	3.720	234	370	401	0,94	0,97
	315.56	11,4	11.500	4.340	273	350	491	0,95	0,97
800 106,7Hz	315.32	8,3	6.500	2.160	181	355	322	0,95	0,96
	315.40	9,3	8.000	2.670	224	365	383	0,96	0,96
	315.48	10,4	9.500	3.230	270	350	481	0,96	0,97
	315.56	11,4	11.500	3.760	315	360	550	0,95	0,97

All data outputs are referred to power converter clocking frequency (PWM) >4kHz

Other windings on request

POWERTECH SY12 TETRAVEC 160

MEDIUM SPEED SYNCHRONOUS MOTORS

OVERVIEW

Rev. 1.4

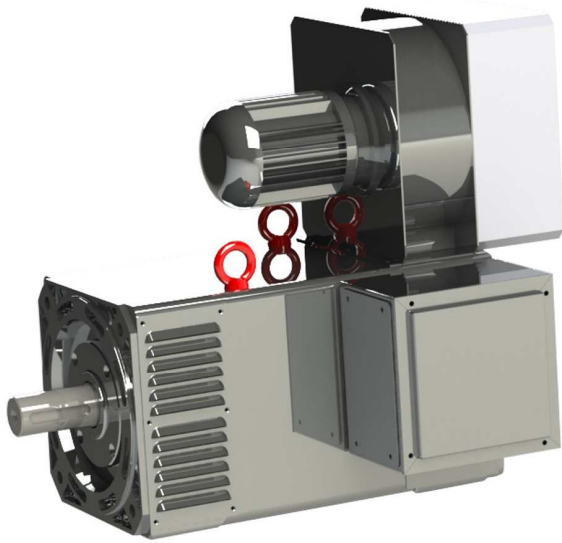

IP PROTECTION	IP23
POLES	2p=12
THERMAL PROTECTION TYPE	PT100 (and other on request)
BALANCING, VIBRATION GRADE (EN 60034-14 / VDE 0530 part 14)	A (B on request)
INSULATION CLASS	F
COOLING METHOD	IC06 (with filter on request)
STANDARD FAN DETAILS	3x230/400Vac 50Hz 4,5/2,6A
Amb. Cond.	0 + 40°C (32 + 104°F) 1000m ASL
TRANSDUCER	ENCODER OR RESOLVER (on request)
MOUNTING FORM	B3, B35, or other on request
BRAKE	up to 400 Nm (on request)
DE BEARING	BALL (ROLLER on request)
NDE BEARING	BALL (insulated on request)
MAX ABSOLUTE SPEED	2000 r.p.m.
PAINTING SYSTEM	NITRO, POLYURETHANIC, C5M, on request

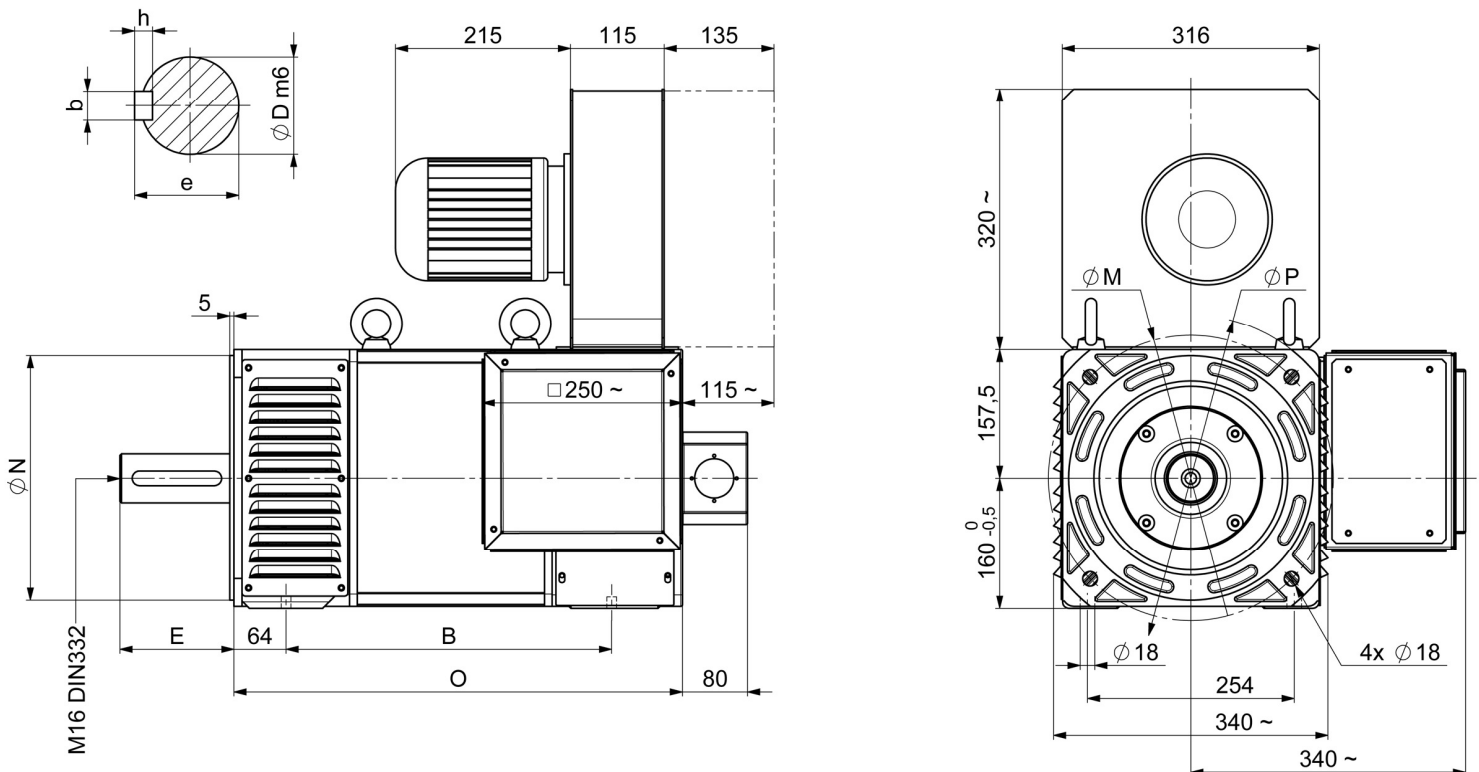

VARIABLES DIMENSIONS BY SIZE

SIZE	B	O
160.25	420	571
160.30	470	621
160.35	520	671
160.40	570	721

FLANGE

P	M	N
400	300	250
400	350	300

SHAFT AND KEYWAY

DxE	bxh	e
60x140	18x11	64

unit [mm]

400V SUPPLY STANDARD WINDING CODES

Speed Frequency	Type	Rotor Inertia	Max. absolute torque at 400V	Rated torque	Rated power	Rated voltage	Rated current	power factor	Efficiency
rpm Hz		Kgm ²	Nm	Nm	kW	V	A	cosφ	η
400 40Hz	160.25	0,31	1.100	520	22	370	39	0,98	0,90
	160.30	0,36	1.300	630	26	370	46	0,98	0,91
	160.35	0,40	1.500	735	31	365	54	0,98	0,91
	160.40	0,45	1.800	845	35	370	62	0,98	0,91
600 60Hz	160.25	0,31	1.200	525	33	370	57	0,97	0,93
	160.30	0,36	1.350	630	40	360	70	0,97	0,93
	160.35	0,40	1.600	735	46	385	76	0,97	0,93
	160.40	0,45	1.900	835	53	365	92	0,97	0,93
800 80Hz	160.25	0,31	1.200	520	43	365	75	0,97	0,94
	160.30	0,36	1.400	620	52	365	90	0,97	0,94
	160.35	0,40	1.650	720	60	385	99	0,96	0,94
	160.40	0,45	1.900	830	69	390	112	0,97	0,94
1000 100Hz	160.25	0,31	1.200	500	52	380	87	0,96	0,95
	160.30	0,36	1.500	605	63	365	109	0,96	0,95
	160.35	0,40	1.700	700	73	370	125	0,97	0,95
	160.40	0,45	2.000	800	84	365	145	0,96	0,95

All data outputs are referred to power converter clocking frequency (PWM) >4kHz

Other windings on request

POWERTECH SY16 TETRAVEC 200

MEDIUM SPEED SYNCHRONOUS MOTORS

OVERVIEW

Rev. 1.4

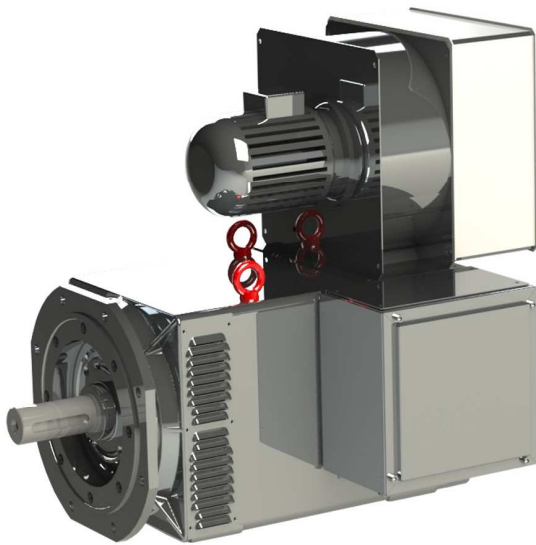

IP PROTECTION	IP23
POLES	2p=16
THERMAL PROTECTION TYPE	PT100 (and other on request)
BALANCING, VIBRATION GRADE (EN 60034-14 / VDE 0530 part 14)	A (B on request)
INSULATION CLASS	F
COOLING METHOD	IC06 (with filter on request)
STANDARD FAN DETAILS	3x230/400Vac 50Hz 5,7/3,3A
Amb. Cond.	0 + 40°C (32 + 104°F) 1000m ASL
TRANSDUCER	ENCODER OR RESOLVER (on request)
MOUNTING FORM	B3, B35, or other on request
BRAKE	up to 600 Nm (on request)
DE BEARING	BALL (ROLLER on request)
NDE BEARING	BALL (insulated on request)
MAX ABSOLUTE SPEED	1800 r.p.m.
PAINTING SYSTEM	NITRO, POLYURETHANIC, C5M, on request

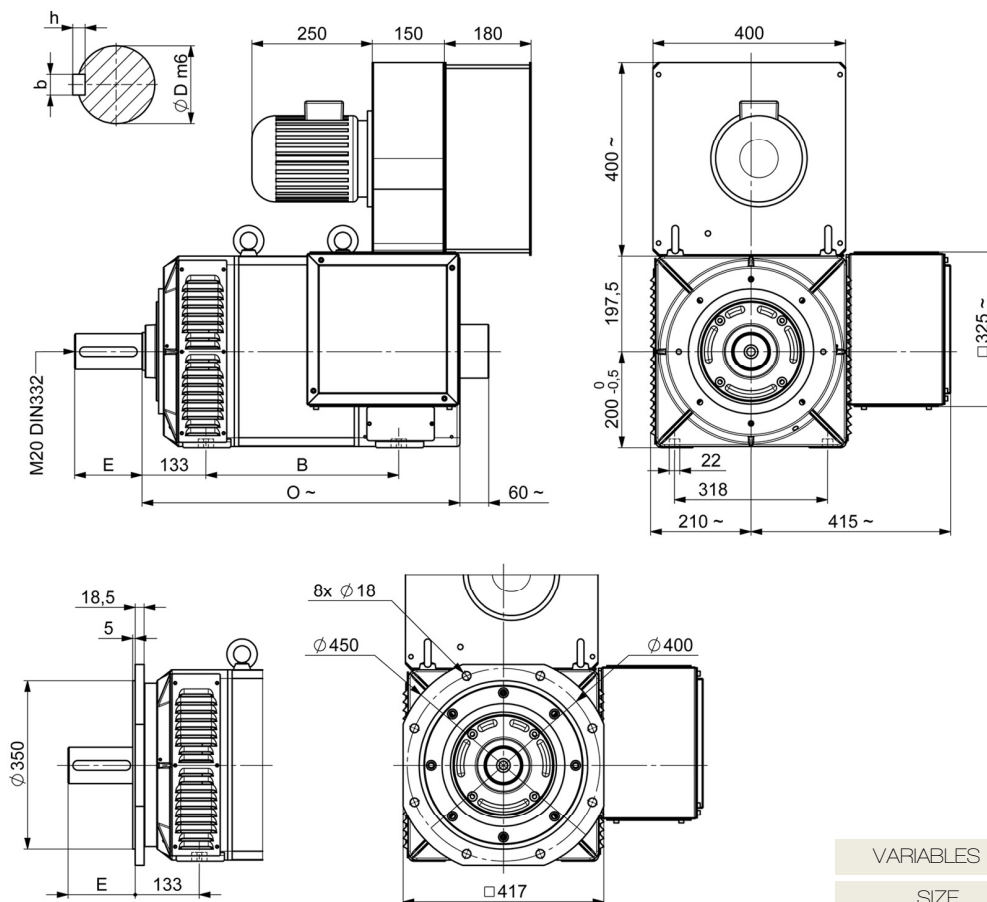

SHAFT AND KEYWAY

DxE	b x h
75x140	20x12

unit [mm]

VARIABLES DIMENSIONS BY SIZE

SIZE	B	O
200.24	400	660
200.30	460	720
200.36	520	780
200.42	580	840

400V SUPPLY STANDARD WINDING CODES

Speed Frequency	Type	Rotor Inertia	Max. absolute torque at 400V	Rated torque	Rated power	Rated voltage	Rated current	power factor	Efficiency
rpm Hz		Kgm ²	Nm	Nm	kW	V	A	cos φ	η
400 53,3Hz	200.24	0,83	2.200	1.060	44	365	80	0,95	0,93
	200.30	1,03	2.700	1.320	55	380	95	0,96	0,93
	200.36	1,22	3.300	1.580	66	370	115	0,96	0,93
	200.42	1,42	3.900	1.830	77	380	130	0,96	0,93
600 80Hz	200.24	0,83	2.250	1.040	65	370	114	0,95	0,94
	200.30	1,03	2.800	1.290	81	355	145	0,96	0,95
	200.36	1,22	3.400	1.550	97	365	170	0,96	0,95
	200.42	1,42	4.000	1.800	113	390	185	0,96	0,95
800 106,7Hz	200.24	0,83	2.300	1.010	84	380	142	0,95	0,95
	200.30	1,03	2.850	1.235	104	365	179	0,96	0,95
	200.36	1,22	3.500	1.500	125	360	219	0,96	0,95
	200.42	1,42	4.100	1.730	145	370	246	0,97	0,96
1000 133,3Hz	200.24	0,83	2.250	955	100	370	171	0,95	0,96
	200.30	1,03	2.800	1.185	124	370	209	0,97	0,96
	200.36	1,22	3.400	1.435	150	350	270	0,96	0,96
	200.42	1,42	4.000	1.670	175	380	290	0,96	0,96

All data outputs are referred to power converter clocking frequency (PWM) >4kHz

Other windings on request

POWERTECH SY16 TETRAVEC 250

MEDIUM SPEED SYNCHRONOUS MOTORS

OVERVIEW

Rev. 1.4

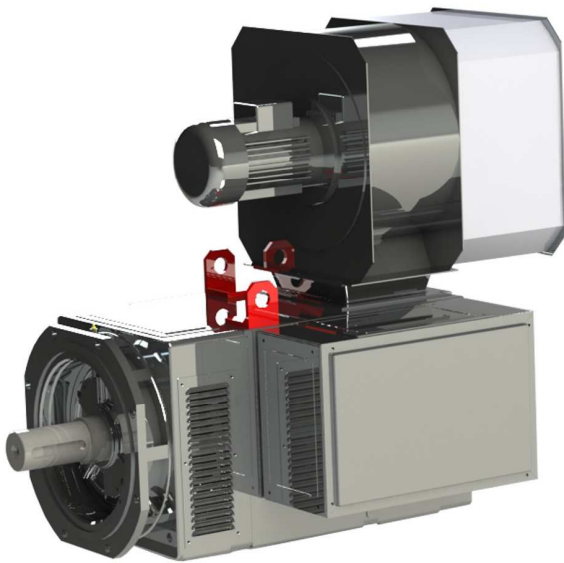

IP PROTECTION	IP23
POLES	2p=16
THERMAL PROTECTION TYPE	PT100 (and other on request)
BALANCING, VIBRATION GRADE (EN 60034-14 / VDE 0530 part 14)	A (B on request)
INSULATION CLASS	F
COOLING METHOD	IC06 (with filter on request)
STANDARD FAN DETAILS	3x230/400Vac 50Hz 11,5/6,6A
Amb. Cond.	0 + 40°C (32 + 104°F) 1000m ASL
TRANSDUCER	ENCODER OR RESOLVER (on request)
MOUNTING FORM	B3, B35, or other on request
BRAKE	up to 2400 Nm (on request)
DE BEARING	BALL (ROLLER on request)
NDE BEARING	BALL (insulated on request)
MAX ABSOLUTE SPEED	1500 r.p.m.
PAINTING SYSTEM	NITRO, POLYURETHANIC, C5M, on request

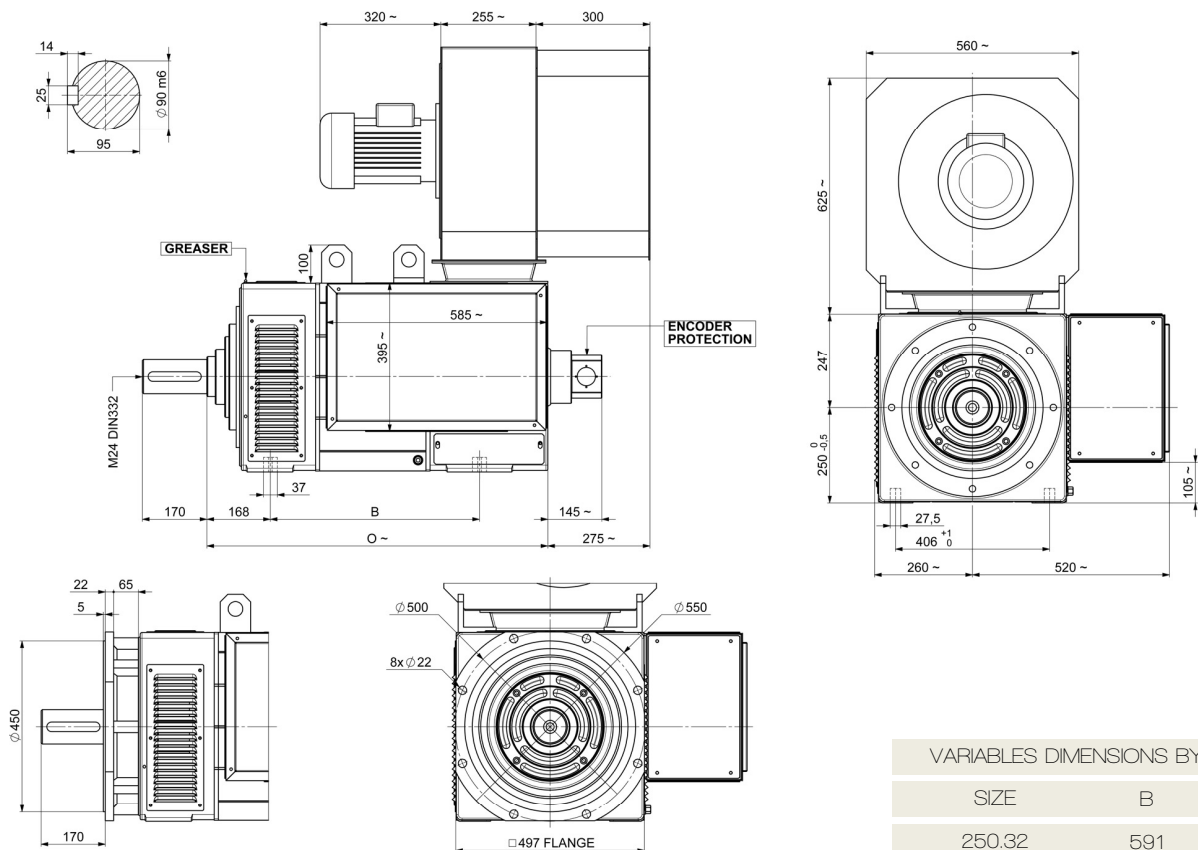

VARIABLES DIMENSIONS BY SIZE		
SIZE	B	O
250.32	591	940
250.40	671	1020
250.48	751	1100
250.56	831	1180

unit [mm]

400V SUPPLY STANDARD WINDING CODES

Speed Frequency	Type	Rotor Inertia	Max. absolute torque at 400V	Rated torque	Rated power	Rated voltage	Rated current	power factor	Efficiency
rpm Hz		Kgm ²	Nm	Nm	kW	V	A	cosφ	η
400 53,3Hz	250.32	2,5	4.650	2.400	100	370	182	0,91	0,94
	250.40	3,3	5.800	3.000	126	370	225	0,92	0,95
	250.48	4,0	7.000	3.630	152	380	268	0,91	0,95
	250.56	4,3	8.150	4.210	176	375	313	0,92	0,95
600 80Hz	250.32	2,5	4.650	2.350	148	375	262	0,91	0,96
	250.40	3,2	5.800	2.930	184	375	323	0,92	0,96
	250.48	3,8	7.000	3.520	221	370	392	0,92	0,96
	250.56	4,3	8.200	4.100	258	370	457	0,92	0,96
800 106,7Hz	250.32	2,5	4.650	2.270	190	380	332	0,91	0,96
	250.40	3,2	5.800	2.840	238	380	410	0,92	0,96
	250.48	3,8	7.000	3.400	285	350	532	0,92	0,96
	250.56	4,3	8.200	3.970	333	370	591	0,91	0,96

All data outputs are referred to power converter clocking frequency (PWM) >4kHz

Other windings on request

POWERTECH SY16 TETRAVEC 315

MEDIUM SPEED SYNCHRONOUS MOTORS

OVERVIEW

Rev. 1.4



IP PROTECTION	IP23
POLES	2p=16
THERMAL PROTECTION TYPE	PT100 (and other on request)
BALANCING, VIBRATION GRADE (EN 60034-14 / VDE 0530 part 14)	A (B on request)
INSULATION CLASS	F
COOLING METHOD	IC06 (with filter on request)
STANDARD FAN DETAILS	3x230/400Vac 50Hz 19,6/11,3A
Amb. Cond.	0 + 40°C (32 + 104°F) 1000m ASL
TRANSDUCER	ENCODER OR RESOLVER (on request)
MOUNTING FORM	B3, B35, or other on request
BRAKE	up to 2500 Nm (on request)
DE BEARING	BALL (ROLLER on request)
NDE BEARING	BALL (INSULATED)
MAX ABSOLUTE SPEED	1300 r.p.m.
PAINTING SYSTEM	NITRO, POLYURETHANIC, C5M, on request

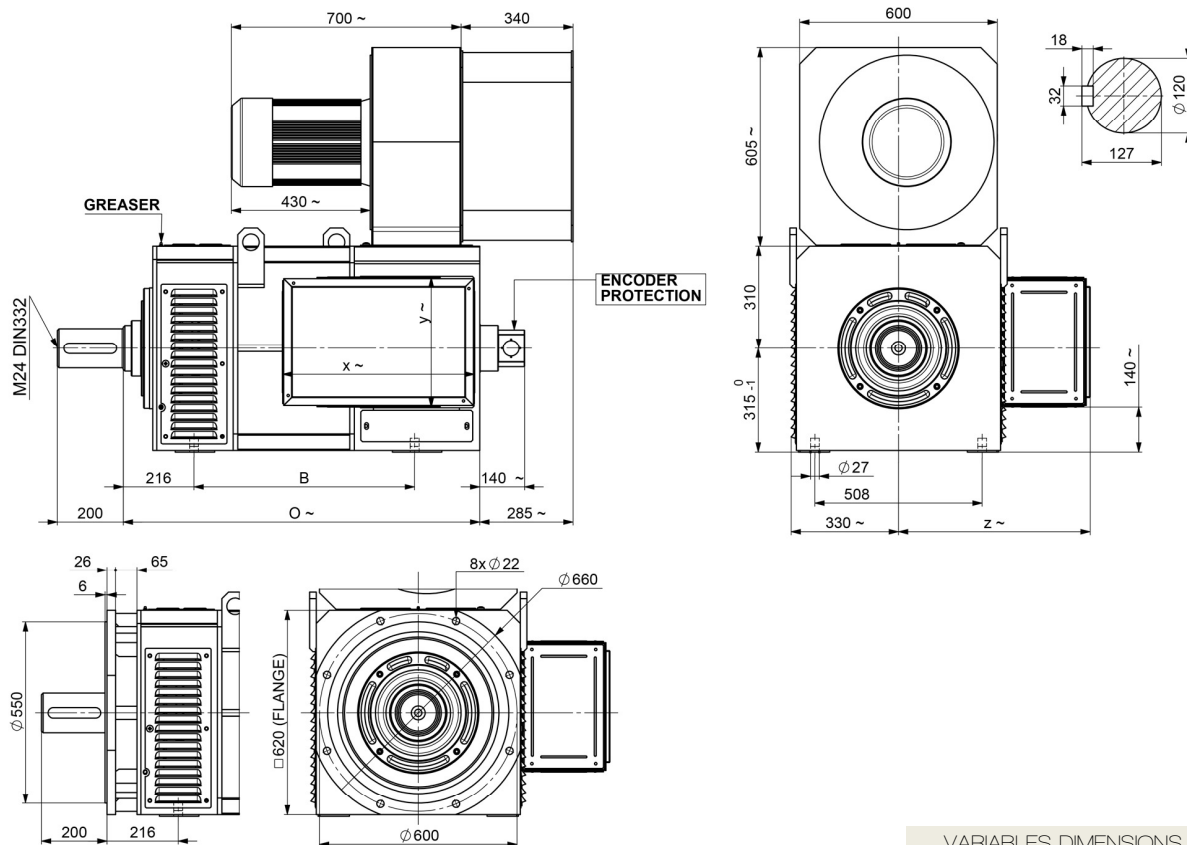

TERMINAL BOX DIMENSIONS			
TYPE	x	x	z
STANDARD	585	400	585
INCREASED (on request)	645	534	585

VARIABLES DIMENSIONS BY SIZE		
SIZE	B	O
315.32	650	1070
315.40	730	1150
315.48	810	1230
315.56	890	1310

unit [mm]

400V SUPPLY STANDARD WINDING CODES

Speed Frequency	Type	Rotor Inertia	Max. absolute torque at 400V	Rated torque	Rated power	Rated voltage	Rated current	power factor	Efficiency
rpm Hz		Kgm ²	Nm	Nm	kW	V	A	cos ϕ	η
400 53,3Hz	315.32	8,3	6.500	4.240	178	385	307	0,92	0,95
	315.40	9,3	8.000	5.300	222	385	383	0,91	0,95
	315.48	10,4	9.500	6.320	265	365	478	0,92	0,95
	315.56	11,4	11.500	7.360	308	370	546	0,92	0,95
600 80Hz	315.32	8,3	6.500	4.150	260	365	469	0,92	0,96
	315.40	9,3	8.000	5.170	325	370	576	0,92	0,96
	315.48	10,4	9.500	6.240	392	375	685	0,92	0,96
	315.56	11,4	11.500	7.240	455	355	834	0,92	0,96
800 106,7Hz	315.32	8,3	6.500	4.000	335	360	605	0,92	0,96
	315.40	9,3	8.000	5.000	418	375	724	0,92	0,96
	315.48	10,4	9.500	6.000	502	360	906	0,92	0,96
	315.56	11,4	11.500	6.970	584	365	1033	0,93	0,97

All data outputs are referred to power converter clocking frequency (PWM) >4kHz

Other windings on request

POWERTECH SY12 FLUID 160

MEDIUM SPEED SYNCHRONOUS MOTORS

OVERVIEW

Rev. 1.3



IP PROTECTION	IP54 (IP55 on request)
POLES	2p=12
THERMAL PROTECTION TYPE	PT100 (and other on request)
BALANCING, VIBRATION GRADE (EN 60034-14 / VDE 0530 part 14)	A (B on request)
INSULATION CLASS	F
COOLING METHOD	LIQUID (flow rate by size) 10 + 25°C (50 + 77 °F) + GLYCOL 20%
Amb. Cond.	0 + 40°C (32 + 104°F) 1000m ASL
TRANSDUCER	ENCODER OR RESOLVER (on request)
MOUNTING FORM	B3, B35, or other on request
BRAKE	up to 400 Nm (on request)
DE BEARING	BALL (ROLLER request)
NDE BEARING	BALL (insulated on request)
MAX ABSOLUTE SPEED	2000 r.p.m.
PAINTING SYSTEM	NITRO, POLYURETHANIC, C5M, on request

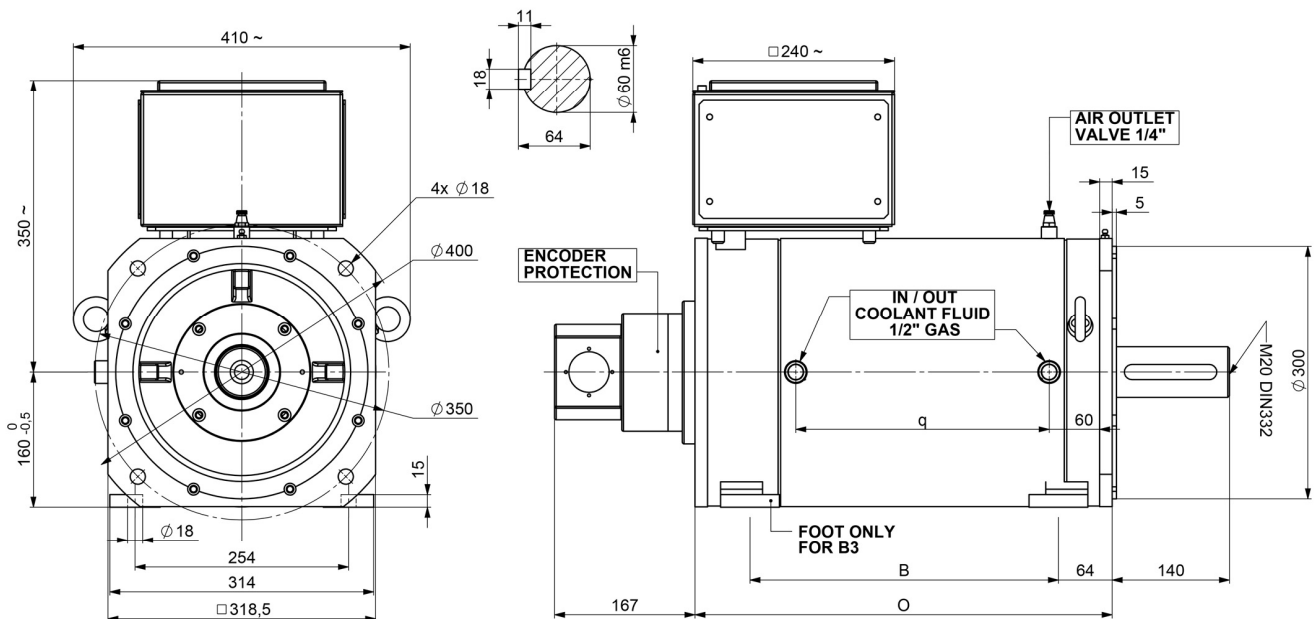

VARIABLES DIMENSIONS BY SIZE

SIZE	B	O	q
160.25	387	520	321,5
160.30	437	570	371,5
160.35	487	620	421,5
160.40	537	670	471,5

unit [mm]

400V SUPPLY STANDARD WINDING CODES

Speed Frequency	Type	Rotor Inertia	Max. absolute torque at 400V	Rated torque	Rated power	Rated voltage	Rated current	power factor	Efficiency	Liquid flow rate
rpm Hz		Kgm ²	Nm	Nm	kW	V	A	cosφ	η	L/1'
400 40Hz	160.25	0,31	1.100	460	19	370	33	0,98	0,91	14
	160.30	0,36	1.300	550	23	370	40	0,98	0,92	16
	160.35	0,40	1.500	640	27	380	45	0,99	0,92	17
	160.40	0,45	1.800	740	31	370	53	0,98	0,92	18
600 60Hz	160.25	0,31	1.200	450	28	370	49	0,97	0,94	14
	160.30	0,36	1.350	540	34	360	60	0,97	0,94	16
	160.35	0,40	1.600	630	40	380	65	0,98	0,94	17
	160.40	0,45	1.900	720	45	365	78	0,97	0,94	18
800 80Hz	160.25	0,31	1.200	440	37	365	64	0,97	0,94	14
	160.30	0,36	1.400	520	44	360	76	0,98	0,95	16
	160.35	0,40	1.650	610	51	380	84	0,97	0,95	17
	160.40	0,45	1.900	700	59	385	95	0,98	0,95	18
1000 100Hz	160.25	0,31	1.200	425	44	380	74	0,97	0,95	14
	160.30	0,36	1.500	510	53	360	92	0,97	0,95	16
	160.35	0,40	1.700	595	62	370	105	0,97	0,95	17
	160.40	0,45	2.000	675	70	360	122	0,97	0,95	18

All data outputs are referred to power converter clocking frequency (PWM) >4kHz

Other windings on request

POWER DERATING BY INLET LIQUID TEMPERATURE

30°C (86°F) -3,5%

35°C (95°F) -6%

40°C (104°F) -10%

45°C (113°F) -12%

POWERTECH SY16 FLUID 200

MEDIUM SPEED SYNCHRONOUS MOTORS

OVERVIEW

Rev. 1.3



IP PROTECTION	IP54 (IP55 on request)
POLES	2p=16
THERMAL PROTECTION TYPE	PT100 (and other on request)
BALANCING, VIBRATION GRADE (EN 60034-14 / VDE 0530 part 14)	A (B on request)
INSULATION CLASS	F
COOLING METHOD	LIQUID (flow rate by size) 10 + 25°C (50 + 77 °F) + GLYCOL 20%
Amb. Cond.	0 + 40°C (32 + 104°F) 1000m ASL
TRANSDUCER	ENCODER OR RESOLVER (on request)
MOUNTING FORM	B3, B35, or other on request
BRAKE	up to 600 Nm (on request)
DE BEARING	BALL (ROLLER on request)
NDE BEARING	BALL (insulated on request)
MAX ABSOLUTE SPEED	1800 r.p.m.
PAINTING SYSTEM	NITRO, POLYURETHANIC, C5M, on request

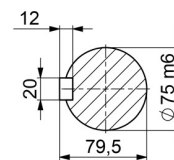
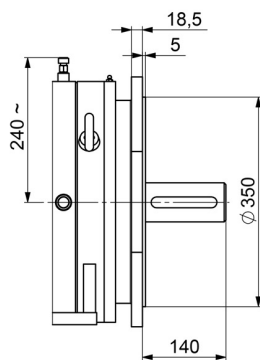
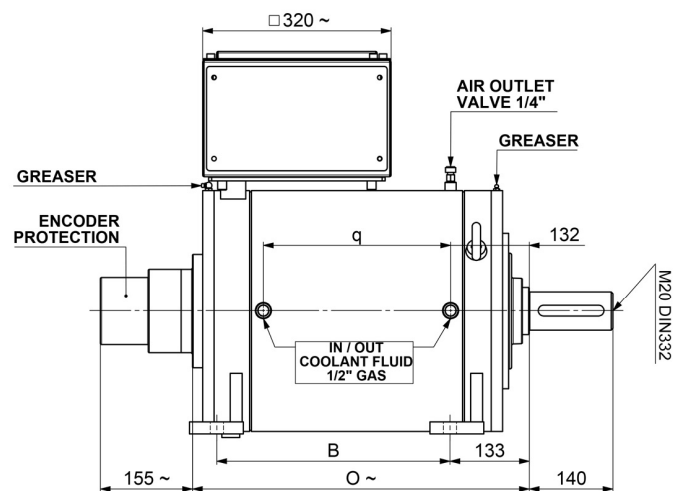
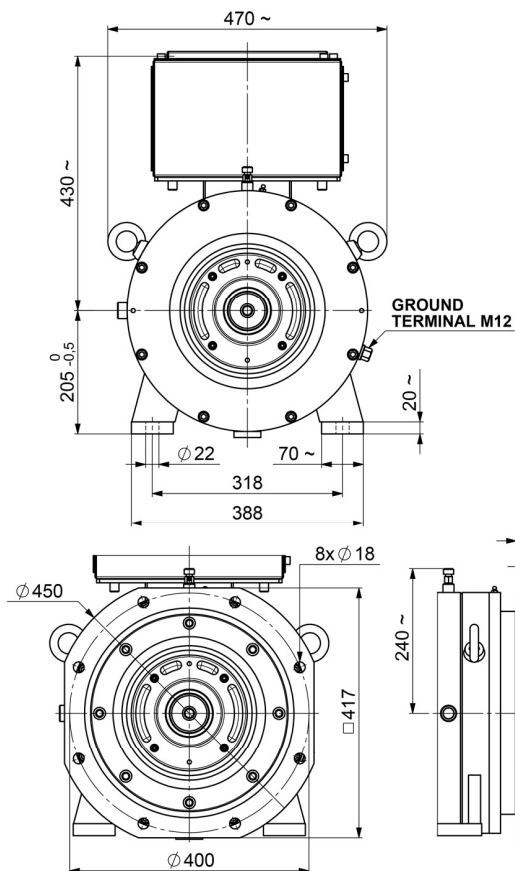

VARIABLES DIMENSIONS BY SIZE

SIZE	B	O	q
200.24	390	565	313
200.30	450	625	373
200.36	510	685	433
200.42	570	745	493

unit [mm]

400V SUPPLY STANDARD WINDING CODES

Speed Frequency	Type	Rotor Inertia	Max. absolute torque at 400V	Rated torque	Rated power	Rated voltage	Rated current	power factor	Efficiency	Liquid flow rate
rpm Hz		Kgm ²	Nm	Nm	kW	V	A	cosφ	η	L/1'
400 53,3Hz	200.24	0,83	2.200	900	38	360	68	0,95	0,93	19
	200.30	1,03	2.700	1.150	47	370	80	0,97	0,94	21
	200.36	1,22	3.300	1.330	56	360	98	0,98	0,94	23
	200.42	1,42	3.900	1.570	66	375	110	0,97	0,94	25
600 80Hz	200.24	0,83	2.250	875	55	370	95	0,95	0,95	19
	200.30	1,03	2.800	1.095	69	355	123	0,96	0,95	21
	200.36	1,22	3.400	1.315	82	360	143	0,97	0,95	23
	200.42	1,42	4.000	1.530	96	385	157	0,97	0,95	25
800 106,7Hz	200.24	0,83	2.300	830	69	370	117	0,97	0,95	19
	200.30	1,03	2.850	1.035	87	365	149	0,97	0,96	21
	200.36	1,22	3.500	1.240	104	355	181	0,97	0,96	23
	200.42	1,42	4.100	1.430	120	370	204	0,97	0,95	25
1000 133,3Hz	200.24	0,83	2.250	780	81	365	140	0,96	0,96	19
	200.30	1,03	2.800	965	101	365	170	0,98	0,96	21
	200.36	1,22	3.400	1.150	122	345	219	0,97	0,96	23
	200.42	1,42	4.000	1.330	139	375	236	0,97	0,94	25

All data outputs are referred to power converter clocking frequency (PWM) >4kHz

Other windings on request

POWER DERATING BY INLET LIQUID TEMPERATURE

30°C (86°F) -3,5%

35°C (95°F) -6%

40°C (104°F) -10%

45°C (113°F) -12%

POWERTECH SY16 FLUID 250

MEDIUM SPEED SYNCHRONOUS MOTORS

OVERVIEW

Rev. 1.3



IP PROTECTION	IP54 (IP55 on request)
POLES	2p=16
THERMAL PROTECTION TYPE	PT100 (and other on request)
BALANCING, VIBRATION GRADE (EN 60034-14 / VDE 0530 part 14)	A (B on request)
INSULATION CLASS	F
COOLING METHOD	LIQUID (flow rate by size) 10 + 25°C (50 + 77 °F) + GLYCOL 20%
Amb. Cond.	0 + 40°C (32 + 104°F) 1000m ASL
TRANSDUCER	ENCODER OR RESOLVER (on request)
MOUNTING FORM	B3, B35, or other on request
BRAKE	up to 2400 Nm (on request)
DE BEARING	BALL (ROLLER request)
NDE BEARING	BALL (insulated on request)
MAX ABSOLUTE SPEED	1500 r.p.m.
PAINTING SYSTEM	NITRO, POLYURETHANIC, C5M, on request

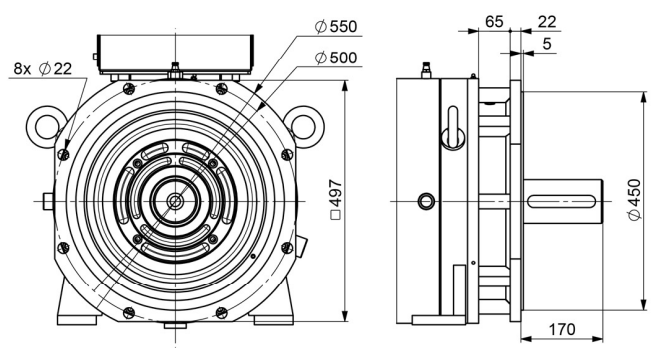
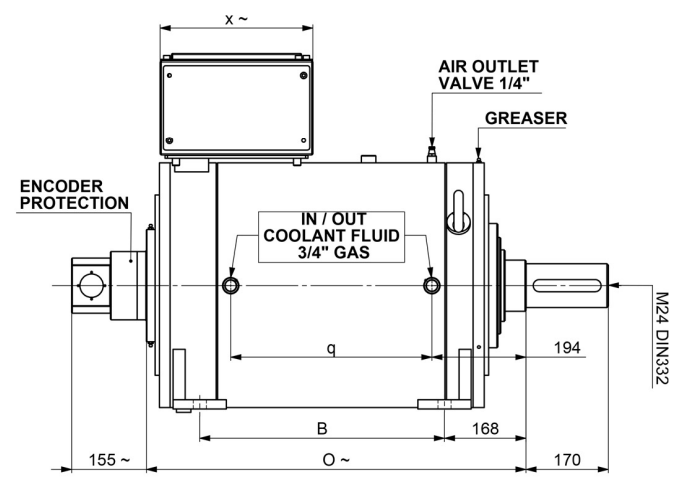
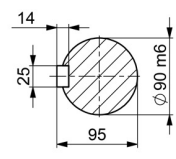
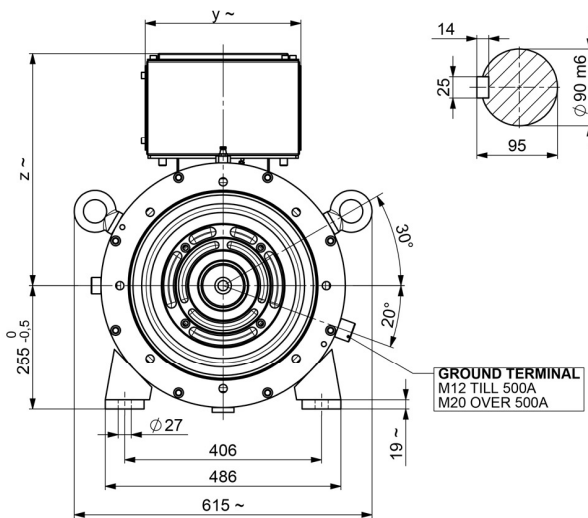

TERMINAL BOX DIMENSIONS			
MOTOR CURRENT	x	x	z
TILL 500 A	315	320	480
OVER 500 A	585	395	535

VARIABLES DIMENSIONS BY SIZE			
SIZE	B	O	q
250.32	545	825	455
250.40	625	905	535
250.48	705	985	615
250.56	785	1065	695

unit [mm]

400V SUPPLY STANDARD WINDING CODES

Speed Frequency	Type	Rotor Inertia	Max. absolute torque at 400V	Rated torque	Rated power	Rated voltage	Rated current	power factor	Efficiency	Liquid flow rate
rpm Hz		Kgm ²	Nm	Nm	kW	V	A	cos ϕ	η	L/1'
400 53,3Hz	250.32	2,5	4.650	2.180	90	370	164	0,90	0,95	25
	250.40	3,3	5.800	2.730	114	370	209	0,90	0,95	28
	250.48	4,0	7.000	3.280	137	375	249	0,89	0,95	30
	250.56	4,3	8.150	3.820	160	375	290	0,89	0,95	32
600 80Hz	250.32	2,5	4.650	2.120	133	375	241	0,89	0,96	25
	250.40	3,2	5.800	2.640	165	375	298	0,89	0,96	28
	250.48	3,8	7.000	3.180	200	370	362	0,90	0,96	30
	250.56	4,3	8.200	3.690	232	370	421	0,89	0,96	32
800 106,7Hz	250.32	2,5	4.650	2.010	168	380	302	0,88	0,96	25
	250.40	3,2	5.800	2.510	210	380	372	0,89	0,96	28
	250.48	3,8	7.000	3.010	252	350	482	0,90	0,96	30
	250.56	4,3	8.200	3.510	294	365	536	0,90	0,96	32

All data outputs are referred to power converter clocking frequency (PWM) >4kHz

Other windings on request

POWER DERATING BY INLET LIQUID TEMPERATURE

30°C (86°F) -3,5%

35°C (95°F) -6%

40°C (104°F) -10%

45°C (113°F) -12%

POWERTECH SY16 FLUID 315

MEDIUM SPEED SYNCHRONOUS MOTORS

OVERVIEW

Rev. 1.3



IP PROTECTION	IP54 (IP55 on request)
POLES	2p=16
THERMAL PROTECTION TYPE	PT100 (and other on request)
BALANCING, VIBRATION GRADE (EN 60034-14 / VDE 0530 part 14)	A (B on request)
INSULATION CLASS	F
COOLING METHOD	LIQUID (flow rate by size) 10 + 25°C (50 + 77 °F) + GLYCOL 20%
Amb. Cond.	0 + 40°C (32 + 104°F) 1000m ASL
TRANSDUCER	ENCODER OR RESOLVER (on request)
MOUNTING FORM	B3, B35, or other on request
BRAKE	up to 2500 Nm (on request)
DE BEARING	BALL (ROLLER request)
NDE BEARING	BALL (INSULATED)
MAX ABSOLUTE SPEED	1300 r.p.m.
PAINTING SYSTEM	NITRO, POLYURETHANIC, C5M, on request

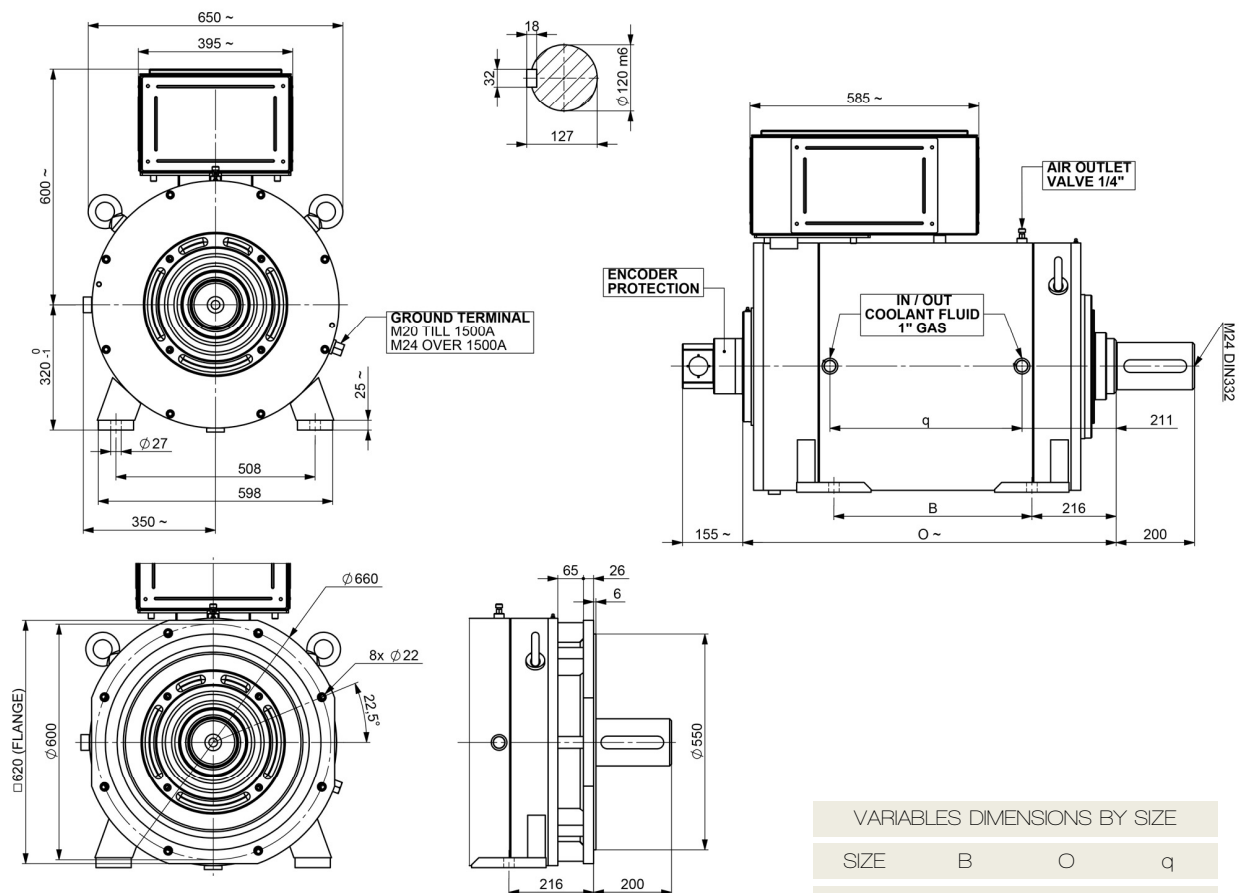

VARIABLES DIMENSIONS BY SIZE			
SIZE	B	O	q
315.32	485	935	470
315.40	565	1015	550
315.48	645	1095	630
315.56	725	1175	710

unit [mm]

400V SUPPLY STANDARD WINDING CODES

Speed Frequency	Type	Rotor Inertia	Max. absolute torque at 400V	Rated torque	Rated power	Rated voltage	Rated current	power factor	Efficiency	Liquid flow rate
rpm Hz		Kgm ²	Nm	Nm	kW	V	A	cosφ	η	L/1'
400 53,3Hz	315.32	8,3	6.500	3.740	157	380	266	0,93	0,96	34
	315.40	9,3	8.000	4.650	195	380	331	0,93	0,96	37
	315.48	10,4	9.500	5.610	235	365	415	0,93	0,96	40
	315.56	11,4	11.500	6.480	271	365	473	0,95	0,96	43
600 80Hz	315.32	8,3	6.500	3.500	220	360	389	0,94	0,96	34
	315.40	9,3	8.000	4.380	275	365	480	0,94	0,97	37
	315.48	10,4	9.500	5.260	330	370	567	0,94	0,97	40
	315.56	11,4	11.500	6.110	383	350	692	0,95	0,97	43
800 106,7Hz	315.32	8,3	6.500	3.210	269	360	477	0,94	0,97	34
	315.40	9,3	8.000	4.020	337	375	573	0,93	0,97	37
	315.48	10,4	9.500	4.820	403	355	717	0,95	0,97	40
	315.56	11,4	11.500	5.610	470	360	819	0,95	0,97	43

All data outputs are referred to power converter clocking frequency (PWM) >4kHz

Other windings on request

POWER DERATING BY INLET LIQUID TEMPERATURE

30°C (86°F) -3,5%

35°C (95°F) -6%

40°C (104°F) -10%

45°C (113°F) -12%

POWERTECH SY12 & SY24 FLUID 400

MEDIUM SPEED SYNCHRONOUS MOTORS

OVERVIEW

Rev. 1.2

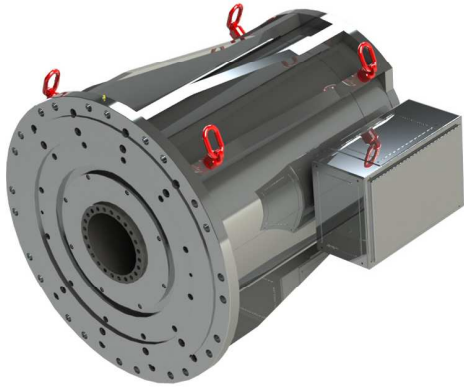

IP PROTECTION	IP54 (IP55 on request)
POLES	SY12 FLUID 400: 2p=12 SY24 FLUID 400: 2p=24
THERMAL PROTECTION TYPE	PT100 (and other on request)
BALANCING, VIBRATION GRADE (EN 60034-14 / VDE 0530 part 14)	A (B on request)
INSULATION CLASS	F
COOLING METHOD	LIQUID (flow rate by size) 10 + 25°C (50 + 77 °F) + GLYCOL 20%
Amb. Cond.	0 + 40°C (32 + 104°F) 1000m ASL
TRANSDUCER	ENCODER OR RESOLVER (on request)
MOUNTING FORM	B3, B35, or other on request
DE BEARING	BALL (ROLLER request)
NDE BEARING	BALL (INSULATED)
MAX ABSOLUTE SPEED	SY12 FLUID 400: 800 r.p.m. SY24 FLUID 400: 500 r.p.m.
PAINTING SYSTEM	NITRO, POLYURETHANIC, C5M, on request

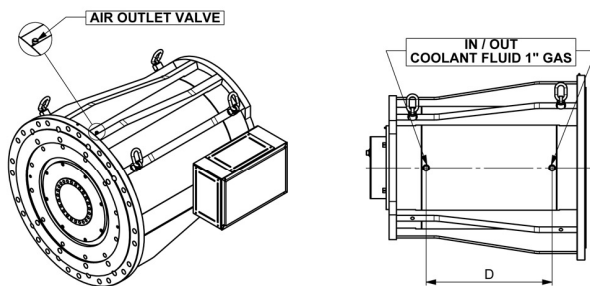
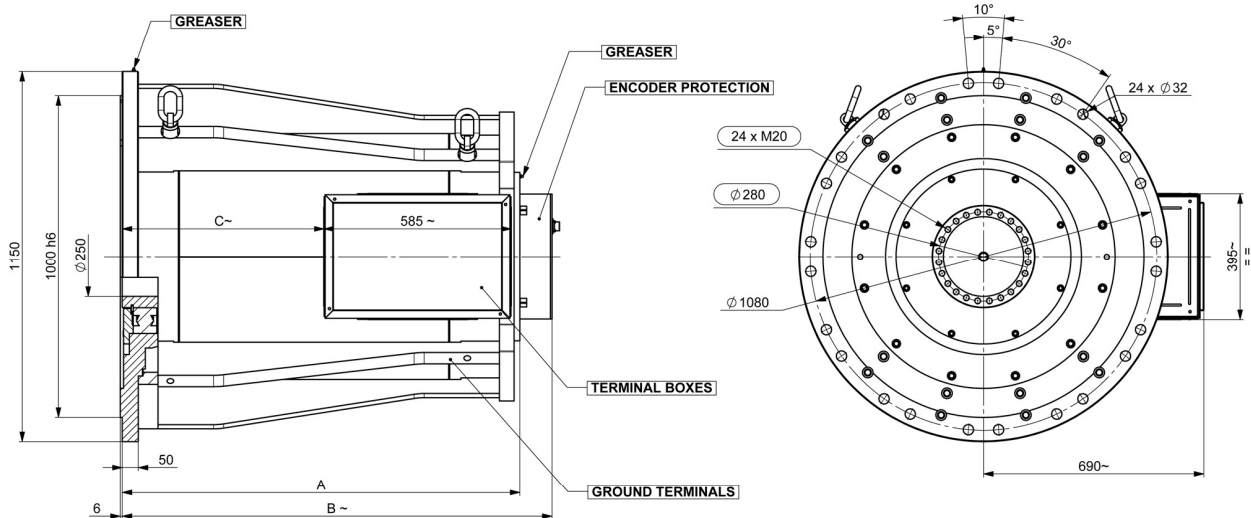

VARIABLES DIMENSIONS BY SIZE				
SIZE	A	B	C	D
400.35	939	1040	330	460
400.45	1039	1140	430	560
400.55	1139	1240	530	660
400.65	1239	1340	630	760
400.75	1339	1440	730	860

unit [mm]

POWERTECH SY12 FLUID 400

Poles 2p=12

400V SUPPLY STANDARD WINDING CODES

Speed Frequency	Type	Rotor Inertia	Max. absolute torque at 400V	Rated torque	Rated power	Rated voltage	Rated current	power factor	Efficiency	Liquid flow rate
rpm Hz		Kgm ²	Nm	Nm	kW	V	A	cos φ	η	L/1'
400 40Hz	400.35	23,9	13.500	7.650	320	340	635	0,90	0,95	68
	400.45	30,4	16.700	9.770	410	355	774	0,91	0,95	72
	400.55	36,9	21.000	11.840	495	360	918	0,90	0,96	76
	400.65	43,4	25.500	14.040	585	350	1.116	0,90	0,96	80
	400.75	50,0	30.500	16.130	675	360	1.242	0,91	0,96	84
600 60Hz	400.35	23,9	13.500	7.290	459	350	882	0,90	0,95	68
	400.45	30,4	16.700	9.320	585	370	1.053	0,91	0,95	72
	400.55	36,9	21.000	11.250	707	345	1.350	0,91	0,96	76
	400.65	43,4	25.500	13.370	837	350	1.575	0,91	0,96	80
	400.75	50,0	30.500	15.320	963	335	1.881	0,92	0,96	84

All data outputs are referred to power converter clocking frequency (PWM) >4kHz

Other windings on request

POWER DERATING BY INLET LIQUID TEMPERATURE

30°C (86°F) -3,5%

35°C (95°F) -6%

40°C (104°F) -10%

45°C (113°F) -12%

POWERTECH SY24 FLUID 400

Poles 2p=24

400V SUPPLY STANDARD WINDING CODES

Speed Frequency	Type	Rotor Inertia	Max. absolute torque at 400V	Rated torque	Rated power	Rated voltage	Rated current	power factor	Efficiency	Liquid flow rate
rpm Hz		Kgm ²	Nm	Nm	kW	V	A	cos φ	η	L/1'
150 30Hz	400.35	23,9	13.500	7.880	123	345	248	0,90	0,93	68
	400.45	30,4	16.700	10.080	158	360	302	0,90	0,93	72
	400.55	36,9	21.000	12.240	194	355	374	0,90	0,94	76
	400.65	43,4	25.500	14.490	225	360	423	0,91	0,94	80
	400.75	50,0	30.500	16.650	261	365	482	0,91	0,94	84
300 60Hz	400.35	23,9	13.500	7.470	234	365	428	0,92	0,94	68
	400.45	30,4	16.700	9.590	302	365	545	0,92	0,95	72
	400.55	36,9	21.000	11.610	365	370	653	0,92	0,95	76
	400.65	43,4	25.500	13.760	432	350	819	0,92	0,95	80
	400.75	50,0	30.500	15.770	495	370	887	0,92	0,95	84

All data outputs are referred to power converter clocking frequency (PWM) >4kHz

Other windings on request

POWER DERATING BY INLET LIQUID TEMPERATURE

30°C (86°F) -3,5%

35°C (95°F) -6%

40°C (104°F) -10%

45°C (113°F) -12%

SYNCHRONOUS PERMANENT MAGNETS MOTORS

RELIABILITY
HIGH POWER
HIGH DYNAMIC
HIGH TORQUE PEAK
SUPER PREMIUM EFFICIENCY (IE4)
EXCELLENT POWER/WEIGHT RATIO
SUITABLE FOR VECTOR DRIVES
IGBT COMPLIANT
WIDE RANGE OF CUSTOMIZATION AND
OPTIONS

TYPICAL APPLICATIONS

FOOD BOXES EXTRUDERS
ENERGY RECOVERY SYSTEMS
LIFTING AND HANDLING SYSTEMS
PLASTIC AND RUBBER EXTRUDERS
PAPER AND CARDBOARD PRODUCTION
MACHINERY
PROCESSING AND CUTTING METAL PLATES
METAL WIRE PROCESSING MACHINERY
PACKAGING MACHINERY
PRINTING MACHINERY
TRACTION CONTROL
MACHINE TOOLS
COMPRESSORS

IP PROTECTION
IP23, IP54 or IP55
COOLING METHOD
IC06, IC416, LIQUID

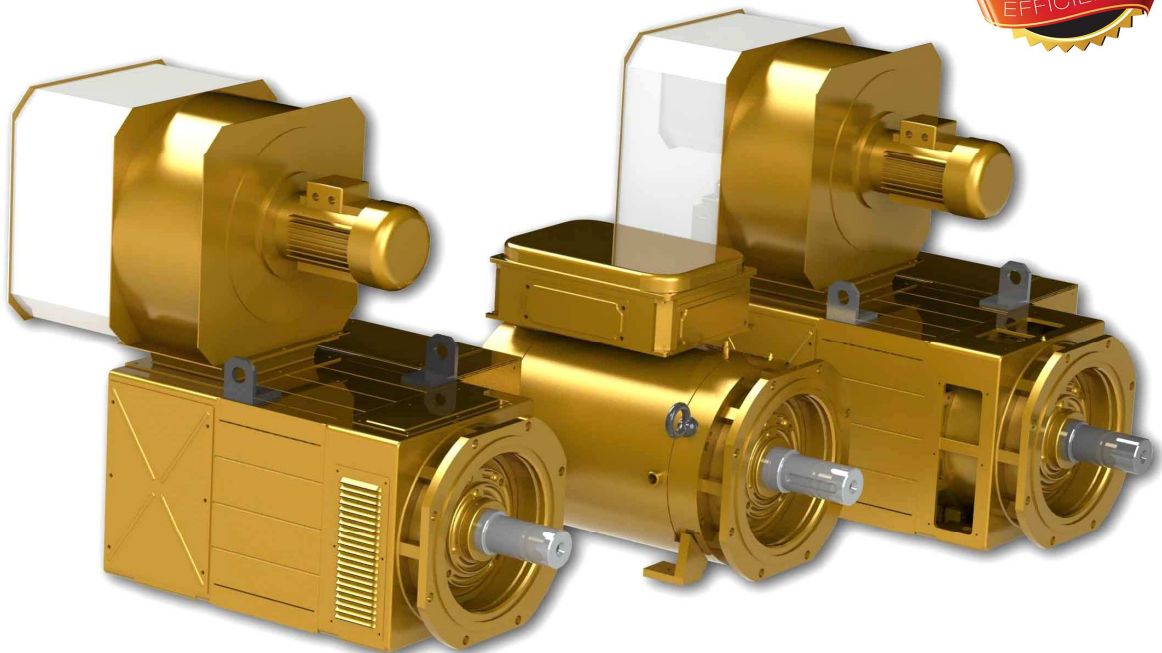

POWERTECH SY4 DRIVE 132K

GENERAL SPEED IE4 SYNCHRONOUS MOTORS

OVERVIEW

Rev. 1.0

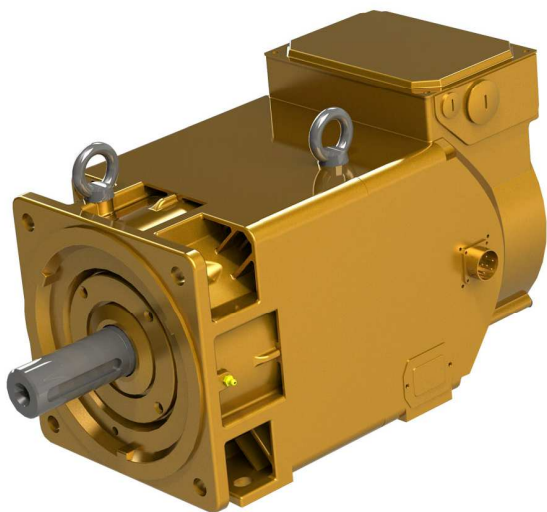

IP PROTECTION	IP54
POLES	2p=4
THERMAL PROTECTION TYPE	PT100 (and other on request)
BALANCING, VIBRATION GRADE (EN 60034-14 / VDE 0530 part 14)	A (B on request)
INSULATION CLASS	F
COOLING METHOD	IC416A
STANDARD FAN DETAILS	3x400Vac 50/60Hz 0,18/0,22A
Amb. Cond.	0 + 40°C (32 + 104°F) 1000m ASL
TRANSDUCER	ENCODER OR RESOLVER (on request)
MOUNTING FORM	B3, B35, or other on request
BRAKE	up to 300 Nm (on request)
DE BEARING	BALL (ROLLER request)
NDE BEARING	BALL
MAX ABSOLUTE SPEED	2700 r.p.m.
PAINTING SYSTEM	NITRO, POLYURETHANIC, C5M, on request

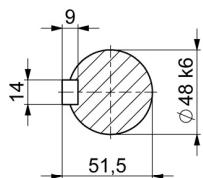
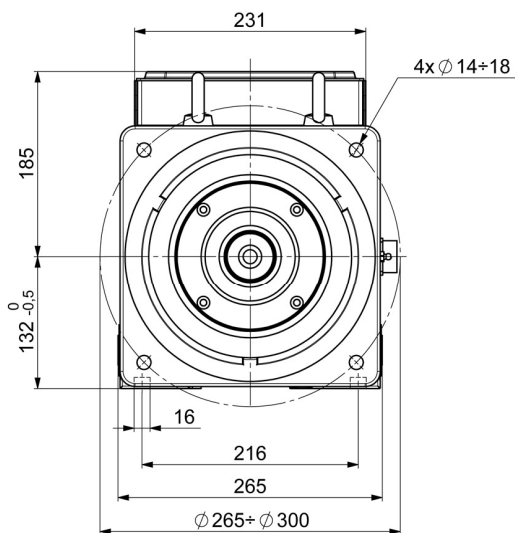
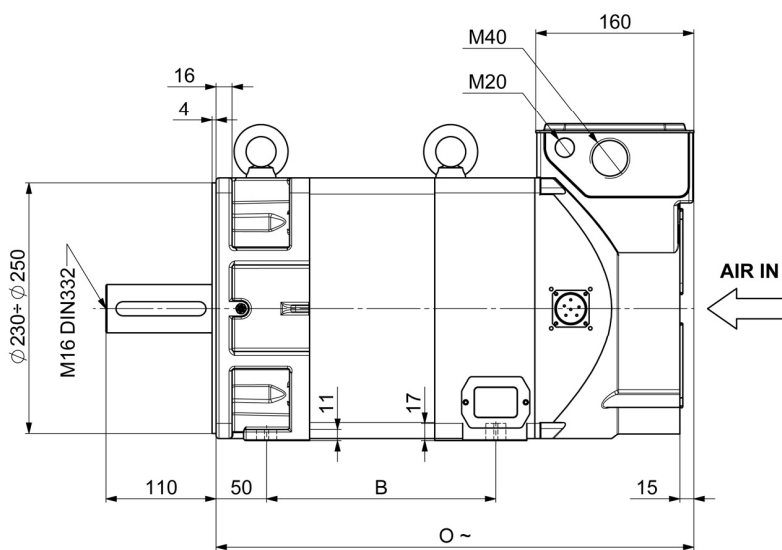

VARIABLES DIMENSIONS BY SIZE

SIZE	B	O
132K.17	272	525
132K.21	307	560
132K.28	377	630
132K.35	447	700

unit [mm]

400V SUPPLY STANDARD WINDING CODES

Speed Frequency	Type	Rotor Inertia	Max. absolute torque at 400V	Rated torque	Rated power	Rated voltage	Rated current	power factor	Efficiency
rpm Hz		Kgm ²	Nm	Nm	kW	V	A	cos ϕ	η
800 26,7Hz	132K.17	0,07	450	123	10,3	340	19	0,99	0,91
	132K.21	0,08	530	145	12,2	350	22	0,99	0,91
	132K.28	0,11	700	190	16,0	335	30	0,99	0,92
	132K.35	0,14	900	240	20,0	350	37	0,97	0,92
1500 50Hz	132K.17	0,07	450	120	19,0	355	34	0,99	0,93
	132K.21	0,08	530	140	22,0	335	41	0,99	0,94
	132K.28	0,11	700	185	29,0	335	54	0,98	0,94
	132K.35	0,14	900	235	37,0	350	65	0,99	0,95
2250 75Hz	132K.17	0,07	450	110	26,0	340	48	0,99	0,94
	132K.21	0,08	530	130	30,7	340	56	0,99	0,95
	132K.28	0,11	700	170	40,0	330	75	0,98	0,95
	132K.35	0,14	900	210	49,5	360	84	0,99	0,95

All data outputs are referred to power converter clocking frequency (PWM) >4kHz

Other windings on request

POWERTECH SY4 DRIVE 160L

GENERAL SPEED IE4 SYNCHRONOUS MOTORS

OVERVIEW

Rev. 1.0



IP PROTECTION	IP54
POLES	2p=4
THERMAL PROTECTION TYPE	PT100 (and other on request)
BALANCING, VIBRATION GRADE (EN 60034-14 / VDE 0530 part 14)	A (B on request)
INSULATION CLASS	F
COOLING METHOD	IC416A
STANDARD FAN DETAILS	3x400Vac 50/60Hz 0,26/0,33A
Amb. Cond.	0 + 40°C (32 + 104°F) 1000m ASL
TRANSDUCER	ENCODER OR RESOLVER (on request)
MOUNTING FORM	B3, B35, or other on request
BRAKE	up to 400 Nm (on request)
DE BEARING	BALL, ROLLER or INSULATED on request
NDE BEARING	BALL (insulated on request)
MAX ABSOLUTE SPEED	2700 r.p.m.
PAINTING SYSTEM	NITRO, POLYURETHANIC, C5M, on request

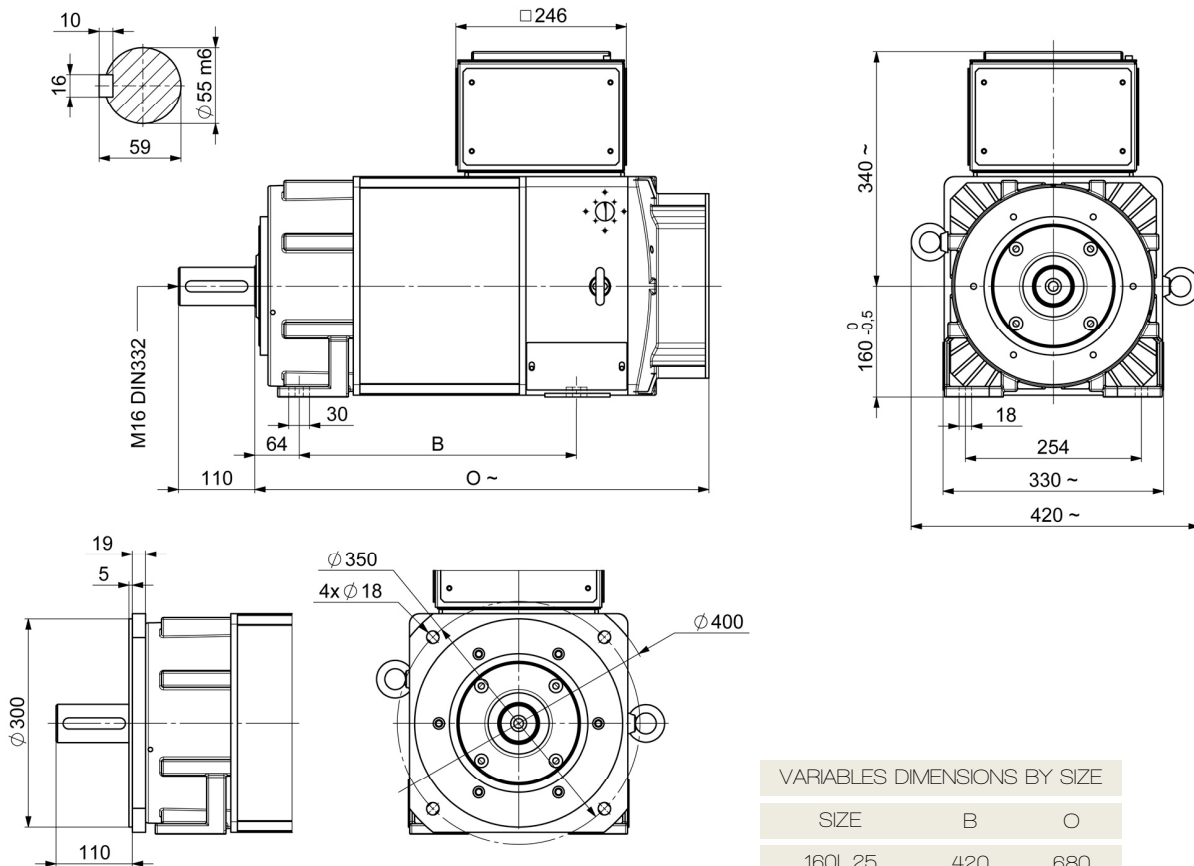

VARIABLES DIMENSIONS BY SIZE		
SIZE	B	O
160L.25	420	680
160L.30	470	730
160L.35	520	780
160L.40	570	830
160L.45	620	880

unit [mm]

400V SUPPLY STANDARD WINDING CODES

Speed Frequency	Type	Rotor Inertia	Max. absolute torque at 400V	Rated torque	Rated power	Rated voltage	Rated current	power factor	Efficiency
rpm Hz		Kgm ²	Nm	Nm	kW	V	A	cosφ	η
800 26,7Hz	160L.25	0,20	550	290	24,3	370	44	0,93	0,93
	160L.30	0,24	700	350	29,3	360	55	0,93	0,93
	160L.35	0,28	830	400	33,6	350	65	0,91	0,93
	160L.40	0,32	950	460	38,5	335	76	0,93	0,94
	160L.45	0,35	1.100	525	44,0	350	83	0,93	0,94
1500 50Hz	160L.25	0,20	550	275	43,2	350	80	0,94	0,95
	160L.30	0,24	700	330	51,8	345	98	0,93	0,95
	160L.35	0,28	830	380	60,0	360	109	0,93	0,95
	160L.40	0,32	950	435	68,3	355	124	0,94	0,96
	160L.45	0,35	1.100	490	77,0	345	145	0,93	0,96
2250 75Hz	160L.25	0,20	550	230	54,2	330	106	0,94	0,95
	160L.30	0,24	700	270	64,0	340	123	0,93	0,96
	160L.35	0,28	830	315	74,2	325	146	0,94	0,96
	160L.40	0,32	950	355	83,6	370	143	0,95	0,96
	160L.45	0,35	1.100	400	94,0	335	178	0,95	0,96

All data outputs are referred to power converter clocking frequency (PWM) >4kHz

Other windings on request

POWERTECH SY6 DRIVE 200L

GENERAL SPEED IE4 SYNCHRONOUS MOTORS

OVERVIEW

Rev. 1.0



IP PROTECTION	IP54
POLES	2p=6
THERMAL PROTECTION TYPE	PT100 (and other on request)
BALANCING, VIBRATION GRADE (EN 60034-14 / VDE 0530 part 14)	A (B on request)
INSULATION CLASS	F
COOLING METHOD	IC416A
STANDARD FAN DETAILS	3x400Vac 50/60Hz 0,43/0,58A
Amb. Cond.	0 + 40°C (32 + 104°F) 1000m ASL
TRANSDUCER	ENCODER OR RESOLVER (on request)
MOUNTING FORM	B3, B35, or other on request
BRAKE	up to 600 Nm (on request)
DE BEARING	BALL, ROLLER or INSULATED on request
NDE BEARING	BALL (insulated on request)
MAX ABSOLUTE SPEED	2500 r.p.m.
PAINTING SYSTEM	NITRO, POLYURETHANIC, C5M, on request

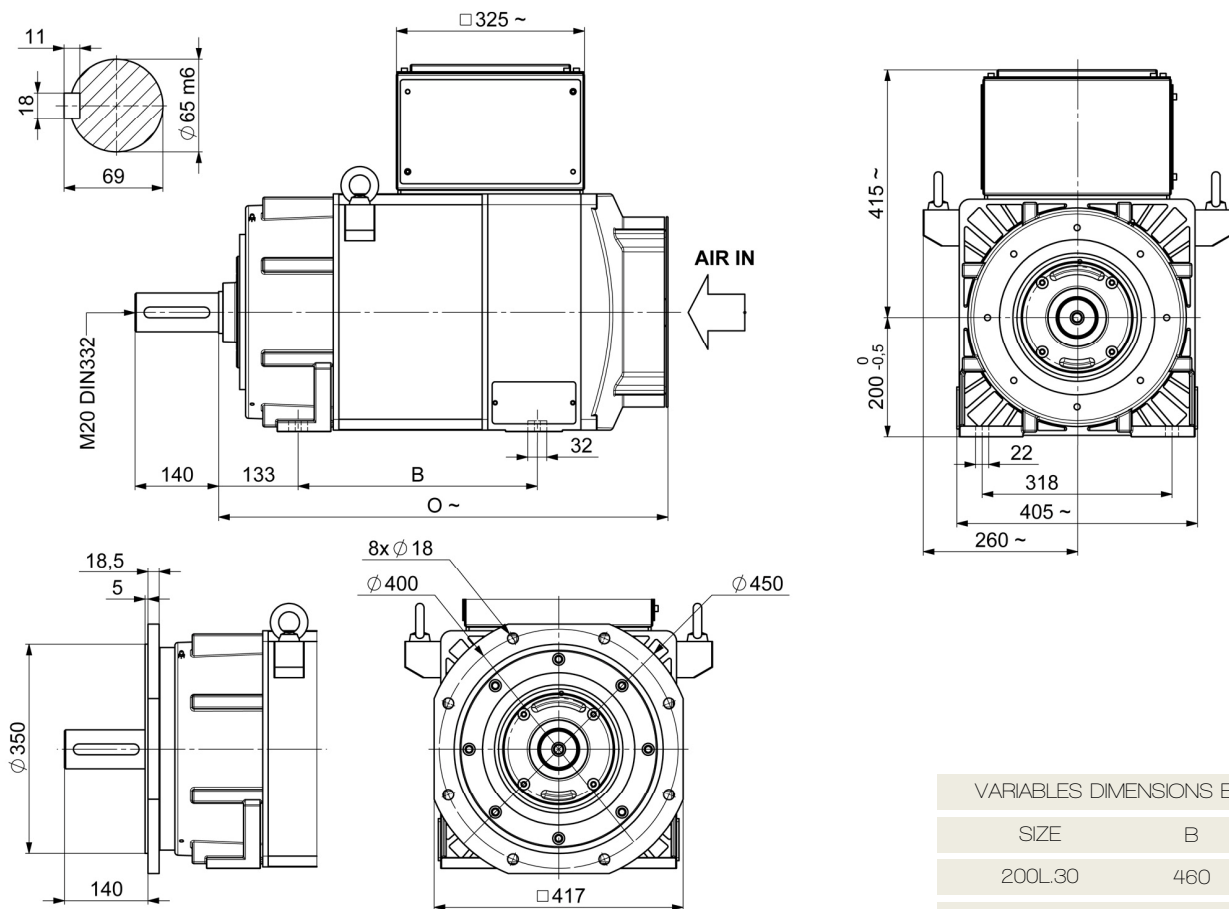

VARIABLES DIMENSIONS BY SIZE		
SIZE	B	O
200L.30	460	820
200L.35	510	870
200L.40	560	920
200L.50	660	1020
200L.55	710	1070

unit [mm]

400V SUPPLY STANDARD WINDING CODES

Speed Frequency	Type	Rotor Inertia	Max. absolute torque at 400V	Rated torque	Rated power	Rated voltage	Rated current	power factor	Efficiency
rpm Hz		Kgm ²	Nm	Nm	kW	V	A	cosφ	η
700 35Hz	200L.30	0,68	1.500	545	40	375	68	0,96	0,95
	200L.35	0,81	1.800	630	46	365	80	0,96	0,95
	200L.40	0,93	2.100	700	51	345	95	0,94	0,95
	200L.50	1,15	2.700	845	62	340	115	0,96	0,96
	200L.55	1,27	3.000	915	67	335	125	0,97	0,96
1400 70Hz	200L.30	0,68	1.500	530	78	365	133	0,96	0,96
	200L.35	0,81	1.800	575	84	380	138	0,96	0,96
	200L.40	0,93	2.100	680	100	340	185	0,95	0,96
	200L.50	1,15	2.700	805	118	360	202	0,97	0,97
	200L.55	1,58	3.000	850	125	330	235	0,96	0,97
2000 100Hz	200L.30	0,68	1.500	500	105	360	180	0,97	0,96
	200L.35	0,81	1.800	575	120	360	208	0,96	0,97
	200L.40	0,93	2.100	645	135	340	245	0,97	0,97
	200L.50	1,15	2.700	750	157	340	284	0,97	0,97
	200L.55	1,58	3.000	800	167	370	275	0,98	0,97

All data outputs are referred to power converter clocking frequency (PWM) >4kHz

Other windings on request

POWERTECH SY6 DRIVE 250K

GENERAL SPEED IE4 SYNCHRONOUS MOTORS

OVERVIEW

Rev. 1.0

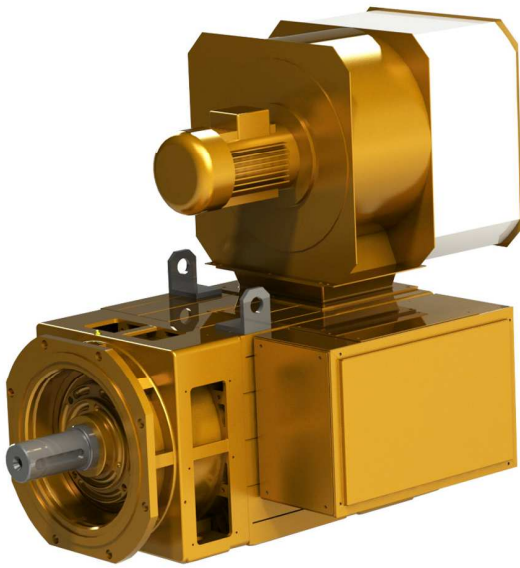

IP PROTECTION	IP54
POLES	2p=6
THERMAL PROTECTION TYPE	PT100 (and other on request)
BALANCING, VIBRATION GRADE (EN 60034-14 / VDE 0530 part 14)	A (B on request)
INSULATION CLASS	F
COOLING METHOD	IC416R (with filter on request)
STANDARD FAN DETAILS	3x230/400Vac 50Hz 11,5/6,6A
Amb. Cond.	0 + 40°C (32 + 104°F) 1000m ASL
TRANSDUCER	ENCODER OR RESOLVER (on request)
MOUNTING FORM	B3, B35, or other on request
BRAKE	up to 2400 Nm (on request)
DE BEARING	BALL (ROLLER on request)
NDE BEARING	BALL (insulated on request)
MAX ABSOLUTE SPEED	2300 r.p.m.
PAINTING SYSTEM	NITRO, POLYURETHANIC, C5M, on request

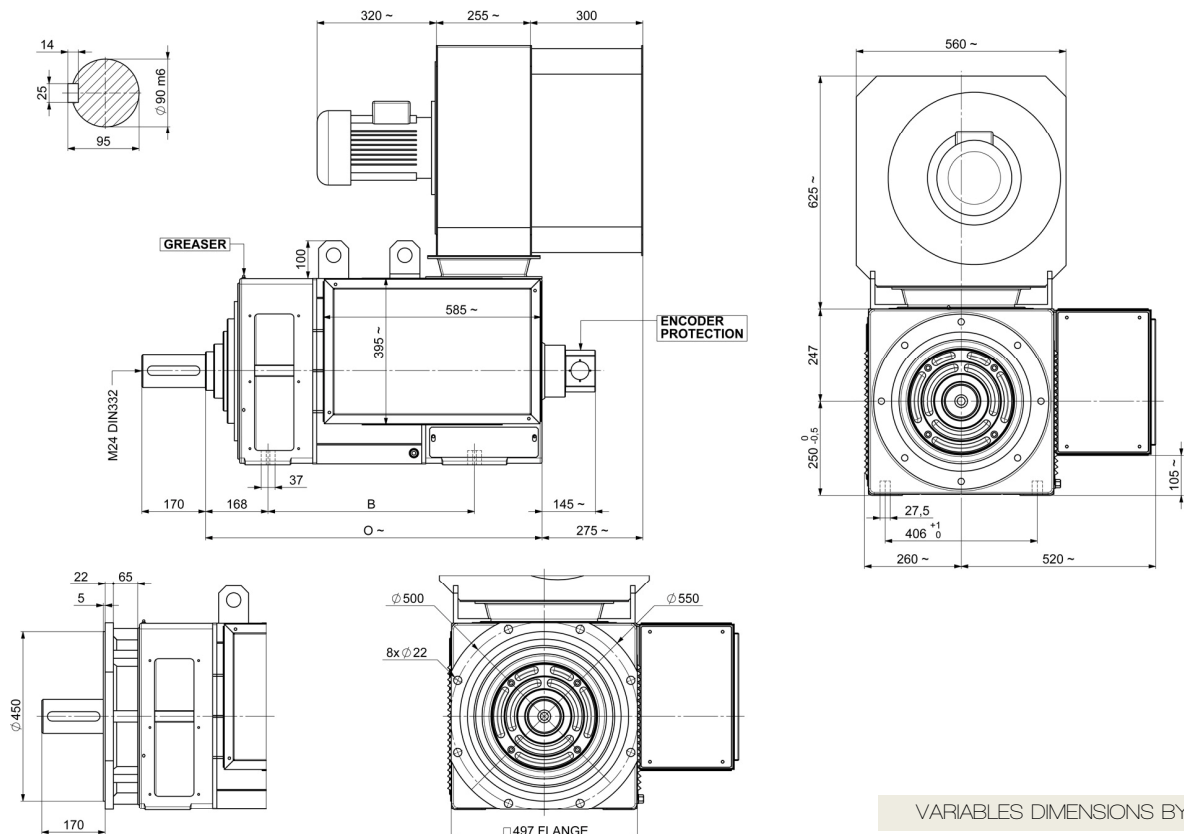

VARIABLES DIMENSIONS BY SIZE		
SIZE	B	O
250K.30	571	920
250K.40	671	1020
250K.50	771	1120
250K.60	871	1220
250K.70	971	1320

unit [mm]

400V SUPPLY STANDARD WINDING CODES

Speed Frequency	Type	Rotor Inertia	Max. absolute torque at 400V	Rated torque	Rated power	Rated voltage	Rated current	power factor	Efficiency
rpm Hz		Kgm ²	Nm	Nm	kW	V	A	cosφ	η
700 35Hz	250K.30	1,9	2.900	1.150	84	375	145	0,93	0,96
	250K.40	2,5	3.800	1.500	110	360	195	0,94	0,96
	250K.50	3,1	4.800	1.800	132	335	245	0,96	0,96
	250K.60	3,8	5.700	2.130	156	365	265	0,96	0,97
	250K.70	4,4	6.700	2.460	180	355	320	0,95	0,97
1400 70Hz	250K.30	1,9	2.900	1.070	157	370	270	0,94	0,97
	250K.40	2,5	3.800	1.400	205	355	360	0,96	0,97
	250K.50	3,1	4.800	1.710	250	355	435	0,96	0,97
	250K.60	3,8	5.700	2.010	295	360	505	0,97	0,97
	250K.70	4,4	6.700	2.350	345	385	555	0,96	0,97
2000 100Hz	250K.30	1,9	2.900	1.000	210	375	350	0,96	0,96
	250K.40	2,5	3.800	1.300	272	380	450	0,95	0,97
	250K.50	3,1	4.800	1.620	340	350	600	0,97	0,97
	250K.60	3,8	5.700	1.920	402	375	665	0,96	0,97
	250K.70	4,4	6.700	2.200	460	385	745	0,96	0,97

All data outputs are referred to power converter clocking frequency (PWM) >4kHz

Also available in Axial Fan Version (IC416A)

POWER DERATING -10%

Other windings on request

POWERTECH SY6 DRIVE 315L

GENERAL SPEED IE4 SYNCHRONOUS MOTORS

OVERVIEW

Rev. 1.1

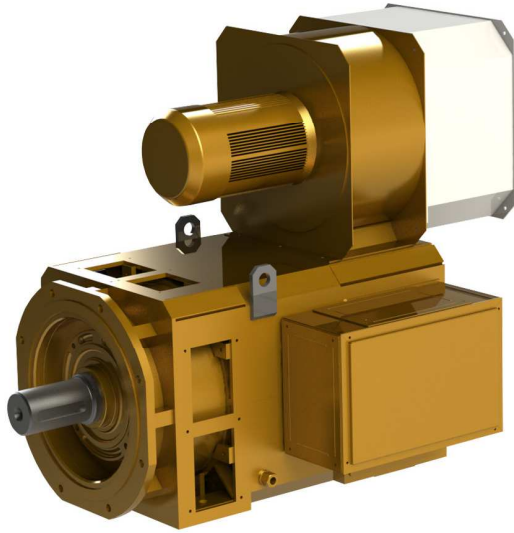

IP PROTECTION	IP54
POLES	2p=6
THERMAL PROTECTION TYPE	PT100 (and other on request)
BALANCING, VIBRATION GRADE (EN 60034-14 / VDE 0530 part 14)	A (B on request)
INSULATION CLASS	F
COOLING METHOD	IC416R (with filter on request)
STANDARD FAN DETAILS	3x230/400Vac 50Hz 19,6/11,3A
Amb. Cond.	0 + 40°C (32 + 104°F) 1000m ASL
TRANSDUCER	ENCODER OR RESOLVER (on request)
MOUNTING FORM	B3, B35, or other on request
BRAKE	up to 2500 Nm (on request)
DE BEARING	BALL (ROLLER on request)
NDE BEARING	BALL (INSULATED)
MAX ABSOLUTE SPEED	1800 r.p.m.
PAINTING SYSTEM	NITRO, POLYURETHANIC, C5M, on request

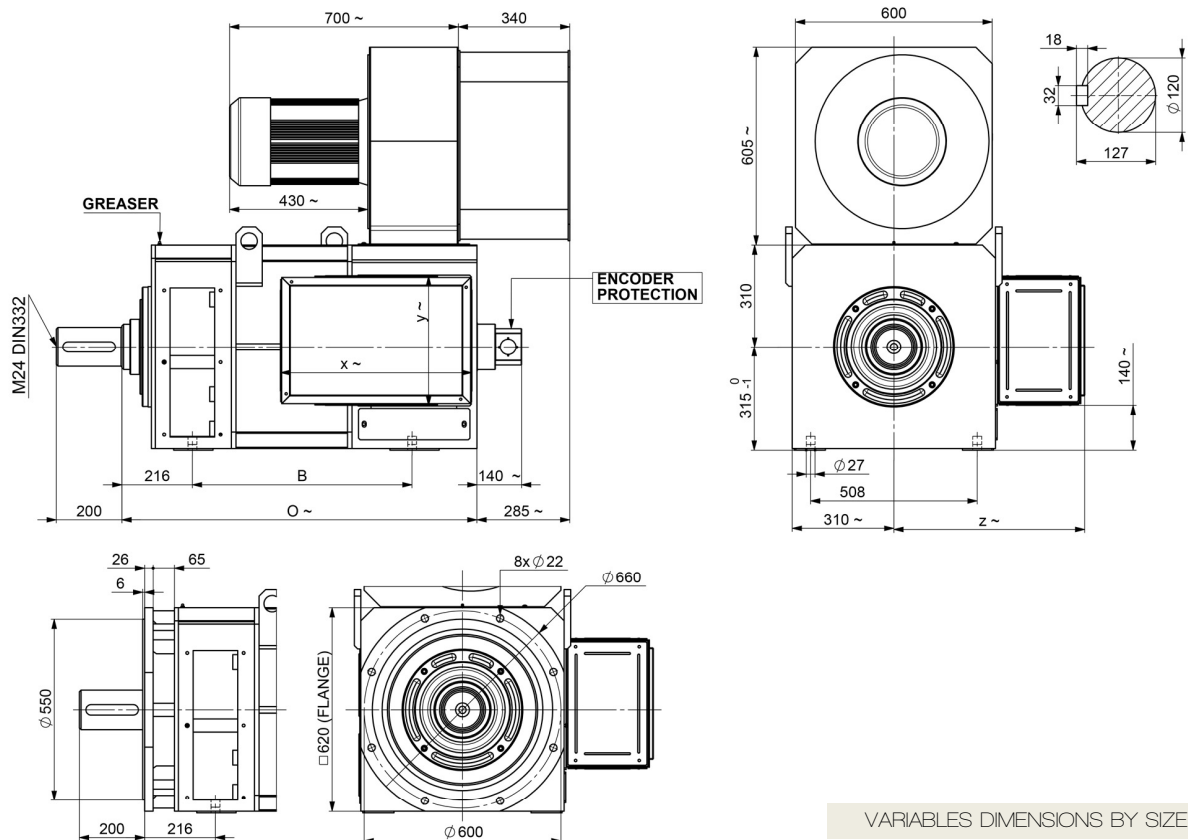

TERMINAL BOX DIMENSIONS			
TYPE	x	x	z
STANDARD	585	400	585
INCREASED (on request)	645	534	585

VARIABLES DIMENSIONS BY SIZE		
SIZE	B	O
315L.40	730	1150
315L.50	830	1250
315L.60	930	1350
315L.70	1030	1450
315L.80	1130	1550

unit [mm]

400V SUPPLY STANDARD WINDING CODES

Speed Frequency	Type	Rotor Inertia	Max. absolute torque at 400V	Rated torque	Rated power	Rated voltage	Rated current	power factor	Efficiency
rpm Hz		Kgm ²	Nm	Nm	kW	V	A	cosφ	η
500 25Hz	315L.40	6,6	6.200	2.680	140	370	250	0,91	0,96
	315L.50	8,2	7.600	3.300	173	360	315	0,92	0,96
	315L.60	9,9	9.500	3.960	207	365	365	0,93	0,96
	315L.70	11,5	11.000	4.620	242	360	435	0,92	0,97
	315L.80	13,2	12.500	5.250	275	365	480	0,94	0,97
1000 50Hz	315L.40	6,6	6.200	2.530	265	370	470	0,91	0,97
	315L.50	8,2	7.600	3.150	330	380	560	0,92	0,97
	315L.60	9,9	9.500	3.820	400	365	705	0,92	0,97
	315L.70	11,5	11.000	4.400	460	350	835	0,93	0,97
	315L.80	13,2	12.500	5.000	525	360	925	0,93	0,98
1500 75Hz	315L.40	6,6	6.200	2.450	385	365	680	0,92	0,97
	315L.50	8,2	7.600	3.050	480	370	815	0,94	0,97
	315L.60	9,9	9.500	3.600	565	360	1.000	0,93	0,97
	315L.70	11,5	11.000	4.200	660	360	1.140	0,95	0,97
	315L.80	13,2	12.500	4.800	750	350	1.330	0,96	0,97

All data outputs are referred to power converter clocking frequency (PWM) >4kHz

Also available in Axial Fan Version (IC416A)

POWER DERATING -10%

Other windings on request

POWERTECH SY4 TETRAVEC 132K

GENERAL SPEED IE4 SYNCHRONOUS MOTORS

OVERVIEW

Rev. 1.0

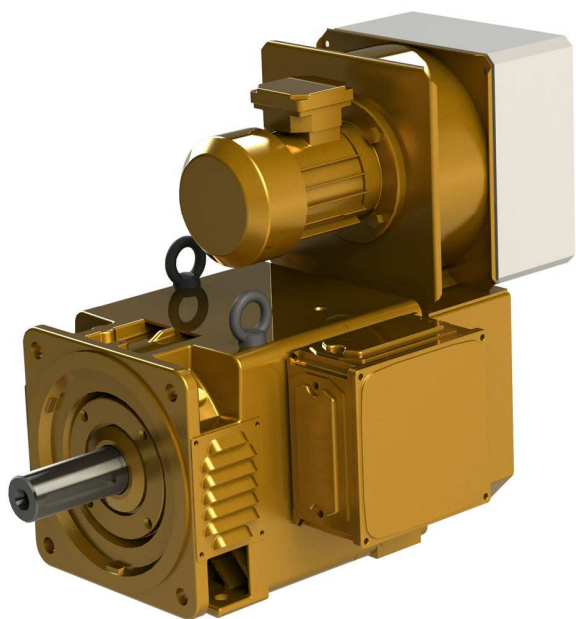

IP PROTECTION	IP23
POLES	2p=4
THERMAL PROTECTION TYPE	PT100 (and other on request)
BALANCING, VIBRATION GRADE (EN 60034-14 / VDE 0530 part 14)	A (B on request)
INSULATION CLASS	F
COOLING METHOD	IC06 (with filter on request)
STANDARD FAN DETAILS	3x230/400Vac 50Hz 1,9/1,1A
Amb. Cond.	0 + 40°C (32 + 104°F) 1000m ASL
TRANSDUCER	ENCODER OR RESOLVER (on request)
MOUNTING FORM	B3, B35, or other on request
BRAKE	up to 300 Nm (on request)
DE BEARING	BALL (ROLLER on request)
NDE BEARING	BALL
MAX ABSOLUTE SPEED	2700 r.p.m.
PAINTING SYSTEM	NITRO, POLYURETHANIC, C5M, on request

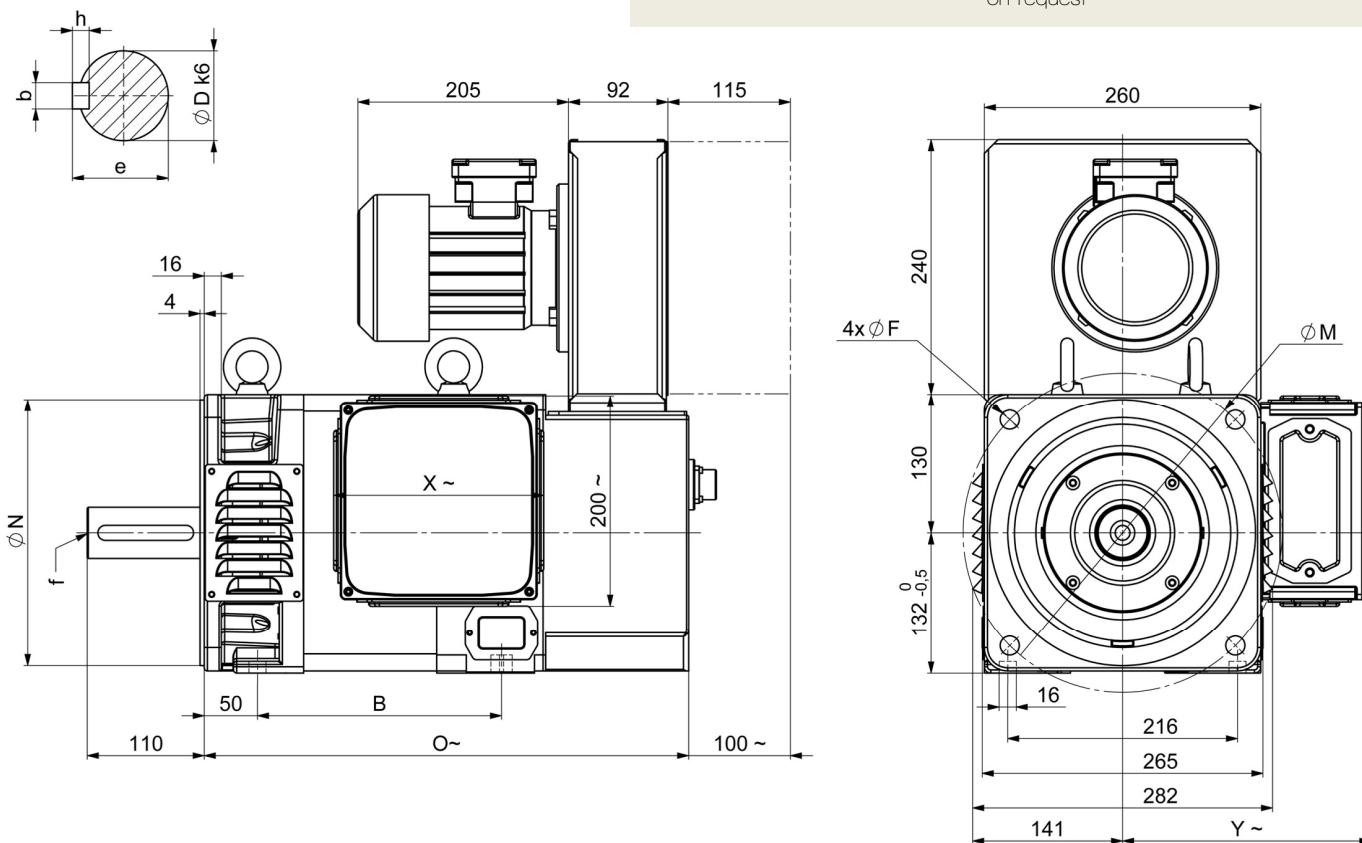

VARIABLES DIMENSIONS BY SIZE

SIZE	B	O
132K.17	272	505
132K.21	307	540
132K.28	377	610
132K.35	447	680

FLANGE

M	N	F
265	230	14
300	250	18

SHAFT AND KEYWAY

D	bxh	e	f
48	14x9	51,5	M16

unit [mm]

400V SUPPLY STANDARD WINDING CODES

Speed Frequency	Type	Rotor Inertia	Max. absolute torque at 400V	Rated torque	Rated power	Rated voltage	Rated current	power factor	Efficiency
rpm Hz		Kgm ²	Nm	Nm	kW	V	A	cos ϕ	η
800 26,7Hz	132K.17	0,07	450	180	15,0	370	28	0,97	0,87
	132K.21	0,08	530	215	18,0	365	33	0,98	0,87
	132K.28	0,11	700	300	25,0	360	45	0,99	0,89
	132K.35	0,14	900	360	30,0	360	55	0,98	0,90
1500 50Hz	132K.17	0,07	450	180	28,3	370	50	0,97	0,92
	132K.21	0,08	530	215	33,8	350	62	0,97	0,92
	132K.28	0,11	700	285	44,8	345	82	0,98	0,93
	132K.35	0,14	900	350	55,0	360	97	0,98	0,94
2250 75Hz	132K.17	0,07	450	175	41,3	350	75	0,98	0,93
	132K.21	0,08	530	205	48,3	350	87	0,98	0,94
	132K.28	0,11	700	275	65,0	340	120	0,98	0,94
	132K.35	0,14	900	335	79,0	375	133	0,97	0,95

All data outputs are referred to power converter clocking frequency (PWM) >4kHz

Other windings on request

POWERTECH SY4 TETRAVEC 160L

GENERAL SPEED IE4 SYNCHRONOUS MOTORS

OVERVIEW

Rev. 1.1

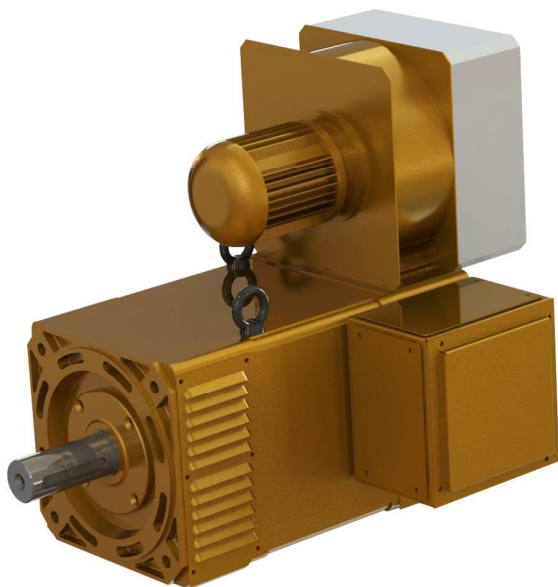

IP PROTECTION	IP23
POLES	2p=4
THERMAL PROTECTION TYPE	PT100 (and other on request)
BALANCING, VIBRATION GRADE (EN 60034-14 / VDE 0530 part 14)	A (B on request)
INSULATION CLASS	F
COOLING METHOD	IC06 (with filter on request)
STANDARD FAN DETAILS	3x230/400Vac 50Hz 4,5/2,6A
Amb. Cond.	0 + 40°C (32 + 104°F) 1000m ASL
TRANSDUCER	ENCODER OR RESOLVER (on request)
MOUNTING FORM	B3, B35, or other on request
BRAKE	up to 400 Nm (on request)
DE BEARING	BALL (ROLLER on request)
NDE BEARING	BALL (insulated on request)
MAX ABSOLUTE SPEED	2700 r.p.m.
PAINTING SYSTEM	NITRO, POLYURETHANIC, C5M, on request

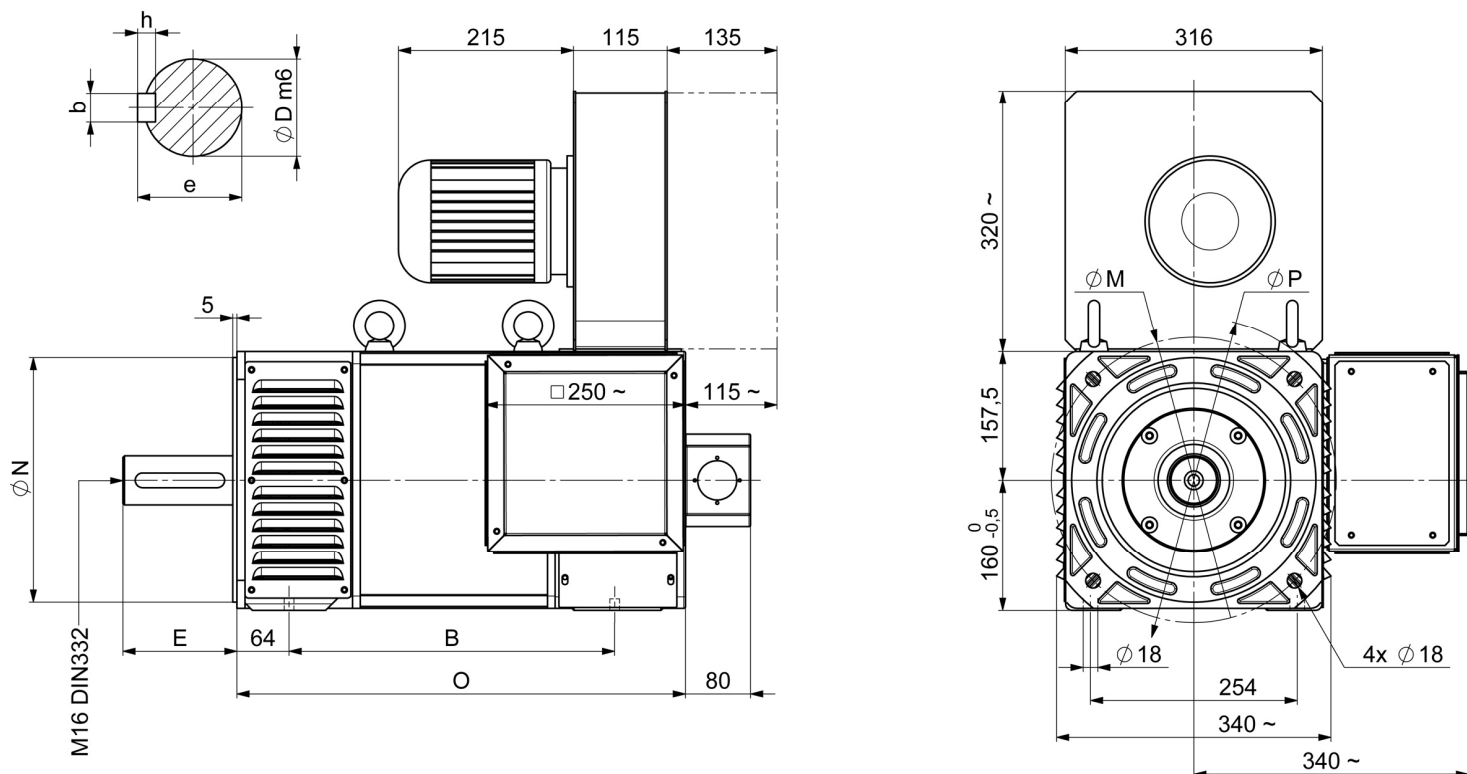

VARIABLES DIMENSIONS BY SIZE

SIZE	B	O
160L.25	420	571
160L.30	470	621
160L.35	520	671
160L.40	570	721
160L.45	620	771

FLANGE

P	M	N
400	300	250
400	350	300

SHAFT AND KEYWAY

DxE	bxh	e
60x140	18x11	64

unit [mm]

400V SUPPLY STANDARD WINDING CODES

Speed Frequency	Type	Rotor Inertia	Max. absolute torque at 400V	Rated torque	Rated power	Rated voltage	Rated current	power factor	Efficiency
rpm Hz		Kgm ²	Nm	Nm	kW	V	A	cosφ	η
800 26,7Hz	160L.25	0,20	550	425	35,6	385	68	0,87	0,90
	160L.30	0,24	700	500	42,0	385	78	0,89	0,91
	160L.35	0,28	830	560	46,0	365	90	0,88	0,92
	160L.40	0,32	950	625	52,4	355	104	0,89	0,92
	160L.45	0,35	1.100	680	57,0	370	109	0,88	0,93
1500 50Hz	160L.25	0,20	550	420	66,0	380	122	0,88	0,94
	160L.30	0,24	700	490	77,0	370	145	0,88	0,95
	160L.35	0,28	830	550	86,3	380	156	0,89	0,95
	160L.40	0,32	950	610	96,0	375	174	0,90	0,95
	160L.45	0,35	1.100	660	104	365	195	0,89	0,95
2250 75Hz	160L.25	0,20	550	400	94,2	350	184	0,89	0,95
	160L.30	0,24	700	460	108	360	205	0,89	0,95
	160L.35	0,28	830	515	121	350	235	0,89	0,96
	160L.40	0,32	950	570	135	390	229	0,91	0,96
	160L.45	0,35	1.100	625	147	355	276	0,91	0,96

All data outputs are referred to power converter clocking frequency (PWM) >4kHz

Other windings on request

POWERTECH SY6 TETRAVEC 200L

GENERAL SPEED IE4 SYNCHRONOUS MOTORS

OVERVIEW

Rev. 1.0

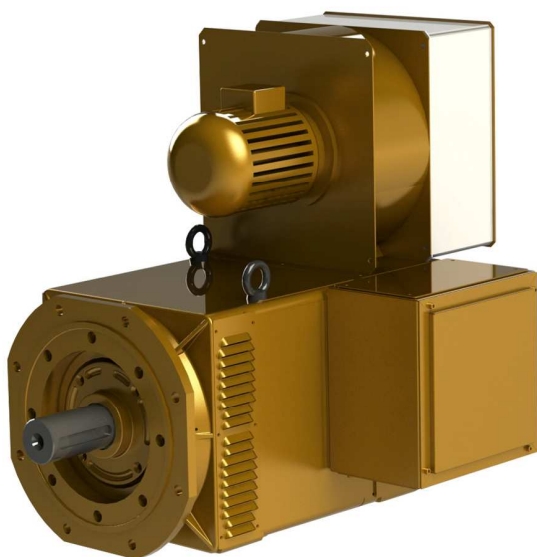

IP PROTECTION	IP23
POLES	2p=6
THERMAL PROTECTION TYPE	PT100 (and other on request)
BALANCING, VIBRATION GRADE (EN 60034-14 / VDE 0530 part 14)	A (B on request)
INSULATION CLASS	F
COOLING METHOD	IC06 (with filter on request)
STANDARD FAN DETAILS	3x230/400Vac 50Hz 5,7/3,3A
Amb. Cond.	0 + 40°C (32 + 104°F) 1000m ASL
TRANSDUCER	ENCODER OR RESOLVER (on request)
MOUNTING FORM	B3, B35, or other on request
BRAKE	up to 600 Nm (on request)
DE BEARING	BALL (ROLLER on request)
NDE BEARING	BALL (insulated on request)
MAX ABSOLUTE SPEED	2500 r.p.m.
PAINTING SYSTEM	NITRO, POLYURETHANIC, C5M, on request

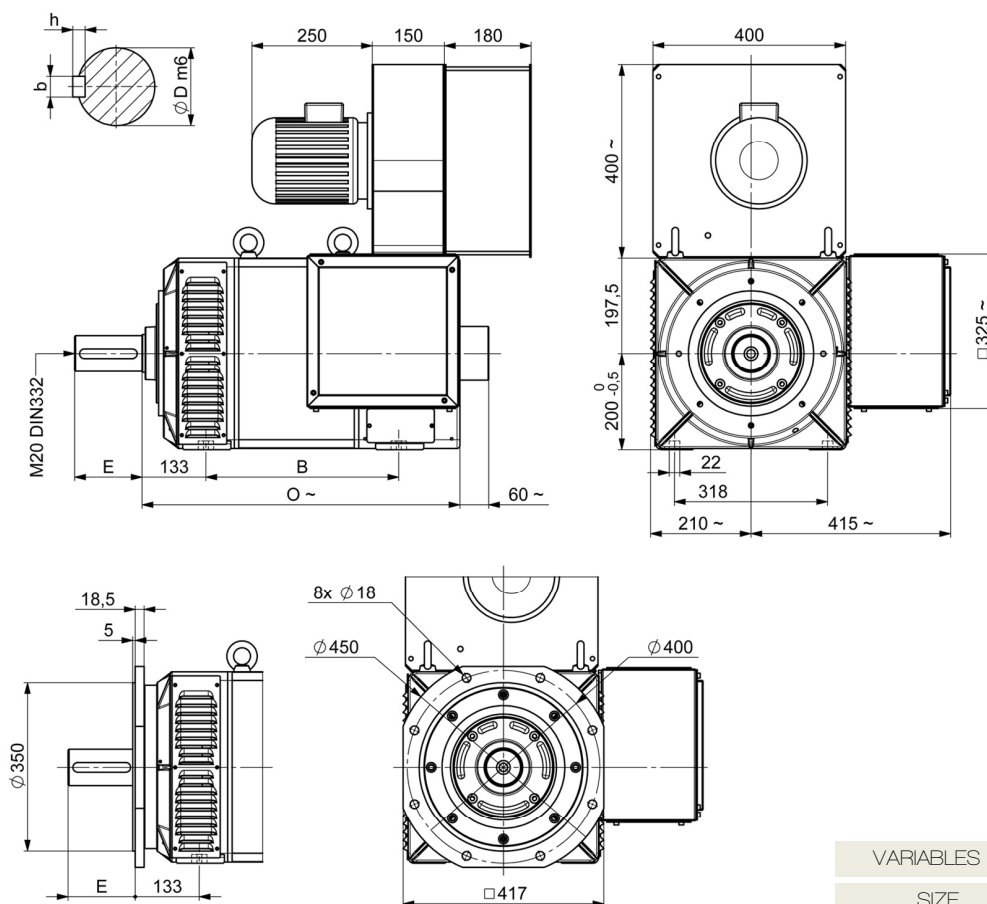

SHAFT AND KEYWAY	
DxE	b x h
75x140	20x12

unit [mm]

VARIABLES DIMENSIONS BY SIZE		
SIZE	B	O
200L.30	460	720
200L.35	510	770
200L.40	560	820
200L.50	660	920
200L.55	710	970

400V SUPPLY STANDARD WINDING CODES

Speed Frequency	Type	Rotor Inertia	Max. absolute torque at 400V	Rated torque	Rated power	Rated voltage	Rated current	power factor	Efficiency
rpm Hz		Kgm ²	Nm	Nm	kW	V	A	cosφ	η
700 35Hz	200L.30	0,68	1.500	930	68	360	130	0,91	0,92
	200L.35	0,81	1.800	1.080	79	375	145	0,91	0,93
	200L.40	0,93	2.100	1.200	88	375	161	0,91	0,93
	200L.50	1,15	2.700	1.470	108	360	200	0,93	0,94
	200L.55	1,27	3.000	1.580	116	360	215	0,92	0,94
1400 70Hz	200L.30	0,68	1.500	900	132	385	225	0,92	0,95
	200L.35	0,81	1.800	1.050	154	365	282	0,91	0,95
	200L.40	0,93	2.100	1.180	173	360	318	0,91	0,96
	200L.50	1,15	2.700	1.440	211	385	360	0,92	0,96
	200L.55	1,58	3.000	1.570	230	350	430	0,92	0,96
2000 100Hz	200L.30	0,68	1.500	860	180	380	308	0,92	0,96
	200L.35	0,81	1.800	1.000	210	385	357	0,92	0,96
	200L.40	0,93	2.100	1.140	238	365	427	0,91	0,96
	200L.50	1,15	2.700	1.390	291	360	522	0,93	0,97
	200L.55	1,58	3.000	1.500	315	390	515	0,94	0,97

All data outputs are referred to power converter clocking frequency (PWM) >4kHz

Other windings on request

POWERTECH SY6 TETRAVEC 250K

GENERAL SPEED IE4 SYNCHRONOUS MOTORS

OVERVIEW

Rev. 1.0

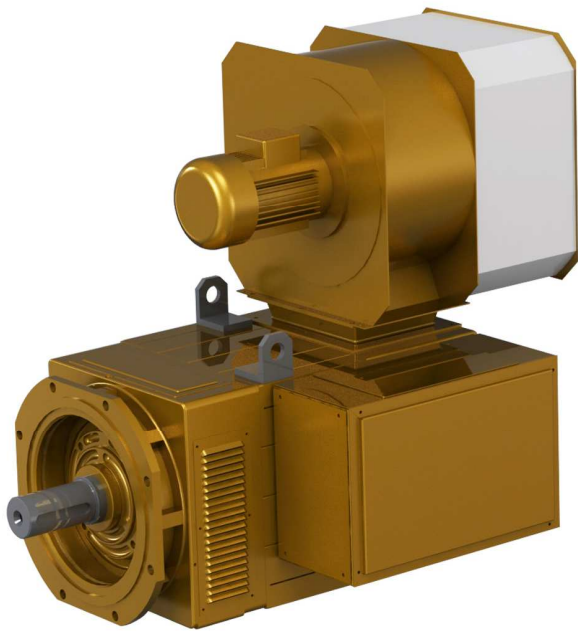

IP PROTECTION	IP23
POLES	2p=6
THERMAL PROTECTION TYPE	PT100 (and other on request)
BALANCING, VIBRATION GRADE (EN 60034-14 / VDE 0530 part 14)	A (B on request)
INSULATION CLASS	F
COOLING METHOD	IC06 (with filter on request)
STANDARD FAN DETAILS	3x230/400Vac 50Hz 11,5/6,6A
Amb. Cond.	0 + 40°C (32 + 104°F) 1000m ASL
TRANSDUCER	ENCODER OR RESOLVER (on request)
MOUNTING FORM	B3, B35, or other on request
BRAKE	up to 2400 Nm (on request)
DE BEARING	BALL (ROLLER on request)
NDE BEARING	BALL (insulated on request)
MAX ABSOLUTE SPEED	2300 r.p.m.
PAINTING SYSTEM	NITRO, POLYURETHANIC, C5M, on request

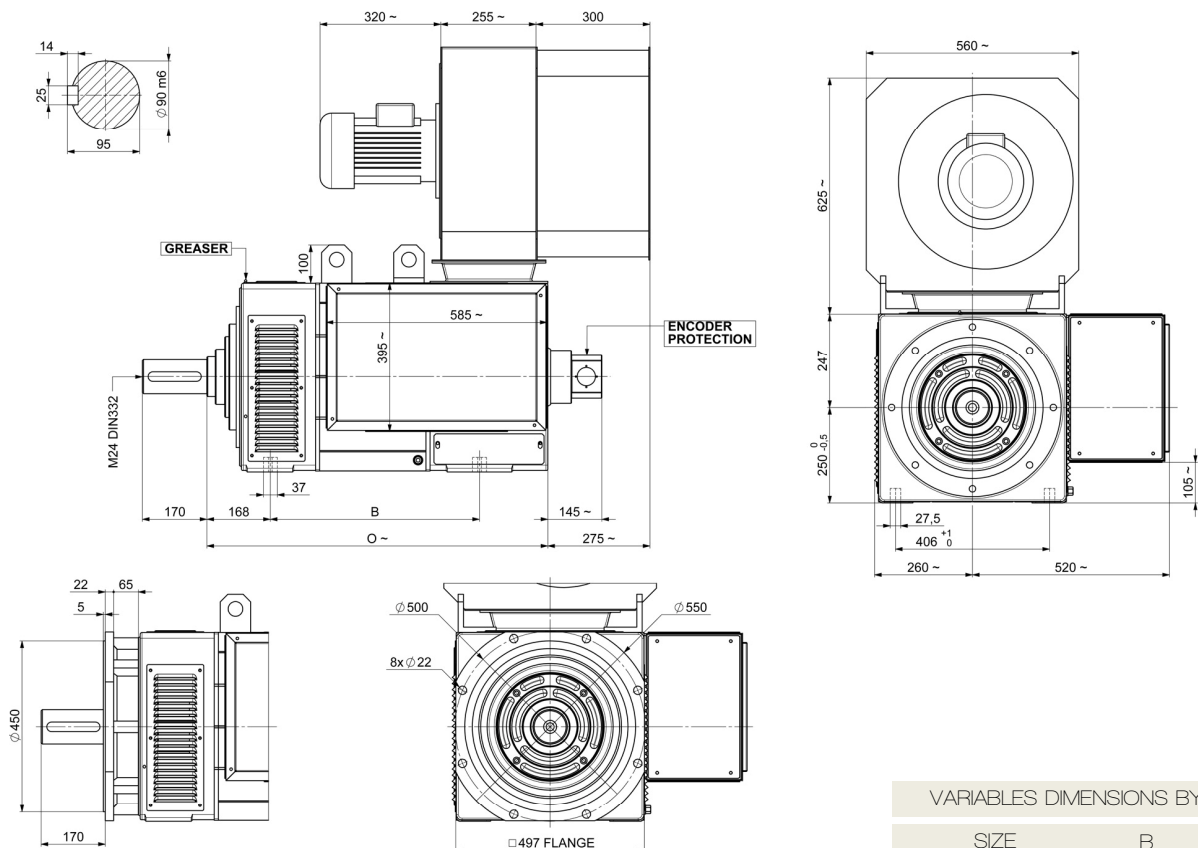

VARIABLES DIMENSIONS BY SIZE		
SIZE	B	O
250K.30	571	920
250K.40	671	1020
250K.50	771	1120
250K.60	871	1220
250K.70	971	1320

unit [mm]

400V SUPPLY STANDARD WINDING CODES

Speed Frequency	Type	Rotor Inertia	Max. absolute torque at 400V	Rated torque	Rated power	Rated voltage	Rated current	power factor	Efficiency
rpm Hz		Kgm ²	Nm	Nm	kW	V	A	cosφ	η
700 35Hz	250K.30	1,9	2.900	1.680	123	395	210	0,91	0,94
	250K.40	2,5	3.800	2.200	161	375	285	0,92	0,95
	250K.50	3,1	4.800	2.730	200	355	375	0,91	0,95
	250K.60	3,8	5.700	3.200	235	385	400	0,92	0,96
	250K.70	4,4	6.700	3.700	271	370	480	0,92	0,96
1400 70Hz	250K.30	1,9	2.900	1.670	245	385	420	0,91	0,96
	250K.40	2,5	3.800	2.180	320	370	565	0,92	0,97
	250K.50	3,1	4.800	2.660	390	375	675	0,92	0,97
	250K.60	3,8	5.700	3.100	455	380	775	0,92	0,97
	250K.70	4,4	6.700	3.550	520	395	840	0,93	0,97
2000 100Hz	250K.30	1,9	2.900	1.600	335	390	555	0,92	0,97
	250K.40	2,5	3.800	2.150	450	390	745	0,92	0,97
	250K.50	3,1	4.800	2.580	540	365	950	0,93	0,97
	250K.60	3,8	5.700	3.000	628	390	1.035	0,93	0,97
	250K.70	4,4	6.700	3.400	712	395	1.150	0,93	0,97

All data outputs are referred to power converter clocking frequency (PWM) >4kHz

Other windings on request

POWERTECH SY6 TETRAVEC 315L

GENERAL SPEED IE4 SYNCHRONOUS MOTORS

OVERVIEW

Rev. 1.1

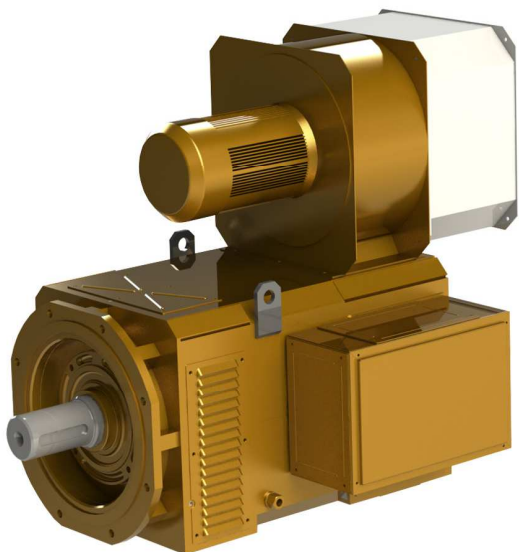

IP PROTECTION	IP23
POLES	2p=6
THERMAL PROTECTION TYPE	PT100 (and other on request)
BALANCING, VIBRATION GRADE (EN 60034-14 / VDE 0530 part 14)	A (B on request)
INSULATION CLASS	F
COOLING METHOD	IC06 (with filter on request)
STANDARD FAN DETAILS	3x230/400Vac 50Hz 19,6/11,3A
Amb. Cond.	0 + 40°C (32 + 104°F) 1000m ASL
TRANSDUCER	ENCODER OR RESOLVER (on request)
MOUNTING FORM	B3, B35, or other on request
BRAKE	up to 2500 Nm (on request)
DE BEARING	BALL (ROLLER on request)
NDE BEARING	BALL (INSULATED)
MAX ABSOLUTE SPEED	1800 r.p.m.
PAINTING SYSTEM	NITRO, POLYURETHANIC, C5M, on request

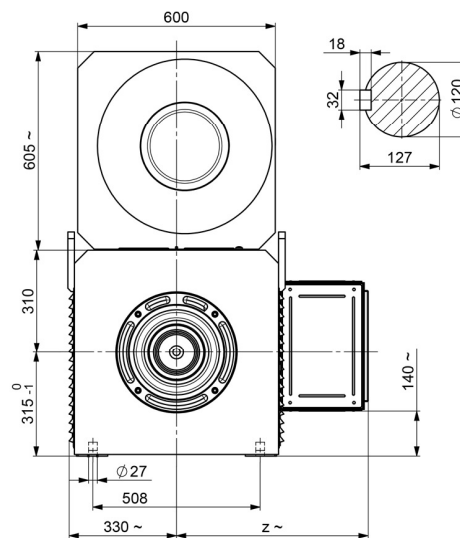
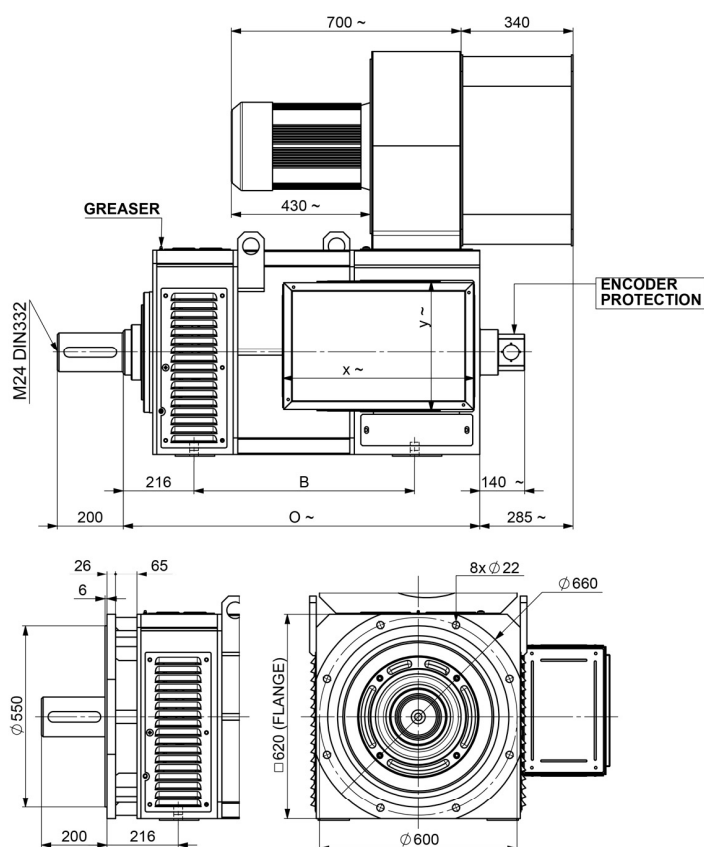

TERMINAL BOX DIMENSIONS			
MOTOR CURRENT	x	x	z
TILL 1500 A	585	400	585
OVER 1500 A	645	534	585

unit [mm]

VARIABLES DIMENSIONS BY SIZE		
SIZE	B	O
315L.40	730	1150
315L.50	830	1250
315L.60	930	1350
315L.70	1030	1450
315L.80	1130	1550

400V SUPPLY STANDARD WINDING CODES

Speed Frequency	Type	Rotor Inertia	Max. absolute torque at 400V	Rated torque	Rated power	Rated voltage	Rated current	power factor	Efficiency
rpm Hz		Kgm ²	Nm	Nm	kW	V	A	cosφ	η
500 25Hz	315L.40	6,6	6.200	4.050	212	380	385	0,89	0,95
	315L.50	8,2	7.600	5.060	265	370	495	0,88	0,95
	315L.60	9,9	9.500	6.000	315	375	570	0,89	0,95
	315L.70	11,5	11.000	6.880	360	365	665	0,90	0,96
	315L.80	13,2	12.500	7.830	410	380	730	0,89	0,96
1000 50Hz	315L.40	6,6	6.200	3.920	410	375	740	0,88	0,97
	315L.50	8,2	7.600	4.840	507	385	880	0,89	0,97
	315L.60	9,9	9.500	5.780	605	370	1.090	0,89	0,97
	315L.70	11,5	11.000	6.700	702	365	1.285	0,89	0,97
	315L.80	13,2	12.500	7.650	800	370	1.435	0,90	0,97
1500 75Hz	315L.40	6,6	6.200	3.820	600	370	1.085	0,89	0,97
	315L.50	8,2	7.600	4.840	760	380	1.330	0,89	0,97
	315L.60	9,9	9.500	5.730	900	365	1.630	0,90	0,97
	315L.70	11,5	11.000	6.580	1.030	365	1.850	0,90	0,97
	315L.80	13,2	12.500	7.500	1.180	365	2.125	0,90	0,98

All data outputs are referred to power converter clocking frequency (PWM) >4kHz

Other windings on request

POWERTECH SY4 FLUID 132

GENERAL SPEED IE4 SYNCHRONOUS MOTORS

OVERVIEW

Rev. 1.0

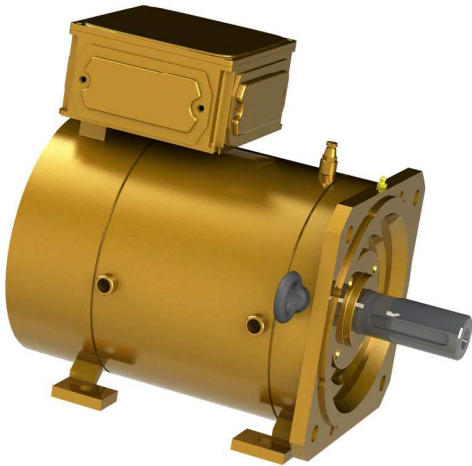

IP PROTECTION	IP54 (IP55 on request)
POLES	2p=4
THERMAL PROTECTION TYPE	PT100 (and other on request)
BALANCING, VIBRATION GRADE (EN 60034-14 / VDE 0530 part 14)	A (B on request)
INSULATION CLASS	F
COOLING METHOD	LIQUID (flow rate by size) 10 + 25°C (50 + 77 °F) + GLYCOL 20%
Amb. Cond.	0 + 40°C (32 + 104°F) 1000m ASL
TRANSDUCER	ENCODER OR RESOLVER (on request)
MOUNTING FORM	B3, B35, or other on request
BRAKE	up to 300 Nm (on request)
DE BEARING	BALL (ROLLER request)
NDE BEARING	BALL
MAX ABSOLUTE SPEED	2700 r.p.m.
PAINTING SYSTEM	NITRO, POLYURETHANIC, C5M, on request

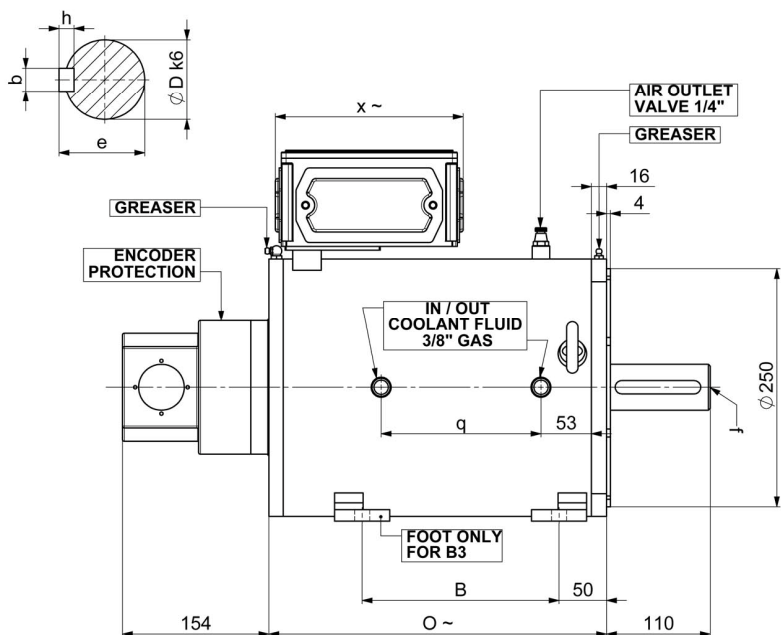
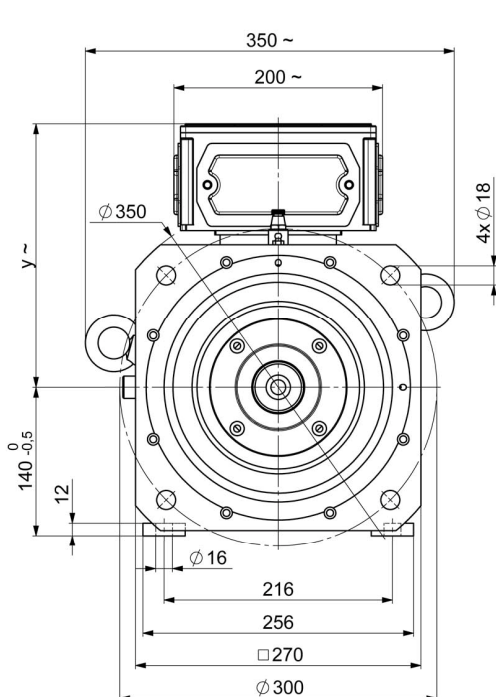

SHAFT AND KEYWAY			
D	b x h	e	f
48	14X9	51,5	M16

unit [mm]

VARIABLES DIMENSIONS BY SIZE			
SIZE	B	O	q
132.17	252	400	213
132.21	287	435	248
132.28	357	505	318
132.35	427	575	388

400V SUPPLY STANDARD WINDING CODES

Speed Frequency	Type	Rotor Inertia	Max. absolute torque at 400V	Rated torque	Rated power	Rated voltage	Rated current	power factor	Efficiency	Liquid flow rate
rpm Hz		Kgm ²	Nm	Nm	kW	V	A	cos φ	η	L/1'
800 26,7Hz	132.17	0,07	450	175	14,6	335	30	0,96	0,87	9,5
	132.21	0,08	530	205	17,2	365	32	0,97	0,88	10
	132.28	0,11	700	280	23,5	360	42	0,99	0,90	11
	132.35	0,14	900	340	28,5	360	52	0,98	0,90	12
1500 50Hz	132.17	0,07	450	165	26,0	365	46	0,98	0,92	9,5
	132.21	0,08	530	195	30,7	345	57	0,97	0,93	10
	132.28	0,11	700	265	41,7	345	77	0,98	0,93	11
	132.35	0,14	900	330	52,0	360	91	0,98	0,94	12
2250 75Hz	132.17	0,07	450	160	37,8	350	68	0,98	0,94	9,5
	132.21	0,08	530	190	45,0	345	81	0,99	0,94	10
	132.28	0,11	700	260	61,1	340	113	0,98	0,95	11
	132.35	0,14	900	325	76,5	370	128	0,98	0,95	12

All data outputs are referred to power converter clocking frequency (PWM) >4kHz

Other windings on request

POWER DERATING BY INLET LIQUID TEMPERATURE

30°C (86°F) -3,5%

35°C (95°F) -6%

40°C (104°F) -10%

45°C (113°F) -12%

POWERTECH SY4 FLUID 160

GENERAL SPEED IE4 SYNCHRONOUS MOTORS

OVERVIEW

Rev. 1.1

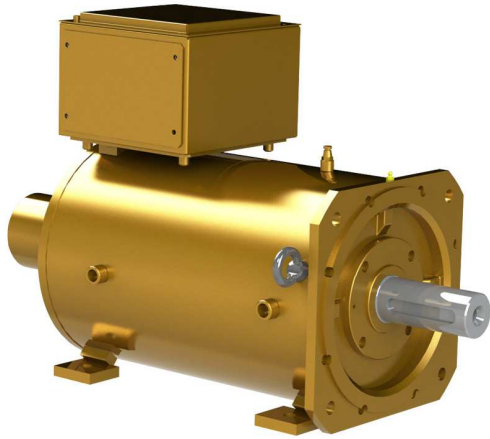

IP PROTECTION	IP54 (IP55 on request)
POLES	2p=4
THERMAL PROTECTION TYPE	PT100 (and other on request)
BALANCING, VIBRATION GRADE (EN 60034-14 / VDE 0530 part 14)	A (B on request)
INSULATION CLASS	F
COOLING METHOD	LIQUID (flow rate by size) 10 + 25°C (50 + 77 °F) + GLYCOL 20%
Amb. Cond.	0 + 40°C (32 + 104°F) 1000m ASL
TRANSDUCER	ENCODER OR RESOLVER (on request)
MOUNTING FORM	B3, B35, or other on request
BRAKE	up to 400 Nm (on request)
DE BEARING	BALL (ROLLER request)
NDE BEARING	BALL (insulated on request)
MAX ABSOLUTE SPEED	2700 r.p.m.
PAINTING SYSTEM	NITRO, POLYURETHANIC, C5M, on request

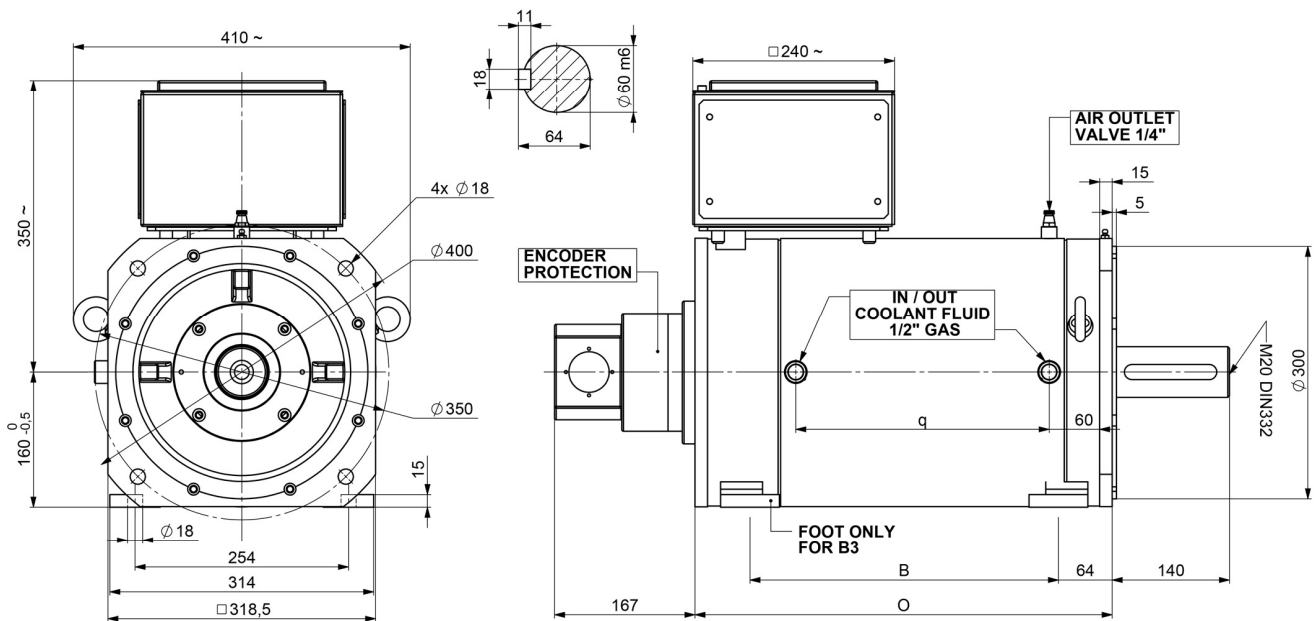

VARIABLES DIMENSIONS BY SIZE

SIZE	B	O	q
160.25	387	520	321,5
160.30	437	570	371,5
160.35	487	620	421,5
160.40	537	670	471,5
160.45	587	720	521,5

unit [mm]

400V SUPPLY STANDARD WINDING CODES

Speed Frequency	Type	Rotor Inertia	Max. absolute torque at 400V	Rated torque	Rated power	Rated voltage	Rated current	power factor	Efficiency	Liquid flow rate
rpm Hz		Kgm ²	Nm	Nm	kW	V	A	cosφ	η	L/1'
800 26,7Hz	160.25	0,20	550	360	30,1	370	57	0,90	0,91	15
	160.30	0,24	700	430	36,0	370	68	0,91	0,92	16
	160.35	0,28	830	475	40,0	350	77	0,92	0,93	17
	160.40	0,32	950	530	44,4	345	88	0,91	0,93	18
	160.45	0,35	1.100	580	48,6	355	94	0,90	0,93	19
1500 50Hz	160.25	0,20	550	340	53,2	365	100	0,89	0,94	16
	160.30	0,24	700	395	62,0	355	117	0,91	0,95	17
	160.35	0,28	830	460	72,3	365	131	0,92	0,95	18
	160.40	0,32	950	510	80,1	370	145	0,90	0,95	19
	160.45	0,35	1.100	565	89,0	355	167	0,91	0,96	19
2250 75Hz	160.25	0,20	550	330	78,0	340	152	0,91	0,95	15
	160.30	0,24	700	390	92,0	350	174	0,91	0,96	16
	160.35	0,28	830	450	106	340	208	0,90	0,96	17
	160.40	0,32	950	400	118	385	200	0,91	0,96	18
	160.45	0,35	1.100	550	130	355	243	0,91	0,96	19

All data outputs are referred to power converter clocking frequency (PWM) >4kHz

Other windings on request

POWER DERATING BY INLET LIQUID TEMPERATURE

30°C (86°F) -3,5%

35°C (95°F) -6%

40°C (104°F) -10%

45°C (113°F) -12%

POWERTECH SY6 FLUID 200

GENERAL SPEED IE4 SYNCHRONOUS MOTORS

OVERVIEW

Rev. 1.1

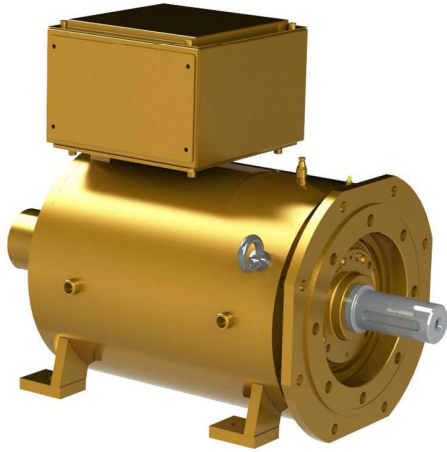

IP PROTECTION	IP54 (IP55 on request)
POLES	2p=6
THERMAL PROTECTION TYPE	PT100 (and other on request)
BALANCING, VIBRATION GRADE (EN 60034-14 / VDE 0530 part 14)	A (B on request)
INSULATION CLASS	F
COOLING METHOD	LIQUID (flow rate by size) 10 + 25°C (50 + 77 °F) + GLYCOL 20%
Amb. Cond.	0 + 40°C (32 + 104°F) 1000m ASL
TRANSDUCER	ENCODER OR RESOLVER (on request)
MOUNTING FORM	B3, B35, or other on request
BRAKE	up to 600 Nm (on request)
DE BEARING	BALL (ROLLER on request)
NDE BEARING	BALL (insulated on request)
MAX ABSOLUTE SPEED	2500 r.p.m.
PAINTING SYSTEM	NITRO, POLYURETHANIC, C5M, on request

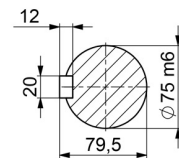
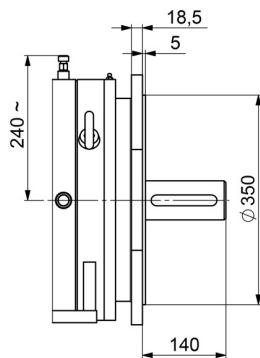
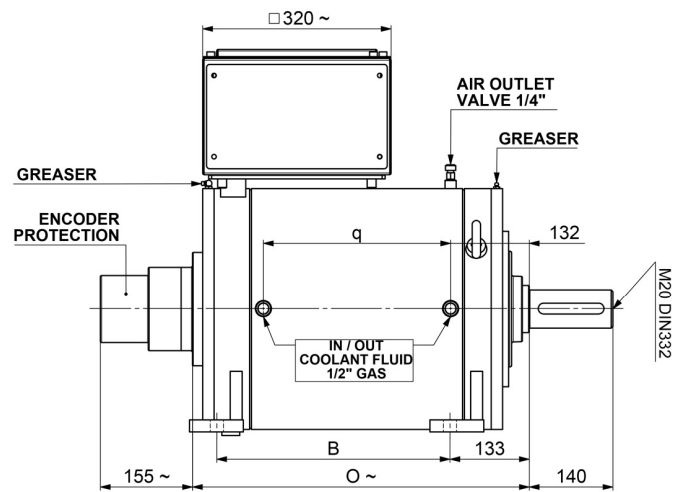
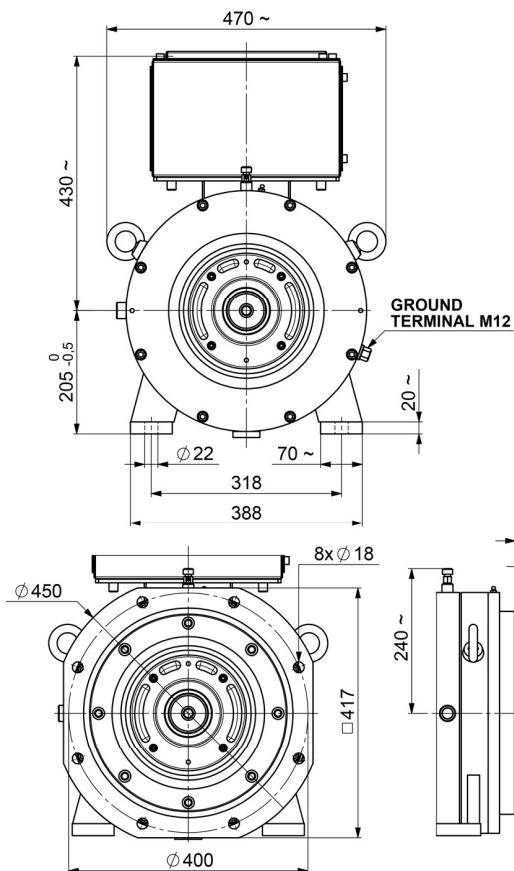

VARIABLES DIMENSIONS BY SIZE

SIZE	B	O	q
200.30	450	625	373
200.35	500	675	423
200.40	550	725	473
200.50	650	825	573
200.55	700	875	623

unit [mm]

400V SUPPLY STANDARD WINDING CODES

Speed Frequency	Type	Rotor Inertia	Max. absolute torque at 400V	Rated torque	Rated power	Rated voltage	Rated current	power factor	Efficiency	Liquid flow rate
rpm Hz		Kgm ²	Nm	Nm	kW	V	A	cosφ	η	L/1'
700 35Hz	200.30	0,68	1.500	750	55	390	93	0,94	0,93	18
	200.35	0,81	1.800	875	64	385	112	0,92	0,94	19
	200.40	0,93	2.100	990	72	360	133	0,92	0,94	20
	200.50	1,15	2.700	1.200	88	350	164	0,94	0,94	22
	200.55	1,27	3.000	1.310	96	345	178	0,95	0,95	22
1400 70Hz	200.30	0,68	1.500	700	103	375	176	0,94	0,96	18
	200.35	0,81	1.800	810	118	350	218	0,93	0,96	19
	200.40	0,93	2.100	920	135	350	248	0,93	0,96	20
	200.50	1,15	2.700	1.160	170	375	290	0,94	0,96	22
	200.55	1,58	3.000	1.270	186	345	345	0,94	0,96	23
2000 100Hz	200.30	0,68	1.500	650	136	370	234	0,94	0,96	18
	200.35	0,81	1.800	755	158	370	272	0,94	0,97	19
	200.40	0,93	2.100	860	180	350	325	0,95	0,97	20
	200.50	1,15	2.700	1.080	226	350	406	0,95	0,97	22
	200.55	1,58	3.000	1.190	250	385	405	0,96	0,97	23

All data outputs are referred to power converter clocking frequency (PWM) >4kHz

Other windings on request

POWER DERATING BY INLET LIQUID TEMPERATURE

30°C (86°F) -3,5%

35°C (95°F) -6%

40°C (104°F) -10%

45°C (113°F) -12%

POWERTECH SY6 FLUID 250

GENERAL SPEED IE4 SYNCHRONOUS MOTORS

OVERVIEW

Rev. 1.1

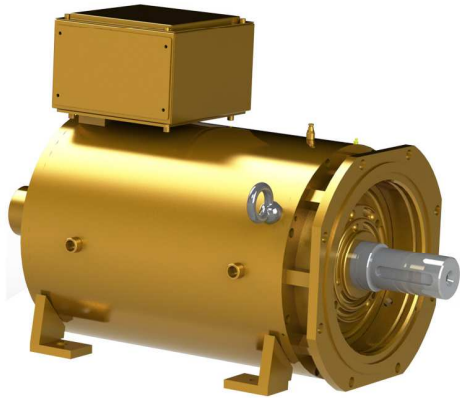

IP PROTECTION	IP54 (IP55 on request)
POLES	2p=6
THERMAL PROTECTION TYPE	PT100 (and other on request)
BALANCING, VIBRATION GRADE (EN 60034-14 / VDE 0530 part 14)	A (B on request)
INSULATION CLASS	F
COOLING METHOD	LIQUID (flow rate by size) 10 + 25°C (50 + 77 °F) + GLYCOL 20%
Amb. Cond.	0 + 40°C (32 + 104°F) 1000m ASL
TRANSDUCER	ENCODER OR RESOLVER (on request)
MOUNTING FORM	B3, B35, or other on request
BRAKE	up to 2400 Nm (on request)
DE BEARING	BALL (ROLLER request)
NDE BEARING	BALL (insulated on request)
MAX ABSOLUTE SPEED	2300 r.p.m.
PAINTING SYSTEM	NITRO, POLYURETHANIC, C5M, on request

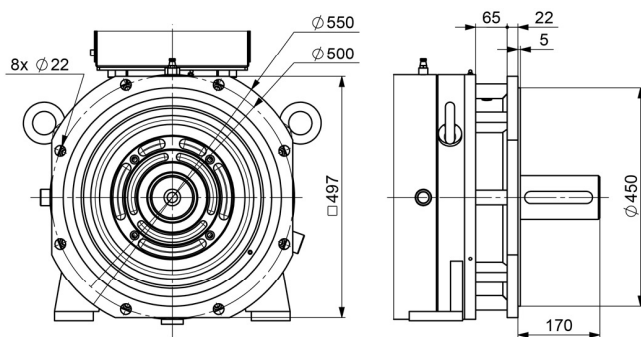
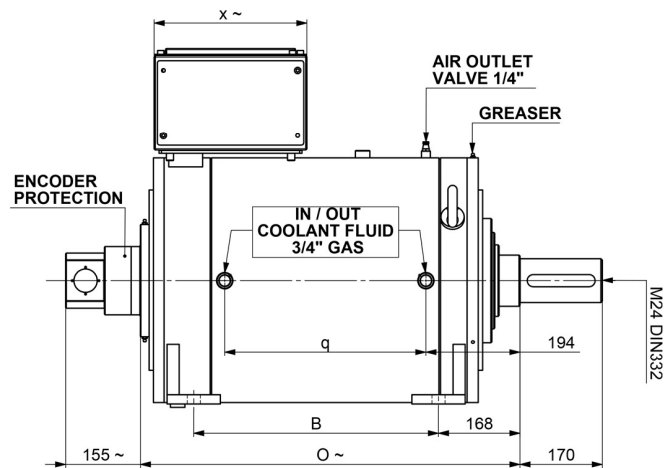
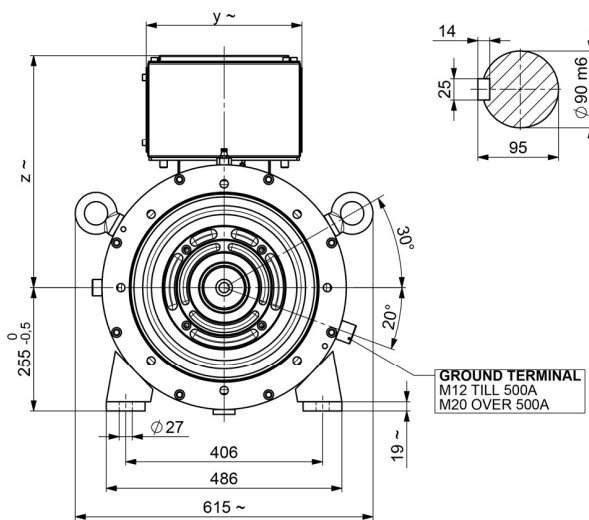

TERMINAL BOX DIMENSIONS			
MOTOR CURRENT	x	x	z
TILL 500 A	315	320	480
OVER 500 A	585	395	535

unit [mm]

VARIABLES DIMENSIONS BY SIZE			
SIZE	B	O	q
250.30	525	805	435
250.40	625	905	535
250.50	725	1005	635
250.60	825	1105	735
250.70	925	1205	835

400V SUPPLY STANDARD WINDING CODES

Speed Frequency	Type	Rotor Inertia	Max. absolute torque at 400V	Rated torque	Rated power	Rated voltage	Rated current	power factor	Efficiency	Liquid flow rate
rpm Hz		Kgm ²	Nm	Nm	kW	V	A	cosφ	η	L/1'
700 35Hz	250.30	1,9	2.900	1.500	110	385	190	0,91	0,95	26
	250.40	2,5	3.800	2.000	147	370	260	0,93	0,95	28
	250.50	3,1	4.800	2.480	182	345	340	0,94	0,96	30
	250.60	3,8	5.700	2.950	216	380	370	0,92	0,96	32
	250.70	4,4	6.700	3.410	250	360	445	0,94	0,96	34
1400 70Hz	250.30	1,9	2.900	1.450	212	380	365	0,92	0,96	26
	250.40	2,5	3.800	1.910	280	365	495	0,93	0,97	28
	250.50	3,1	4.800	2.390	350	370	610	0,92	0,97	30
	250.60	3,8	5.700	2.850	418	375	715	0,93	0,97	32
	250.70	4,4	6.700	3.300	484	395	780	0,94	0,97	34
2000 100Hz	250.30	1,9	2.900	1.350	282	380	470	0,94	0,97	26
	250.40	2,5	3.800	1.800	377	385	625	0,93	0,97	28
	250.50	3,1	4.800	2.240	470	360	830	0,94	0,97	30
	250.60	3,8	5.700	2.650	555	385	915	0,94	0,97	32
	250.70	4,4	6.700	3.100	650	385	1.050	0,96	0,97	34

All data outputs are referred to power converter clocking frequency (PWM) >4kHz

Other windings on request

POWER DERATING BY INLET LIQUID TEMPERATURE

30°C (86°F) -3,5%

35°C (95°F) -6%

40°C (104°F) -10%

45°C (113°F) -12%

POWERTECH SY6 FLUID 315

GENERAL SPEED IE4 SYNCHRONOUS MOTORS

OVERVIEW

Rev. 1.1

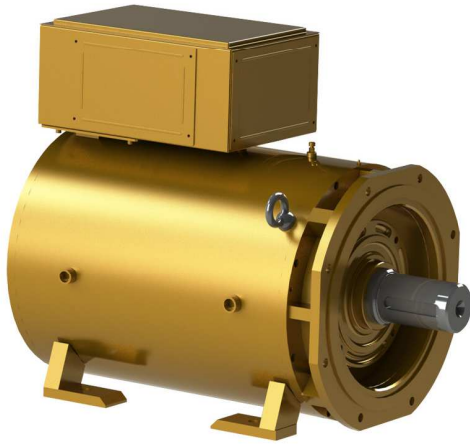

IP PROTECTION	IP54 (IP55 on request)
POLES	2p=6
THERMAL PROTECTION TYPE	PT100 (and other on request)
BALANCING, VIBRATION GRADE (EN 60034-14 / VDE 0530 part 14)	A (B on request)
INSULATION CLASS	F
COOLING METHOD	LIQUID (flow rate by size) 10 + 25°C (50 + 77 °F) + GLYCOL 20%
Amb. Cond.	0 + 40°C (32 + 104°F) 1000m ASL
TRANSDUCER	ENCODER OR RESOLVER (on request)
MOUNTING FORM	B3, B35, or other on request
BRAKE	up to 2500 Nm (on request)
DE BEARING	BALL (ROLLER request)
NDE BEARING	BALL (INSULATED)
MAX ABSOLUTE SPEED	1800 r.p.m.
PAINTING SYSTEM	NITRO, POLYURETHANIC, C5M, on request

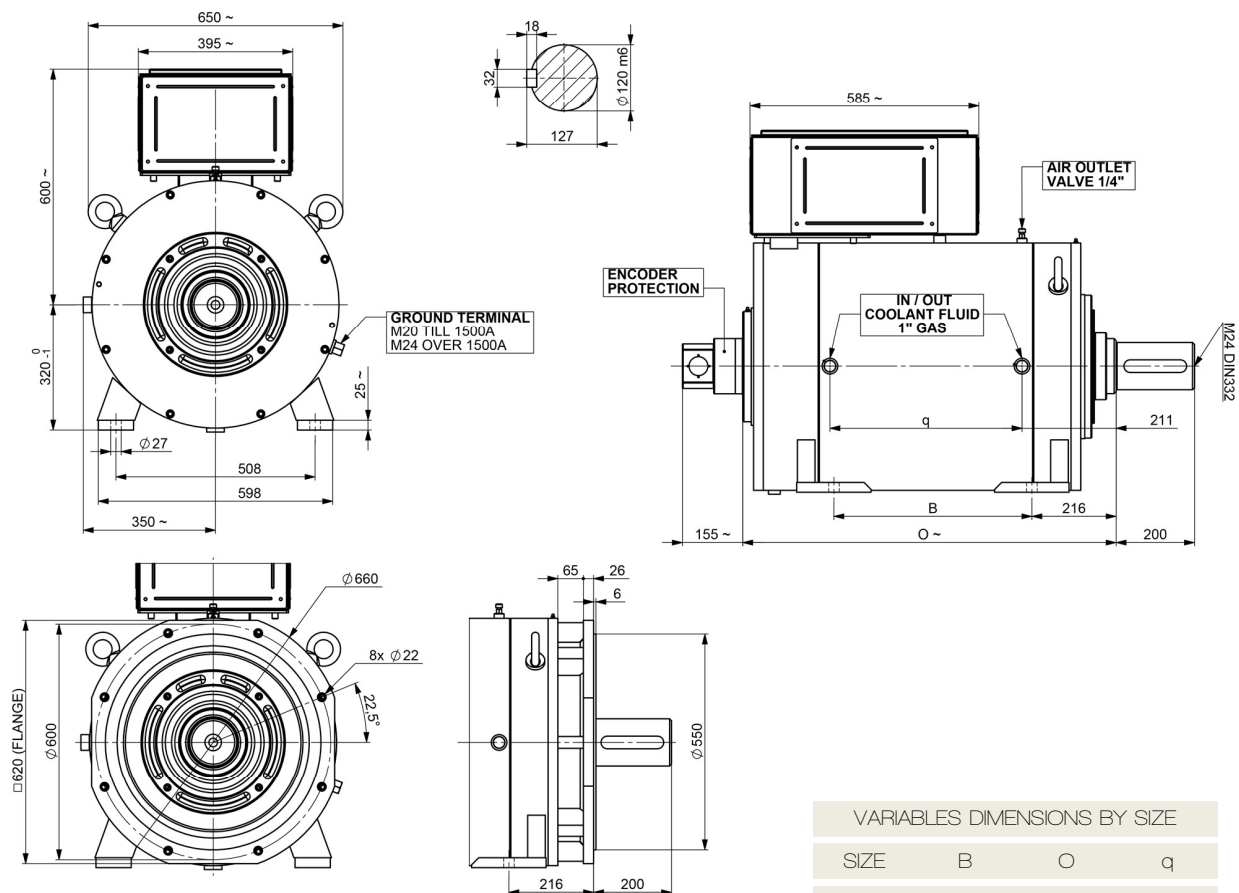

VARIABLES DIMENSIONS BY SIZE			
SIZE	B	O	q
315.40	565	1015	550
315.50	665	1115	650
315.60	765	1215	750
315.70	865	1315	850
315.80	965	1415	950

unit [mm]

400V SUPPLY STANDARD WINDING CODES

Speed Frequency	Type	Rotor Inertia	Max. absolute torque at 400V	Rated torque	Rated power	Rated voltage	Rated current	power factor	Efficiency	Liquid flow rate
rpm Hz		Kgm ²	Nm	Nm	kW	V	A	cosφ	η	L/1'
500 25Hz	315.40	6,6	6.200	3.120	163	375	290	0,91	0,95	38
	315.50	8,2	7.600	3.880	203	365	370	0,91	0,96	40
	315.60	9,9	9.500	4.650	243	370	430	0,92	0,96	42
	315.70	11,5	11.000	5.450	285	360	518	0,92	0,96	44
	315.80	13,2	12.500	6.200	325	365	575	0,93	0,96	46
1000 50Hz	315.40	6,6	6.200	2.910	305	370	540	0,91	0,97	38
	315.50	8,2	7.600	3.630	380	380	645	0,92	0,97	40
	315.60	9,9	9.500	4.400	460	370	815	0,91	0,97	42
	315.70	11,5	11.000	5.140	538	360	975	0,91	0,97	44
	315.80	13,2	12.500	5.780	605	365	1.070	0,92	0,97	46
1500 75Hz	315.40	6,6	6.200	2.870	450	365	800	0,92	0,97	38
	315.50	8,2	7.600	3.560	560	375	955	0,93	0,97	40
	315.60	9,9	9.500	4.250	667	360	1.185	0,92	0,97	42
	315.70	11,5	11.000	4.900	770	370	1.335	0,92	0,97	44
	315.80	13,2	12.500	5.600	880	355	1.565	0,94	0,98	46

All data outputs are referred to power converter clocking frequency (PWM) >4kHz

Other windings on request

POWER DERATING BY INLET LIQUID TEMPERATURE

30°C (86°F) -3,5%

35°C (95°F) -6%

40°C (104°F) -10%

45°C (113°F) -12%

POWERTECH

OTHER AC PRODUCTION

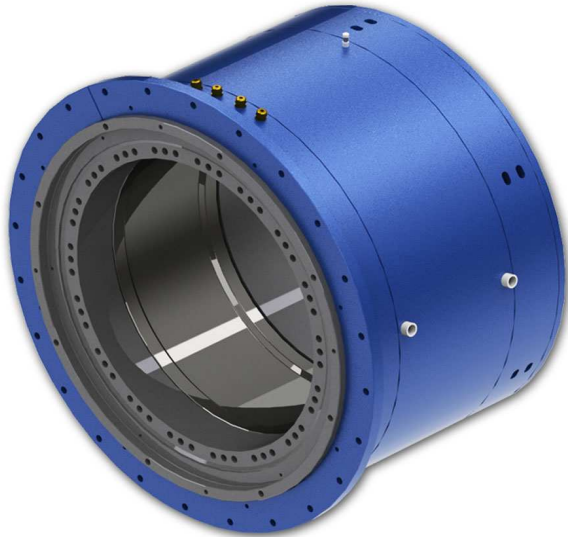

WIND GENERATOR

POWER RANGE

60kW	45-60 r.p.m.
100kW	38-45 r.p.m.
200kW	32-40 r.p.m.

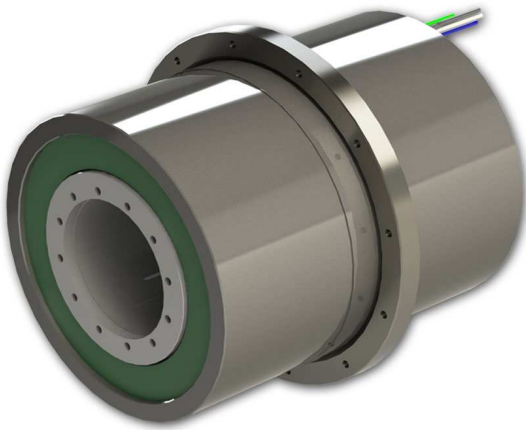

HOLLOW SHAFT

COMER's highly qualified staff is able to develop unusual applications, which involve motors with special mechanical characteristics, such as hollow-shaft motors or combined rotostator.

Based on the clients' needs, the technical office can evaluate a project, look for customized solutions able to fulfill the required electrical and mechanical specs., to bring about an efficient and high-quality Product, however keeping costs as reasonable as possible.



ROSTATOR

NOTICE

Data, technical features, drawings, images are only as estimates and can be modified at any time and without previous notice. COMER declines any responsibility for direct and indirect damage that can be caused by possible mistakes in this catalogue. COMER reserves the right to modify at any time and without previous notice the data, drawings, electric and/or mechanic details, dimensions and images. All information in this catalogue are COMER's property, therefore their reproduction (total and partial), copying and disclosure are prohibited, unless expressly authorized.

AVVISO

Dati, prestazioni, disegni e immagini sono indicativi e possono essere modificati in qualsiasi momento senza preavviso. COMER declina ogni responsabilità per danni diretti o indiretti causati da eventuali errori nel presente catalogo. COMER si riserva il diritto di modificare in qualsiasi momento e senza preavviso i dati, i disegni, caratteristiche elettriche e/o meccaniche, le dimensioni e le immagini. Tutte le informazioni contenute in questo catalogo sono di proprietà COMER, sono vietate riproduzione (totale e parziale), copia e divulgazione se non espressamente autorizzate.

AUSTREX
FOR YOUR BEST PERFORMANCE



Austrex Antriebstechnik GmbH.
Waxenbergerstraße 29
A-4181 Oberneukirchen
Tel.: +43 7212 20542
antriebstechnik@austrex.at
www.austrex.at

AUSTREX
FOR YOUR BEST PERFORMANCE



Austrex Antriebstechnik GmbH.
Waxenbergerstraße 29
A-4181 Oberneukirchen
Tel.: +43 7212 20542
antriebstechnik@austrex.at
www.austrex.at

May 2017

AUSTREX
FOR YOUR BEST PERFORMANCE



Austrex Antriebstechnik GmbH.
Waxenbergerstraße 29
A-4181 Oberneukirchen
Tel.: +43 7212 20542
antriebstechnik@austrex.at
www.austrex.at

May 2017